

Basic Blueprint Reading

...

Ric Costin

Basic Blueprint Reading

Basic Blueprint Reading

RIC COSTIN

OPEN OREGON EDUCATIONAL RESOURCES



Basic Blueprint Reading by Linn-Benton Community College is licensed under a [Creative Commons Attribution 4.0 International License](https://creativecommons.org/licenses/by/4.0/), except where otherwise noted.

Contents

<u>Introduction</u>	1
1. <u>Cover</u>	3
2. <u>The Language of Lines</u>	4
3. <u>Visualization</u>	15
4. <u>Technical Sketching</u>	38
5. <u>Scaling</u>	59
6. <u>Dimensioning</u>	65
7. <u>Auxiliary Views</u>	87
8. <u>Sectional Views</u>	96
9. <u>Machined Features</u>	110
10. <u>Print Interpretation</u>	126

Welcome to the Linn-Benton Welding Department's First edition to blueprint reading.

Being able to read and understand, as well as sketch, or even draw a blueprint, is important to the making of accurate parts and complete fabrications.

Blueprints are tools that communicate what needs to be built or made, what materials are needed and what specifications are required. They insure that a design is made with complete accuracy what meets the needs of the customer.

This book is an updated version of the originally authored publication by the Department of Engineering and Drafting Technology Department at Linn-Benton Community College, in Albany Oregon.

I. Cover

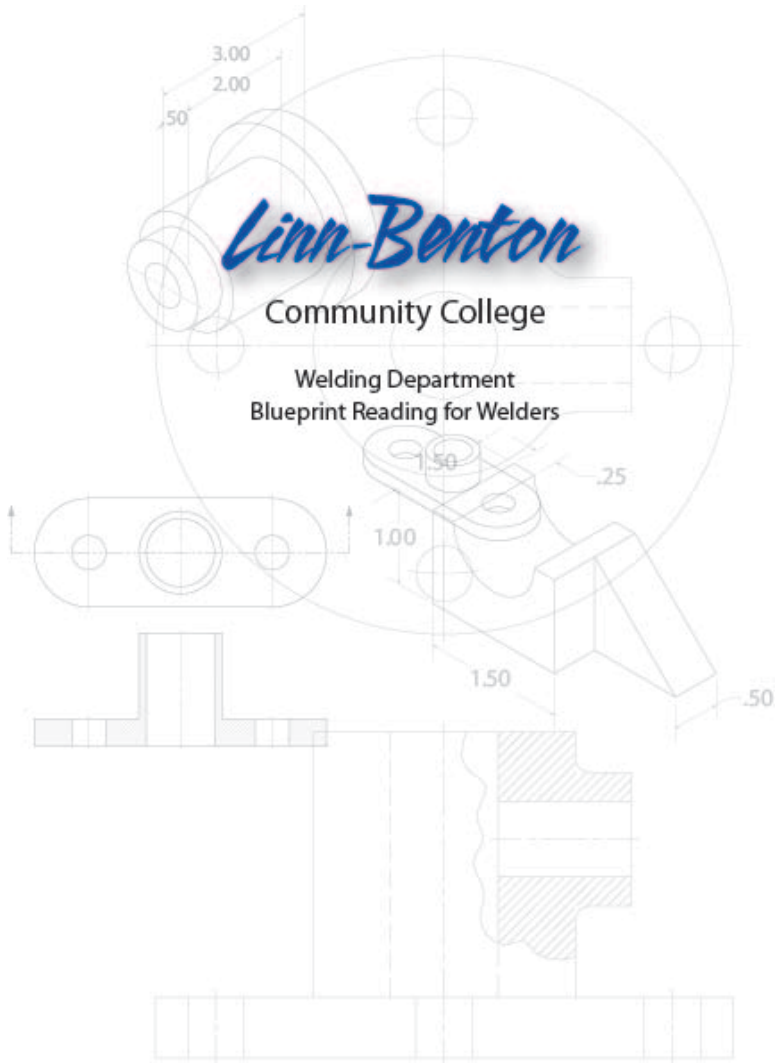

2. The Language of Lines

- OBJECTLINE
- HIDDEN LINE
- SECTION LINE
- CENTER LINE
- DIMENSION LINE
- EXTENSION LINE
- LEADER LINE
- CUTTING PLANE LINE
- BREAK LINES
- PHANTOM LINES
- BORDER LINE

You have heard the saying, “A picture is worth a thousand words”. This statement is particularly true in regards to technical drawings.

It would be almost impossible for an engineer, designer, or architect to describe in words the shape, size, and relationship of a complex object. Therefore, drawings have become the universal language used by engineers, designers, technicians, as well as craftsmen, to communicate the information necessary to build, assemble and service the products of industry.

It is important to remember, as you study Print Reading, that you are learning to communicate with the graphic language used by industry: Lines are part of that language.

Since technical drawings are made of lines, it is logical that the first step in learning to “read” a drawing is to learn the meaning of each kind of line. Generally, there are 11 basic types of lines. Each kind of line has a definite form and “weight”. Weight refers to line

thickness or width. When combined in a drawing, lines provide part of the Information needed to understand the print.

Being able to interpret a blueprint and accurately build objects is a needed skill to become successful in all trade crafts. It is a skill, like many others you will learn, and it will take time and practice to fully understand and become proficient.

Object Line

A **visible line**, or **object line** is a thick continuous line, used to outline the visible edges or contours of an object.

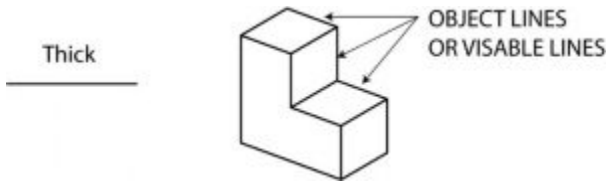

Hidden Line

A **hidden line**, also known as a **hidden object line** is a medium weight line, made of short dashes about 1/8" long with 1/16" gaps, to show edges, surfaces and corners which cannot be seen. Sometimes they are used to make a drawing easier to understand. Often they are omitted in an isometric view.

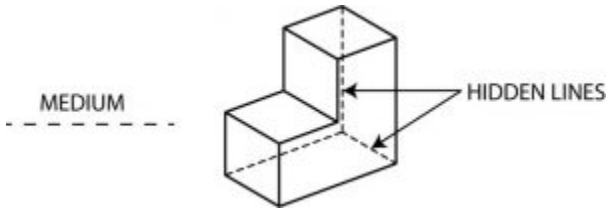

Section Line

Section lines are used to show the cut surfaces of an object in section views. They are fine, dark lines. Various types of section lines may indicate the type of material cut by the cutting plane line.

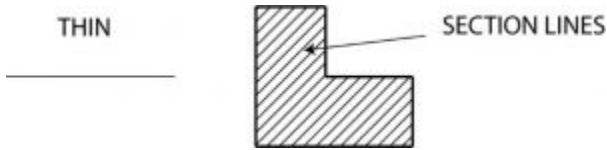

Center Line

Center lines are used to indicate the centers of holes, arcs, and symmetrical objects. They are very thin (size), long-short-long kinds of lines.

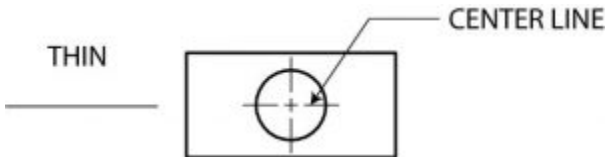

Dimension Line

Dimension lines are thin and are used to show the actual size of an object. There are arrowheads at both end that terminate at the extension lines.

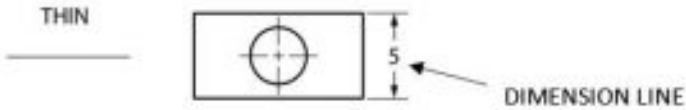

Extension Line

Extension lines are also thin lines, showing the limits of dimensions. Dimension line arrowheads touch extension lines.

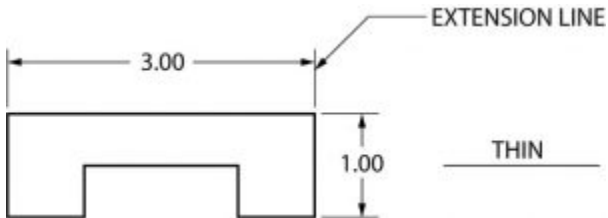

Leader Line

Leaders are more thin lines used to point to an area of a drawing requiring a note for explanation. They are preferably drawn at a 45° angles.

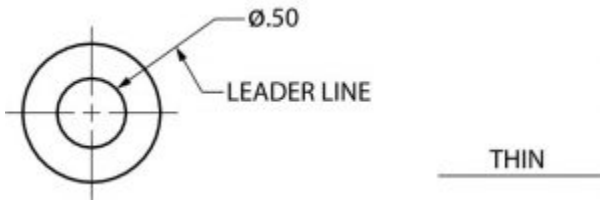

Cutting Plane Line

A cutting plane line (very heavy) helps to show the internal shape at a part or assembly by slicing through the object.

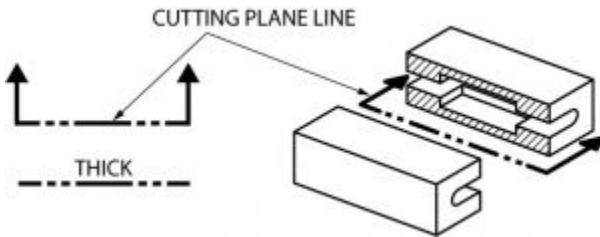

Break Line

There are three kinds of break lines used in drawings. They are used to remove, or 'break out' part of a drawing for clarity, and also to shorten objects which have the same shape throughout their length and may be too long to place on the drawing.

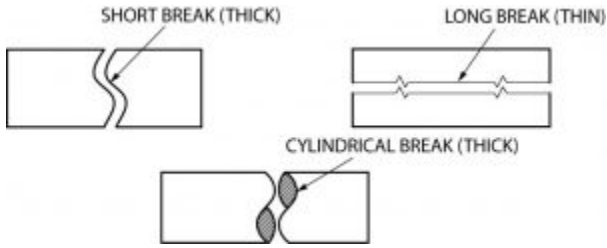

Short and long break lines are used for flat surfaces. Cylindrical are used on rods, dowels, etc.

Phantom Line

Phantom lines are long-short-short-long lines most often used to show the travel or movement of an object or a part in alternate positions. It can also be used to show adjacent objects or features.

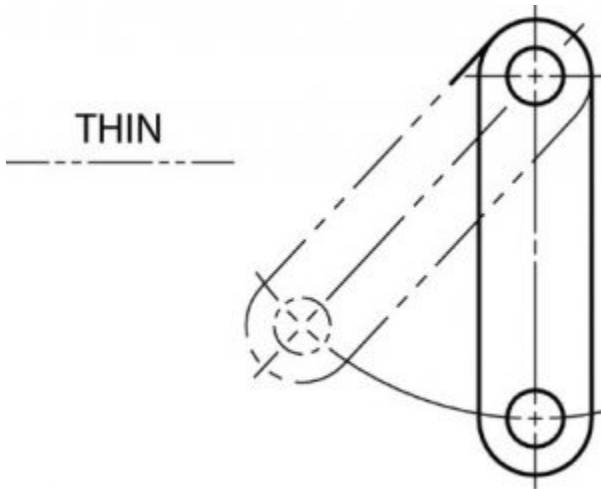

Border Line

Borderlines are very thick, continuous lines used to show the boundary of the drawing or to separate different objects drawn on one sheet. They are also used to separate the title block from the rest of the drawing.

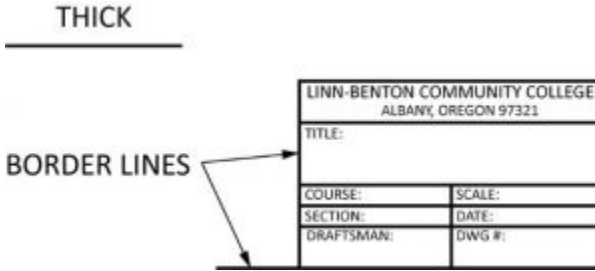

Quiz....

Directions: Name the types of lines shown below. Check your own answers

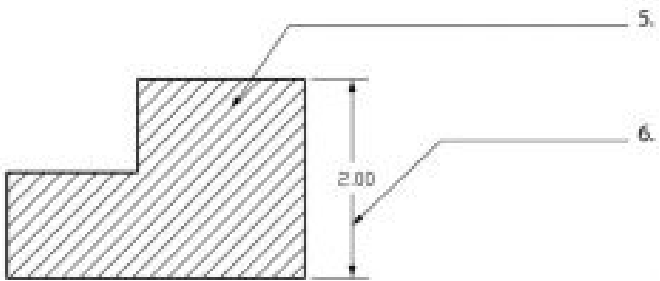
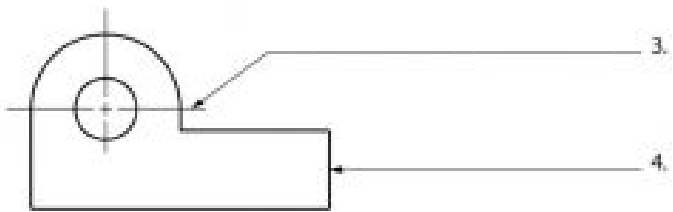
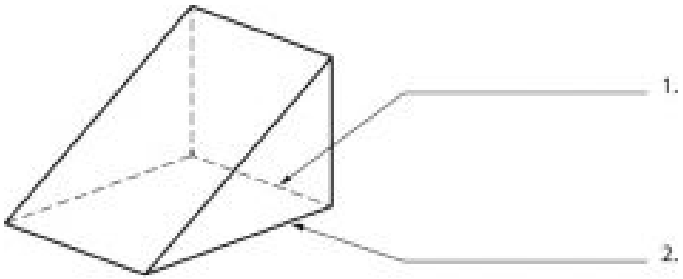

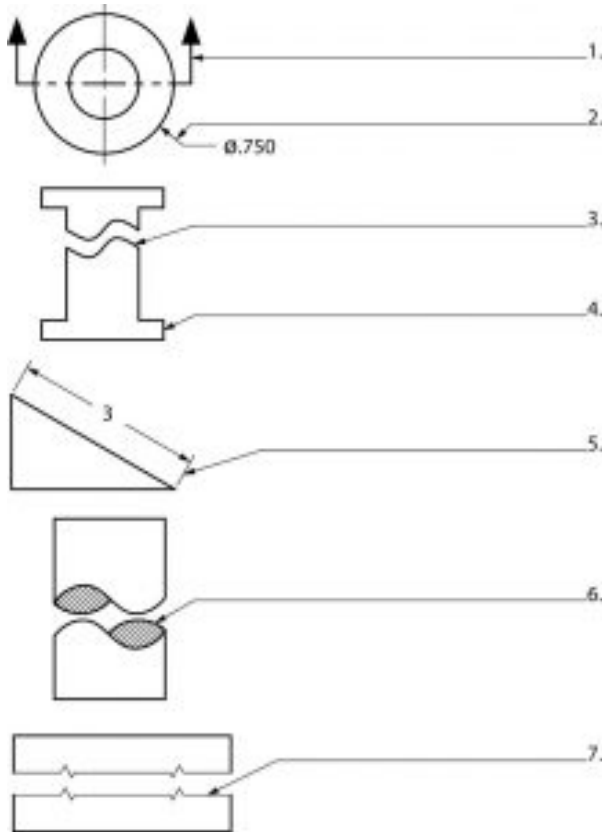

Directions: Draw and identify the lines needed to complete the figures as indicated.

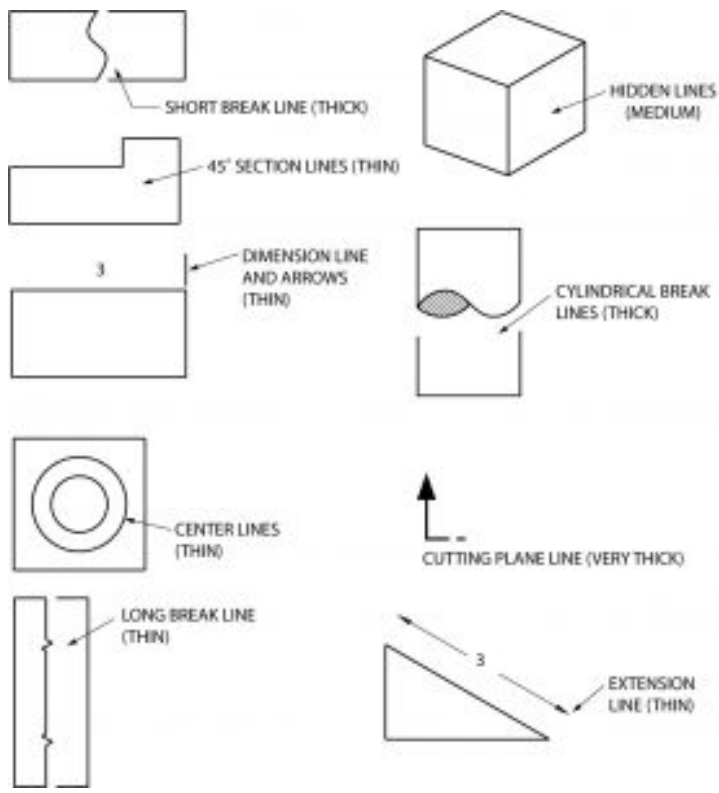

3. Visualization

Visualization

- PERSPECTIVE
- OBLIQUE DRAWING
- ISOMETRIC DRAWING
- ONE-VIEW DRAWING
- TWO-VIEW DRAWING
- ORTHOGRAPHIC PROJECTION
- HIDDEN SURFACES
- CURVED SURFACES
- INCLINED SURFACES

Now that you have learned about the kinds of lines found on prints, the next step is to develop your visualization abilities. The ability to "see" technical drawings; that is to "think in three dimensions," is the most important part of this course. Since most engineering and architectural prints utilize some form of orthographic projection (multi-view drawing), that type of drawing will be emphasized.

Before going into a study of orthographic projection, you should be able to recognize several other types of drawings. They are; 1. Perspective drawing, 2. Oblique drawing, and 3. Isometric drawing. As a group, they are called "pictorial drawings". They are found on prints and are easy to visualize, so let's look at their differences.

Perspective

Perspective is the most realistic form of drawing. Artists use one-

point perspective, two-point (shown here), and three point to create visual depth. Perspectives are used by architects and for industrial pictorials of plan layouts, machinery, and other subjects where realism is required. Objects drawn in perspective grow smaller as they recede into the horizon.

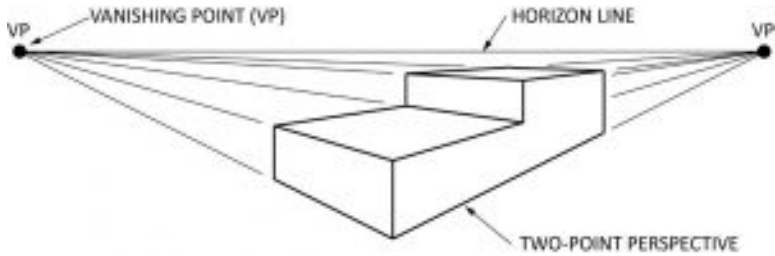

Oblique

Oblique drawings are drawn with one plane (front) of the object parallel to the drawing surface. The side, or other visible part of the object is generally drawn at 30° or 45° . Note that only the side is on an angle. Many times these types of drawing are not drawn to scale. The receding lines are drawn at 45° or 30° and will be drawn at a different scale as the vertical and horizontal lines. This makes the drawing seem “out of shape”. This type of drawing is not used very often in industry.

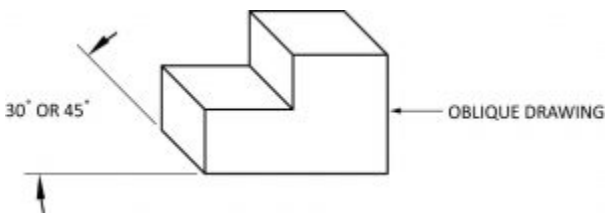

Isometric

Isometric drawings have less distortion than oblique drawings, and are used more frequently by industry for that reason. An isometric drawing has both visible surfaces drawn at 30° . These are the most used type of drawings in the piping industry and take a good deal of practice to fully understand how to draw. They best represent what is being built and what it will look like from the different sides with one drawing.

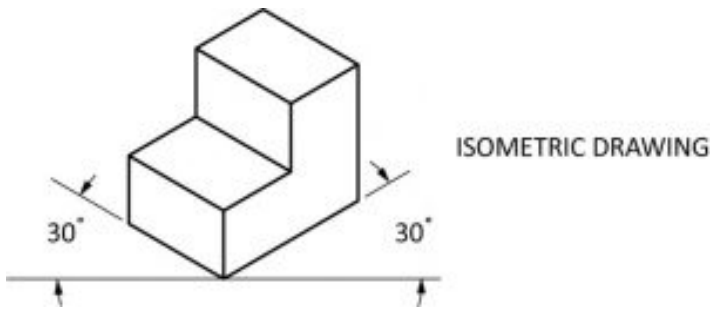

Directions: Name the types of drawings shown below. Check your own answers.

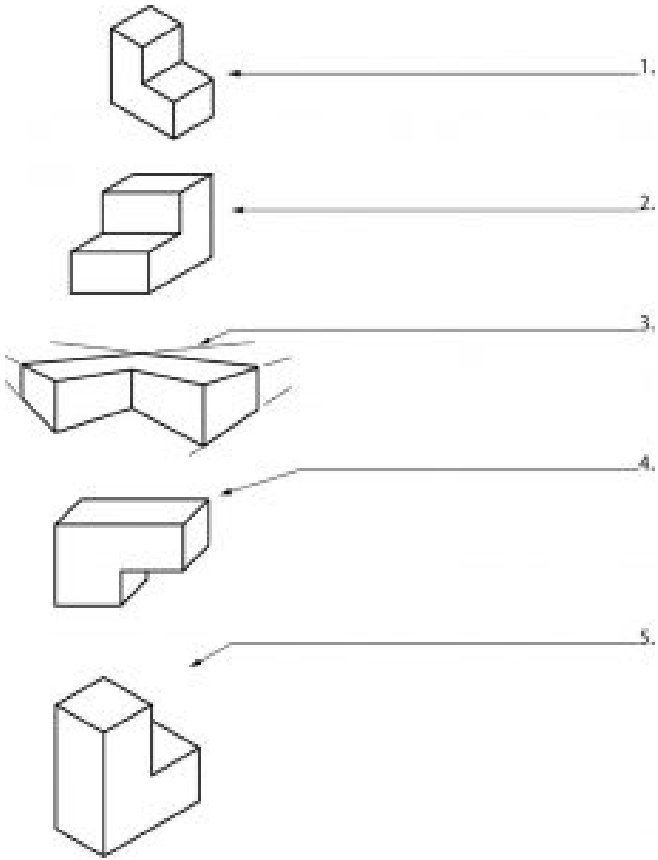

Single View

A single view of an object is sometimes all that is needed for a complete visual explanation. When dimensions, material, and other

information is Included, an object requiring only a single view is easy to understand.

Most one-view drawings are of flat objects, made from materials such as sheet metal and gasket stock. Spherical objects, such as a cannonball, would require only one view and a note indicating the material and diameter of the sphere.

The object shown in the one-view drawing below could be made of any appropriate material that might be specified. In appearance, it is much like the gasket used as part of the cooling system on many cars. All that would need to be noted is the material type and thickness required.

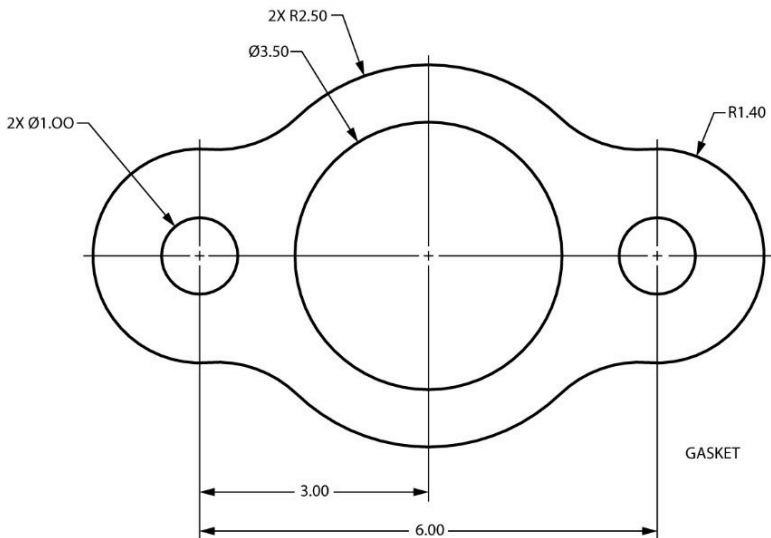

Two View

Sometimes “two-view” drawings are used on prints. Two views may be all that is needed to show the shape of an object. Objects that are cylindrical, such as a length of pipe, are usually shown on a print with two views. In such a case, two views is sufficient to explain the shape. Notice in the two-view drawing shown below that the length of the pipe is shown in one view, while the diameter is called out in the other. Without the view on the right, what might this shape be mistaken for? Square tube, channel...

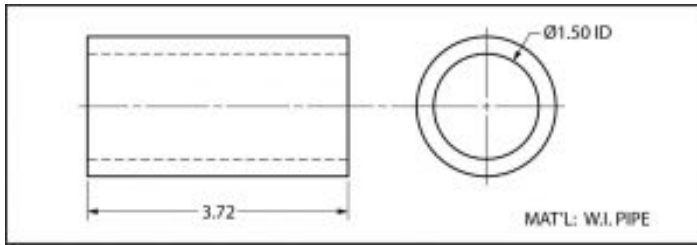

Orthographic Projection

Orthographic projection is a name given to drawings that usually have three views. Often, the three views selected are the top, front, and right side. It is possible, of course, to select other views such as the left side or bottom. Generally, though, it's the top, front and right side that are traditionally seen by the person reading prints.

Since most prints make use of the orthographic projection system, and because the top, front, right side views are most often used, it

is important that you have their order, or arrangement on the print fixed in your mind. To help you understand this system, think of a chalkboard eraser, a short length of 2" x 4" lumber, or a common brick. It looks like this:

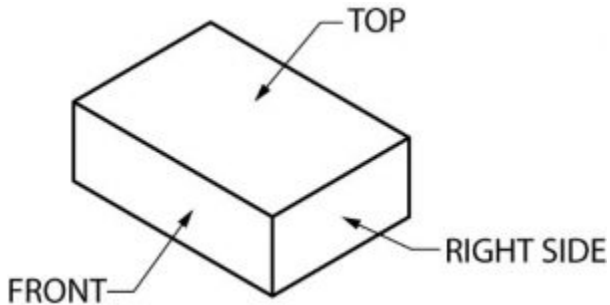

When seen on a print, using orthographic projection, it would appear like this.

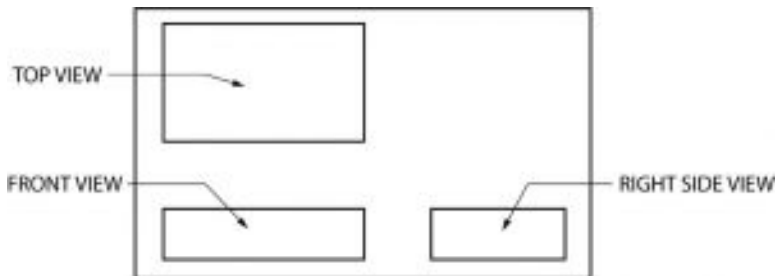

This system of orthographic projection may be difficult to understand or visualize at first, but you will grasp it with some

practice. Here's a basic example of how it works, using a simple object.

The Object:

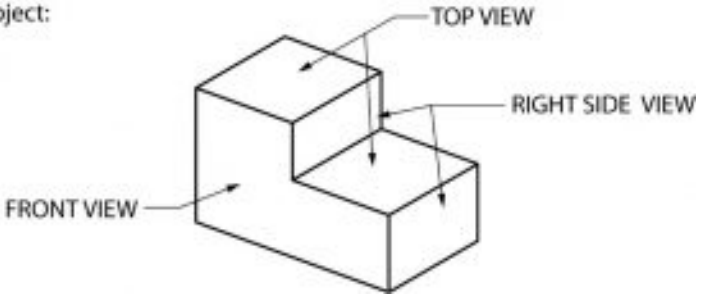

Orthographic projection does not show depth, so the object shown above will appear flat. With practice, however, you will learn to scan the three views and “read” depth into them. Remember that the location of the top, front and right side views does not change. The projection lines between the orthographic views below show the height, width, and depth relationship that exists between each view and the other two views.

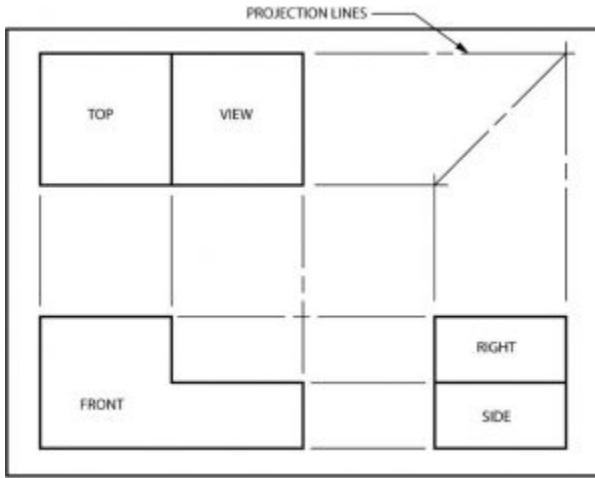

In case you did not understand the three-view on the last page, let's take another look at the same thing. This time numbers will be used for identification for the surfaces.

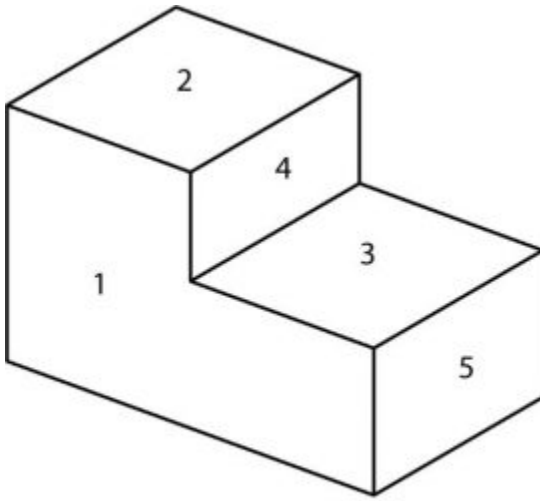

Using orthographic projection, the object with the surfaces numbered appears like this:

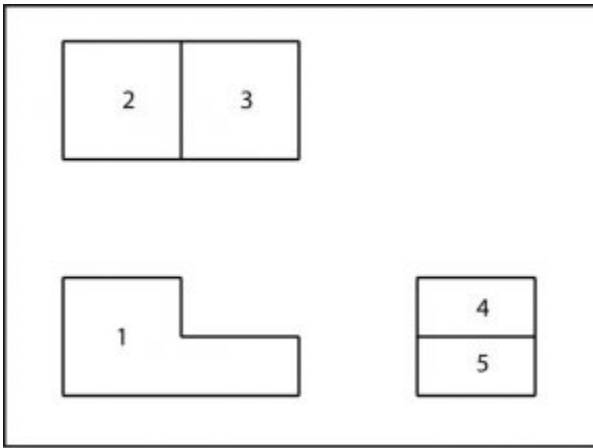

Notice that the front view (1) is the key to the drawing, because it most clearly shows the shape of the object. It tells you the object is “L” shaped from the front. The other two views don’t tell you much by themselves. By looking at surface 1, however, you can see that 2 is taller than 3. Therefore, in “reading” the surfaces, 2 should appear to be closer to you than 3. Now look at 4 and 5. Which surface is projected closest to you?

Answer: Surface 5 (rotate and place at bottom of layout)

Now draw a simple box and tape all sides together to form a cube. The cube will be 2”x 2”x 2”. Once the instructor has approved your drawing you will proceed to cut out and tape edges together to form a cube.

Visualization Quiz

Directions:

All visible surfaces on the objects shown are numbered. To complete this quiz, you are to place those numbers on the corresponding surfaces of the orthographic drawings.

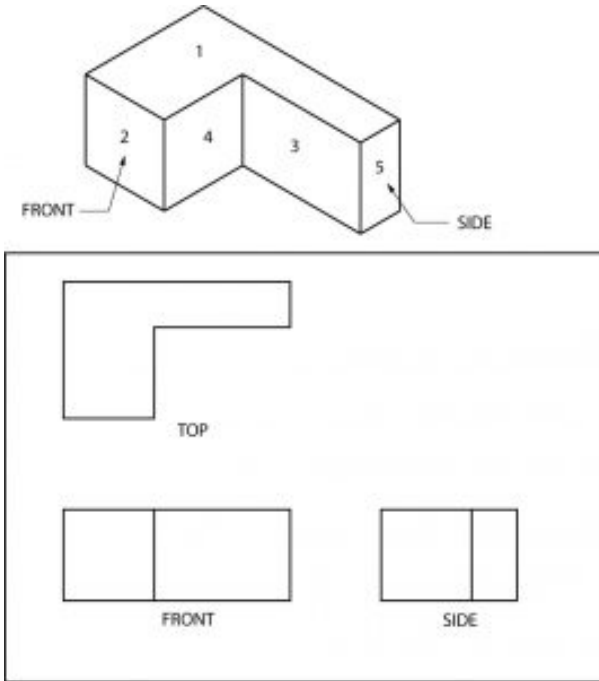

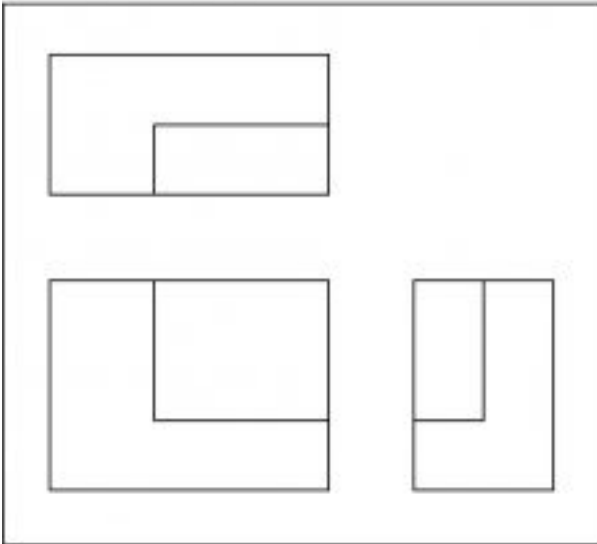
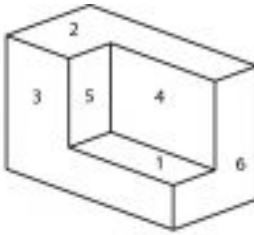

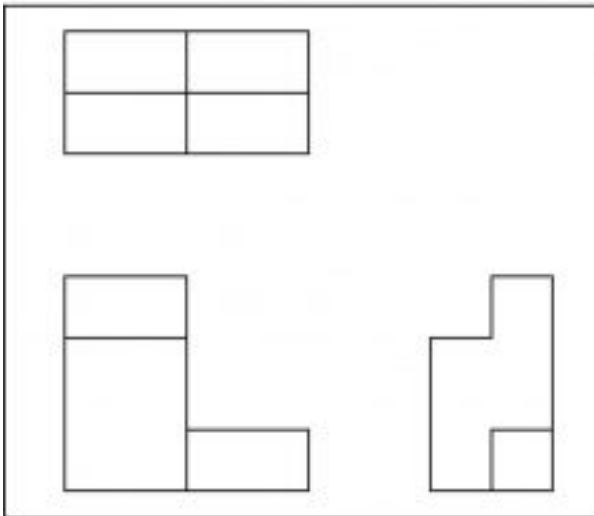
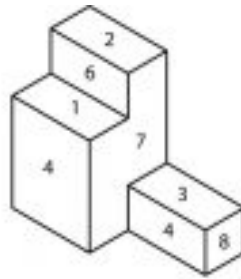

You may be wondering at this point why something like orthographic projection is used on prints when isometric or oblique drawings are so much easier to visualize. The answer is that both of those types of pictorials are used for relatively uncomplicated drawings. When an object is complex, however, neither can equal the orthographic system for clear presentation of dimensions, notes, and configuration details.

Hidden Surfaces

Another advantage of orthographic projection is that it allows the person reading the print to have the ability to see the inside, or surfaces of an object which normally could not be seen.

With complicated objects this can become very useful.

In the drawing below, the hidden line in the right side view represents the entire surface of the flat area between the two higher sides.

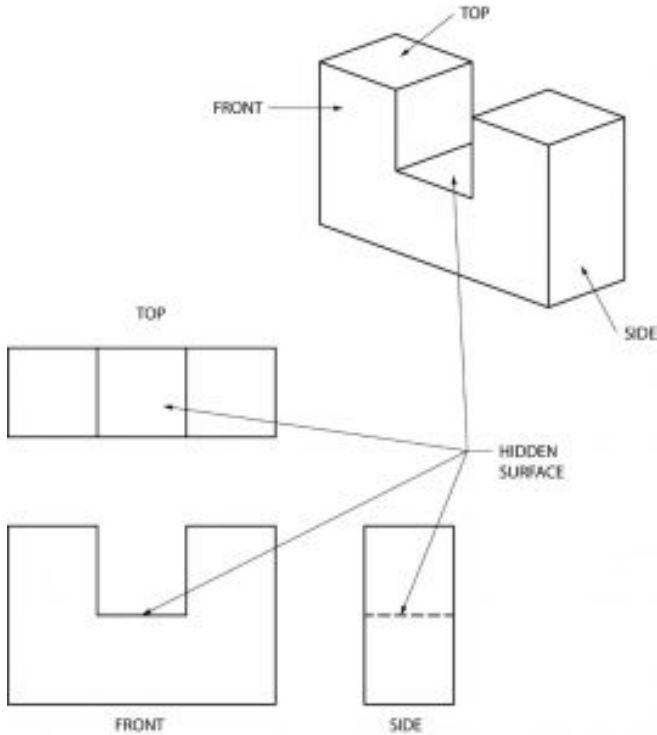

In this example, the hidden lines result from a square hole through the middle of the object.

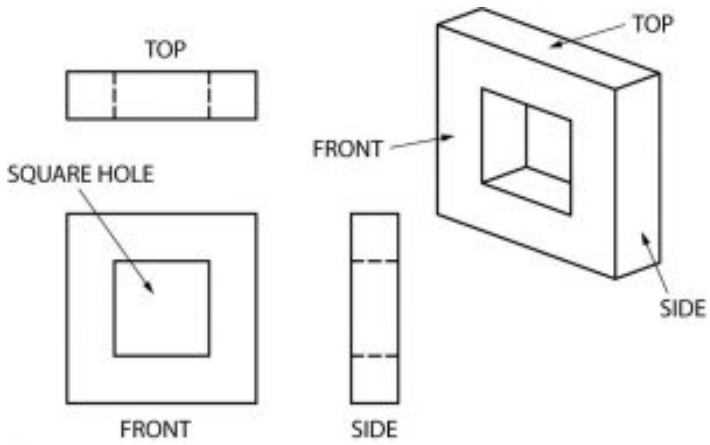

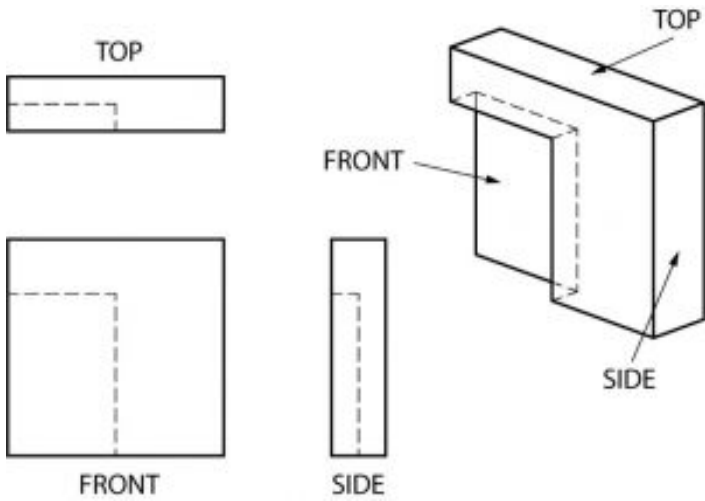

The hidden lines in this example are there because a part of one corner of the front surface was cut away, or “recessed.”

Hidden Surfaces

Directions: Draw the hidden lines which are missing in the views below. Each problem has one incomplete view.

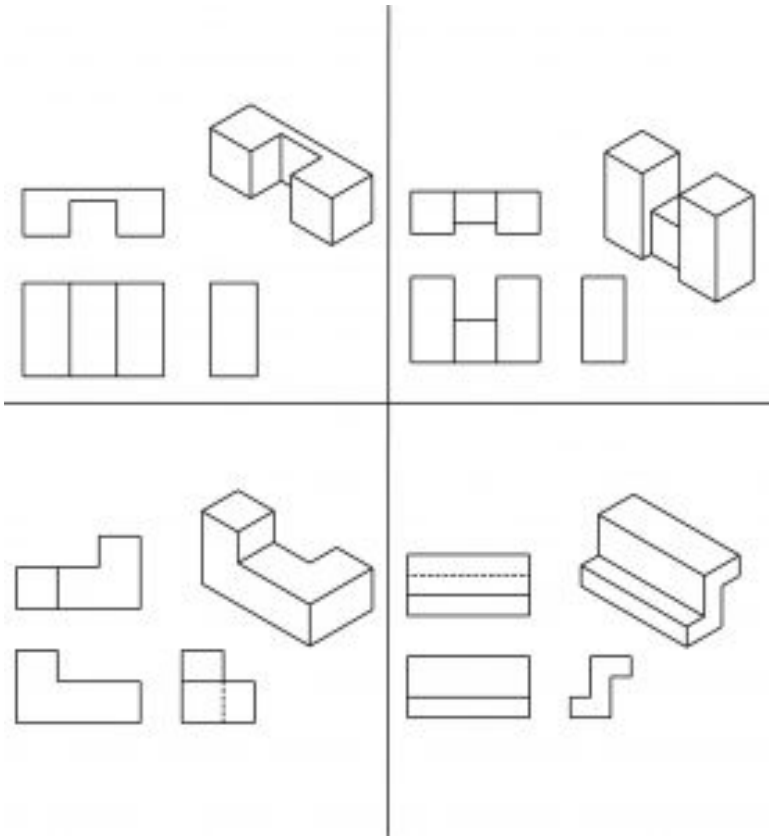

Curved Surfaces

Curved surfaces are perhaps tricky to “see” until you remember that the curve is only shown in one view. You must put the curve in the other views yourself, through visualization. Try to think that when there is a sharp change of direction like at a corner, then that will produce a line visible in another view. When the change of direction is smooth like a curve, no line will be seen.

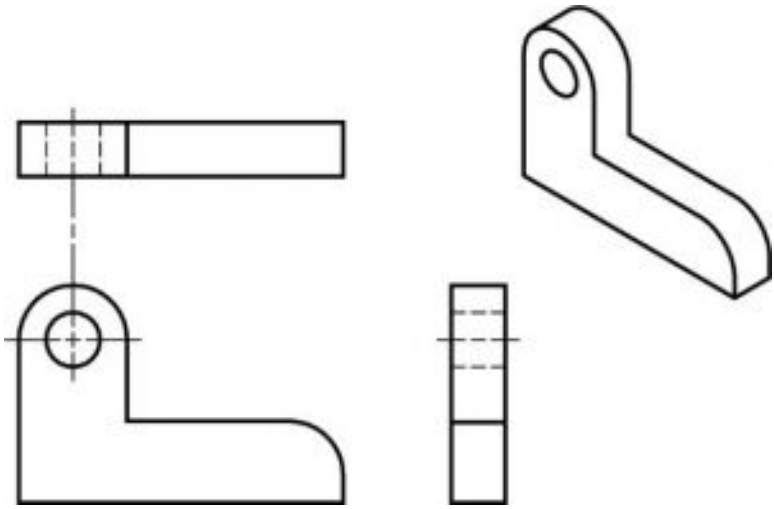

Here's another example of curved surfaces:

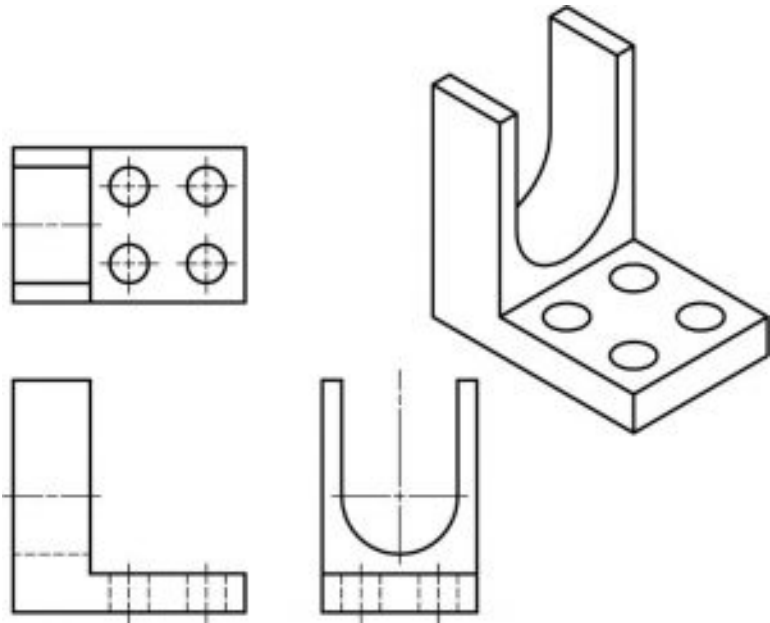

Curved surfaces exercise.

Directions: Draw the lines which are missing in the views below. Each problem has one incomplete view. Do not draw center lines.

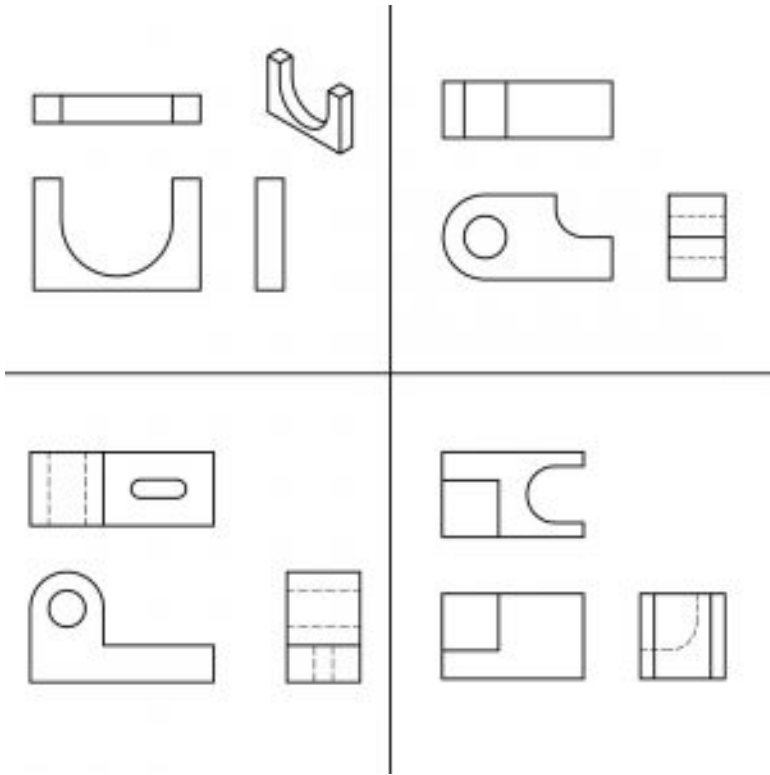

Inclined Surfaces

Inclined surfaces are those which are at an angle, or slanted. In other words, they are surfaces which are neither horizontal nor vertical. In viewing orthographic drawings you need to be alert to angles and inclined surfaces, for they are often found on the prints you will be reading later.

Notice the hidden line in the right view created by the inclined surface on this object:

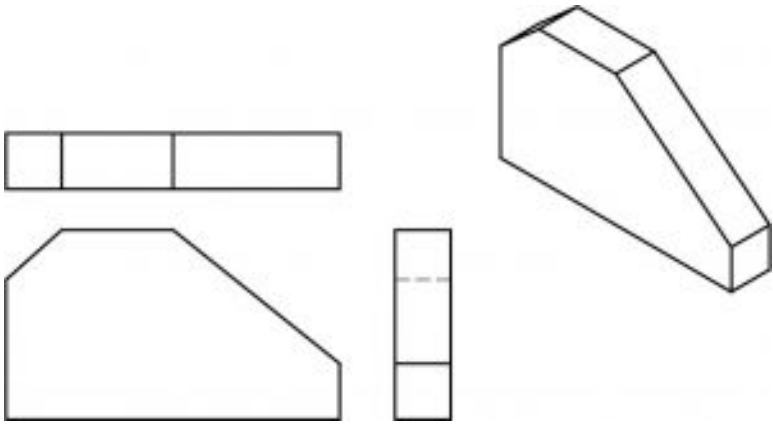

Here is an object with two inclined surfaces.

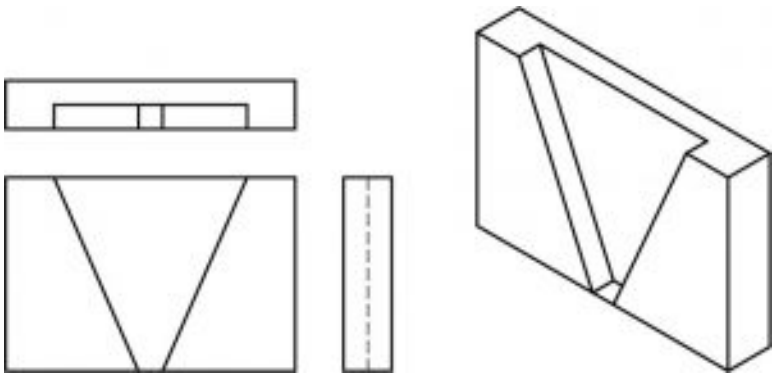

Inclined surfaces exercise

Directions: Draw the lines which are missing in the views below. Each problem has one incomplete view.

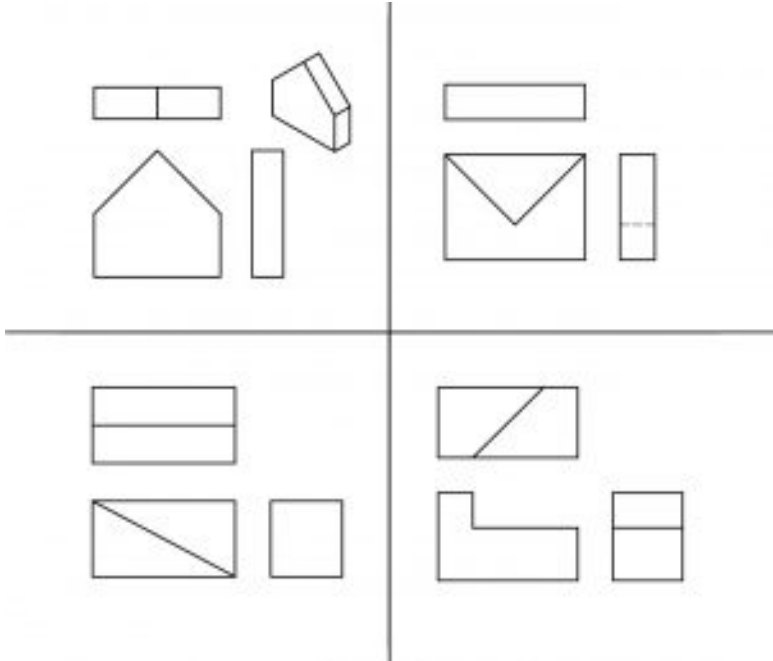

4. Technical Sketching

Technical Sketching

- SKETCHING TECHNIQUES
- LETTERING
- OBLIQUE SKETCHING
- ISOMETRIC SKETCHING
- ORTHOGRAPHIC SKETCHING
- ON-THE-SPOT SKETCHING

On many occasions in your work it will most likely be necessary for you to make a sketch. Perhaps your boss can't visualize a particular problem without one, or you find it's necessary to make a dimensioned sketch to show an apprentice how to complete a job. In any case knowing how to sketch can make you more effective, and therefore more valuable, as a tradesperson.

Many times out in the field you are working on sketches drawn on anything from napkins, cardboard, wood scrapes or any flat surface. Don't get me wrong, you will work projects with professionally produced drawings but sometimes you have to work with what you have.

Being able to make technical sketches doesn't mean you need to be an artist; and sketching isn't difficult if you follow a few simple rules. You may be a little slow at first, but with some practice you will be able to turn out reasonably good sketches without too much effort.

You are not going to be judged as a professional draftsman or architect but you need to be able to describe, with lines what you are

needing built, repaired or modified. This take practice and is a very important skill to develop.

Sketching Techniques

All you need to start is a pencil and some paper. A soft pencil works best for most people, so try a #2 or an F. Keep the pencil sharp, but not too sharp: hold it with a grip firm enough for control, but not so tight that your arm isn't relaxed. Don't draw heavily at first. That way it is easier to erase without smudging. Darken the sketch when it begins to shape up the way you want it.

It's generally best to begin sketching with plain paper, although some people like to use grid paper. On the job, you may find yourself sketching on the back of a work order or piece of packing crate. In any case, it's learning to sketch quickly and effectively that's important.

Here are some limbering up exercises wot get you started. To keep your pencil sharper longer, and for more even lines widths, try turning your pencil slowly while completing the lines in the exercises below.

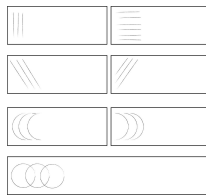

Next, try sketching the objects on this page. Make your sketches as much like the examples as possible.

Remember; sketching means freehand drawing. No Straightedges, compass, coins, etc!

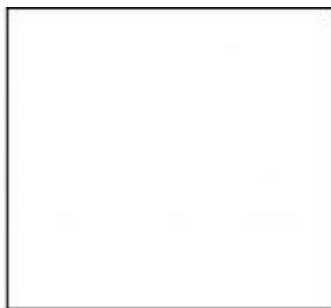
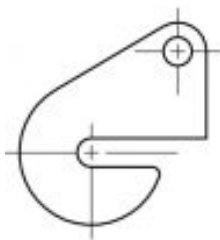

Lettering

Now that you are warmed up, we will take the straight and curved lines from the sketching exercise and use them to form letters. The entire alphabet can be formed from the straight and curved lines you have practiced.

Look at the lettering below. If your printing is similar, and is easily readable, you can skip this exercise and go on to oblique sketching. If not, do some practicing. Some of the work ahead (and tests) require good lettering.

Remember, the most important requirement of good lettering is

legibility. There is no use making a drawing if the person looking at drawing cannot read your writing.

A	N
B	O
C	P
D	Q
E	R
F	S
G	T
H	U
I	V
J	W
K	X
L	Y
M	Z

Oblique Sketching

Oblique sketches are a type of pictorial having one plane parallel to the drawing surface, and the visible side sketched at an angle. Usually, that angle works best at 30° to 45° , or somewhat in between. Beginners often have trouble keeping the 30° or 45° lines as the same angle. If that happens, your sketch will look distorted.

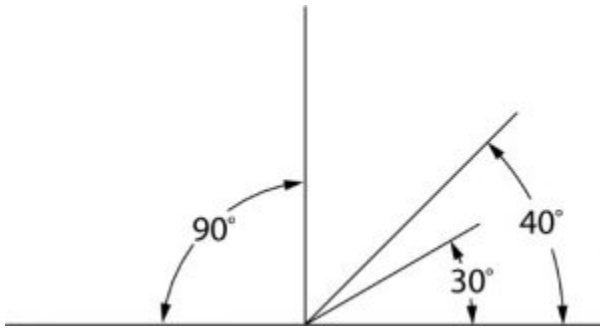

Here's how to sketch an oblique cube in three steps:

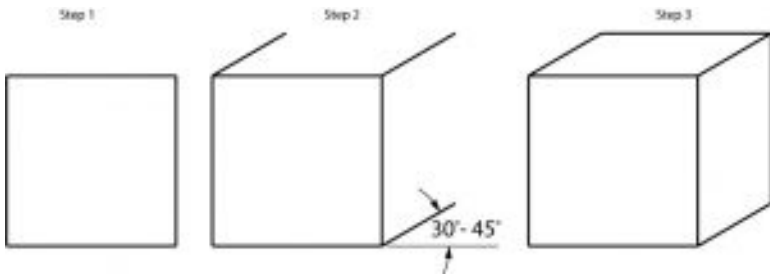

Possibly you might want to show the left side of the cube, or perhaps draw the hidden lines, as at the right;

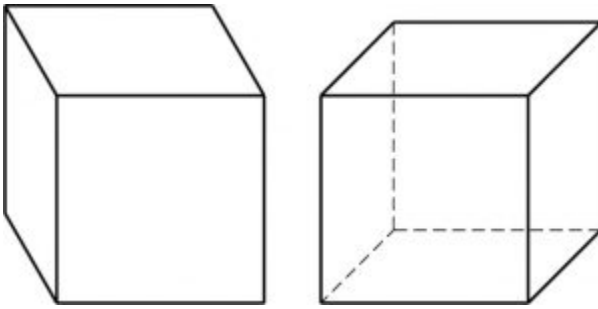

In the spaces below, sketch oblique cubes as indicated.
Sketch these objects in oblique, as shown:

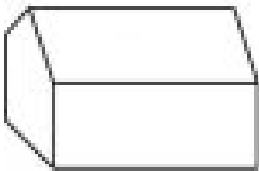
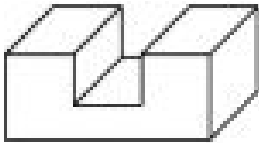
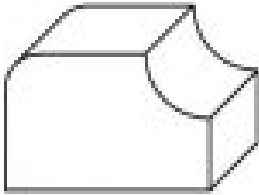
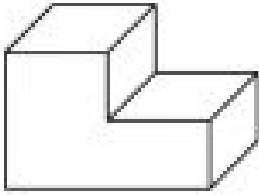

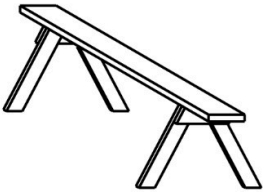
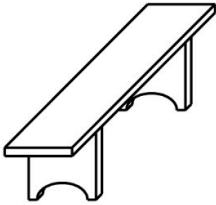
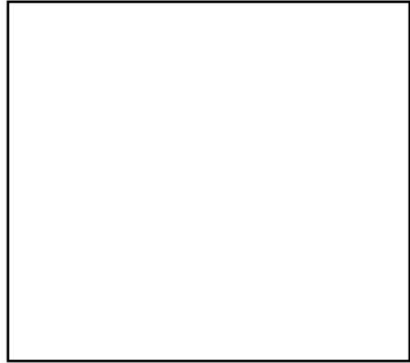
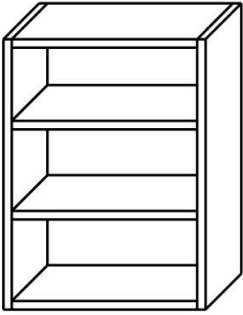

In this more difficult exercise, you are to make oblique sketches of the objects shown. The third problem is drawn in isometric. You are

to sketch it in oblique. Convert problem four from orthographic to an oblique sketch.

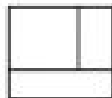
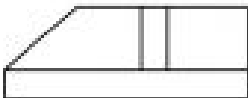
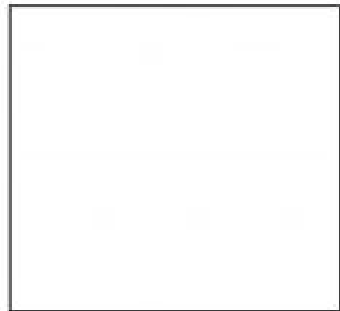
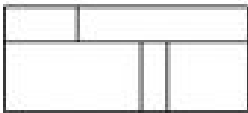
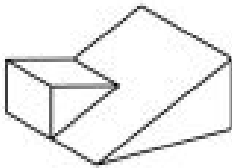
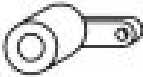
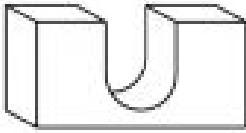

Isometric Sketching

Isometric sketches, unlike oblique, must maintain an angle very close to 30°.

Therefore, to get the “feel” of an isometric, try sketching 30° angles in this exercise:



Sketching in isometric can be done in different ways. Generally, it's recommended that you start with the bottom of the object and “box it in”, thereby enclosing it within a rectangular framework. For example, if we were to take a simple object like this,

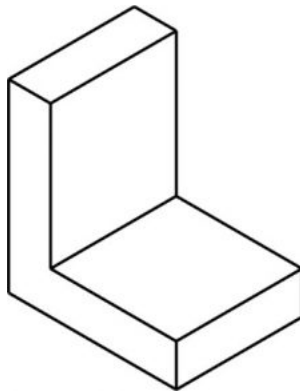

The steps needed to sketch it in isometric would be;

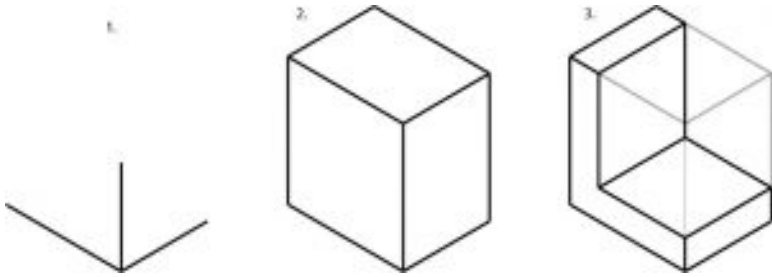

The unnecessary lines are then removed, leaving the object. Once you gain some practice at this, it will be possible for you to make an ISO drawing without the “guide” lines. It is important to use them early on the help train your brain.

To the beginner, building a “frame” before sketching the object often seems unnecessary. That may be true with simple objects. However, when things become more complex, a frame gives you a means of developing the various parts in an organized way. Without such guidelines you can easily “lose” your sketch.

Sketch the examples given, using guidelines as shown in the first exercise. Draw the guidelines lightly. Notice that 3 and 5 require the use of non-isometric lines. Since those lines are not at 30° , it is best to connect the end points of those lines after the sketch nears completion.

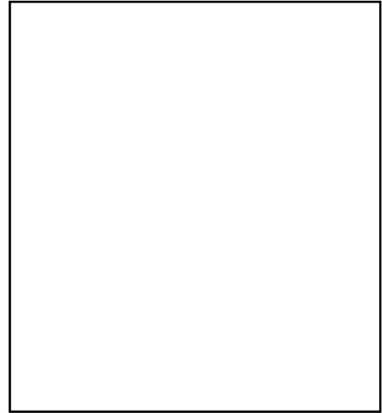
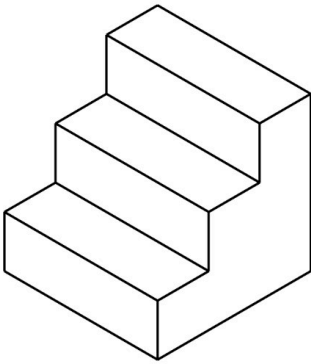
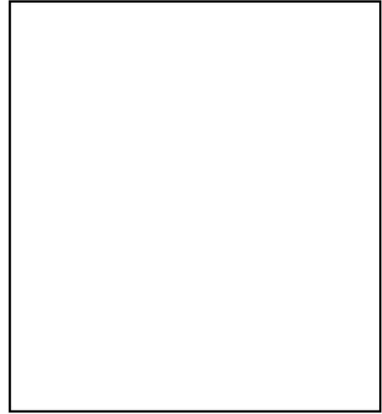
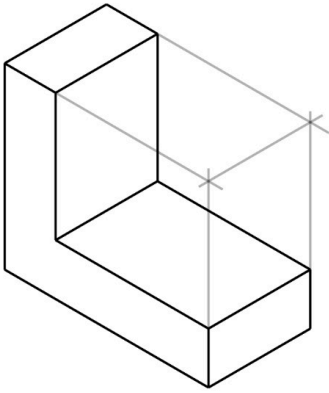

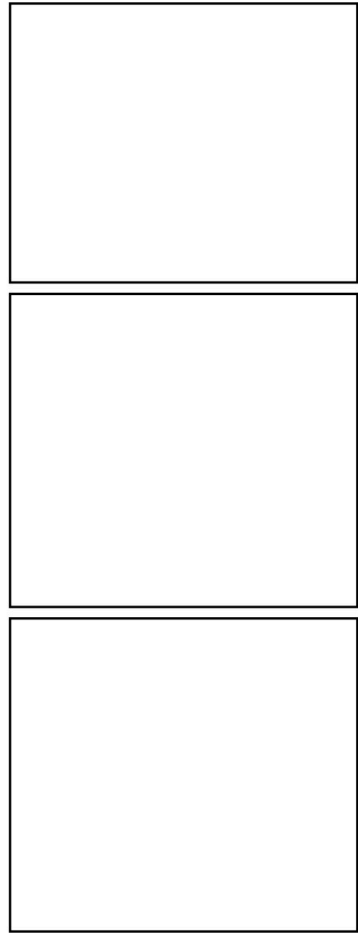
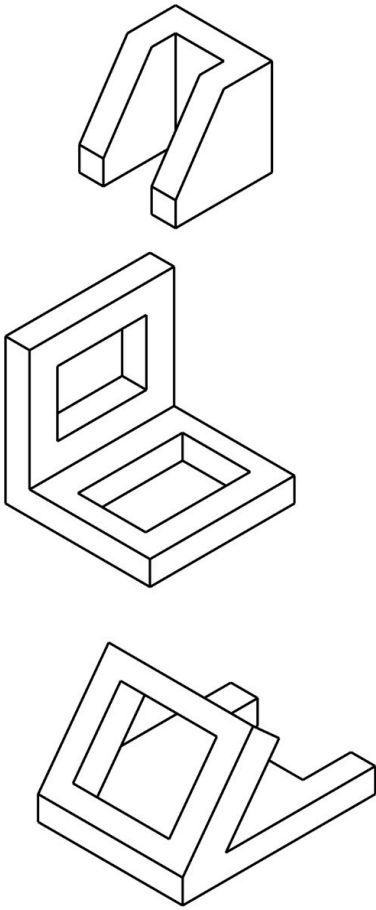

Circles and arcs, when sketched in isometric, become elliptical in shape. If a circle is used, it will appear distorted, as in this example:

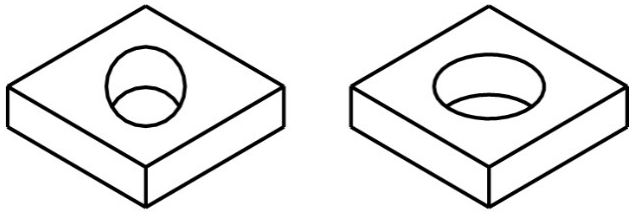

In sketching isometric circles and arcs, there are three positions in which they are normally sketched, depending upon the surface where the circular feature is located. Those surfaces, or picture planes are:

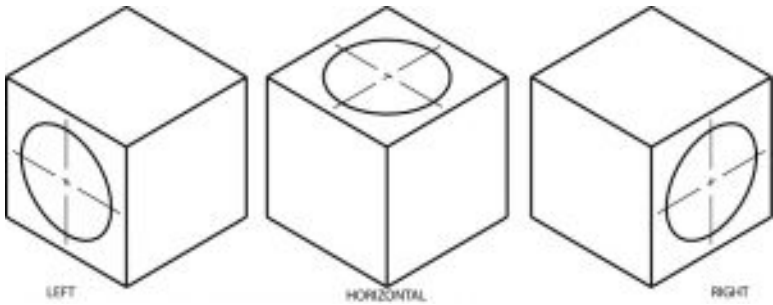

On the cube shapes below sketch ellipses as on the examples above.

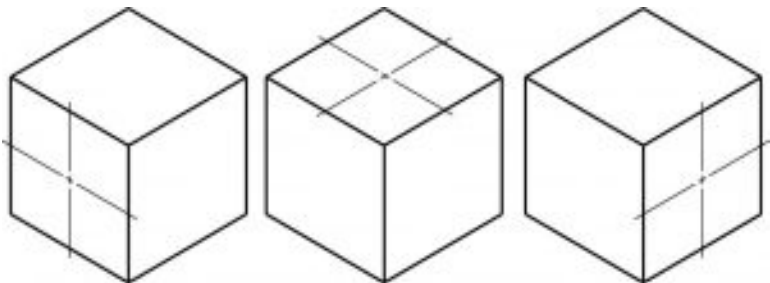

You may also want to practice sketching ellipses on the other surfaces of the cubes.

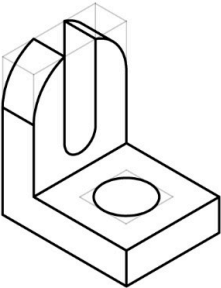
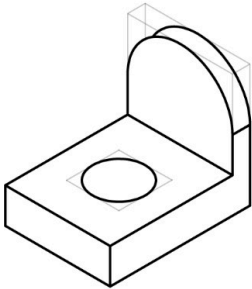
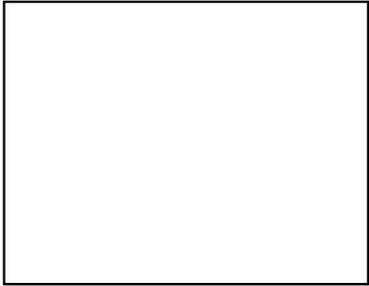
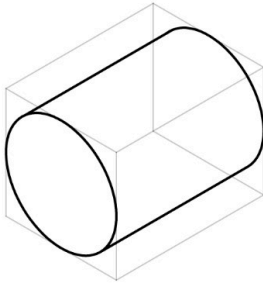

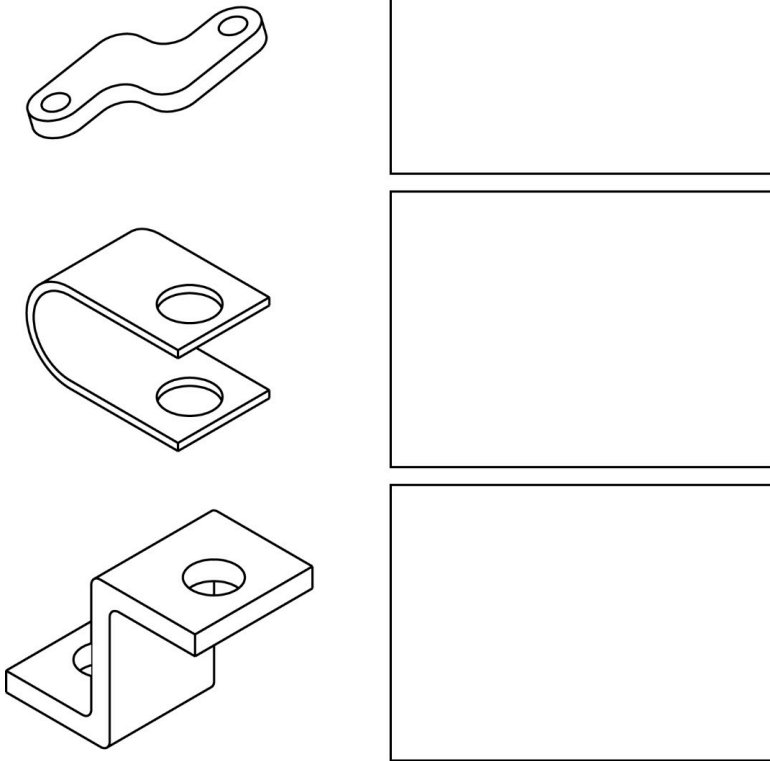

Orthographic Sketching

Of all the methods of making drawings, orthographic projection is the most commonly used by draftsperson. Although the other methods serve their purposes, they cannot always show the parts of an object as well as orthographic representation.

Orthographic projection is a system of projecting from view to view to graphically describe the object. As a way of reviewing, study the

views of the small garage in this drawing. Notice the location and relationship of each view to the other views.

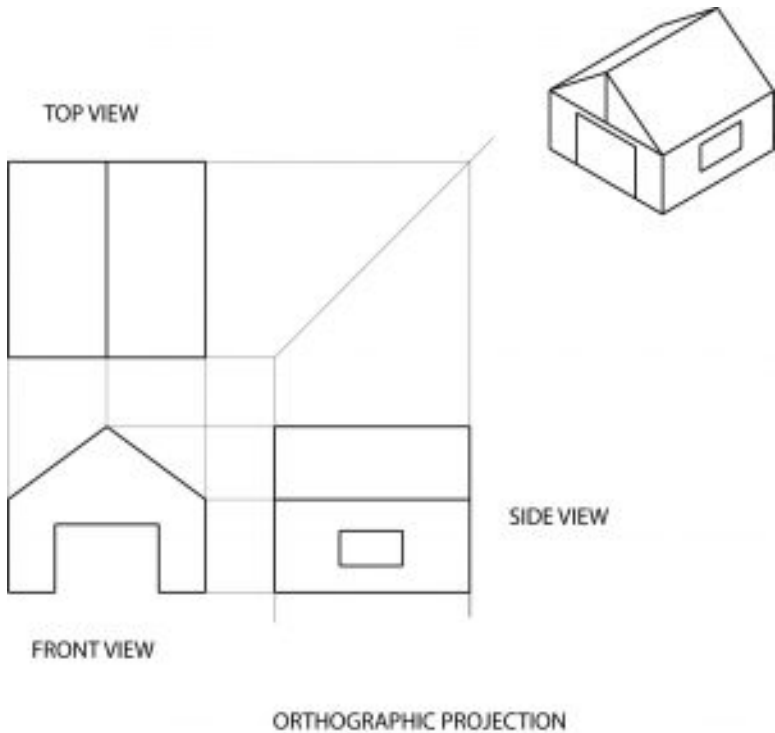

The important thing to remember in orthographic sketching is the alignment of views. The top view is projected directly above the front view. The front and side view also line up with each other. The height, width, and length of the object must remain the same from view to view. There should be enough distance between the views to prevent crowding; and to leave room for dimensions.

Produce a top view in the drawing below.

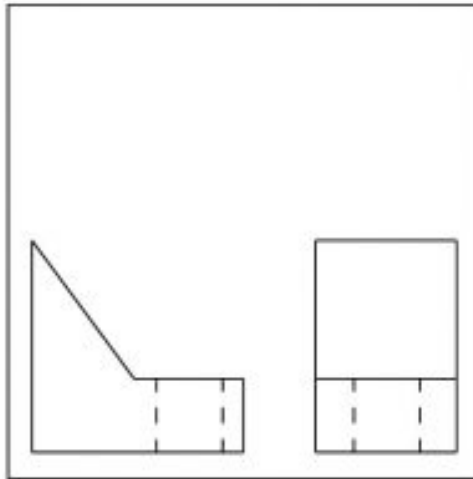
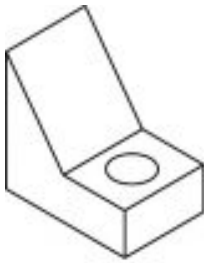

Sketch each object in orthographic in the spaces on the right. Remember, the idea is to project! Front, top and right side view.

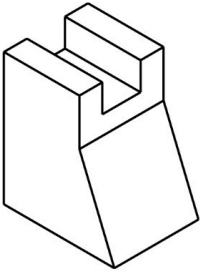
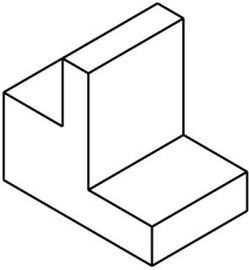
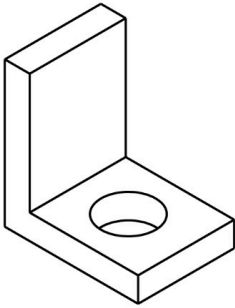

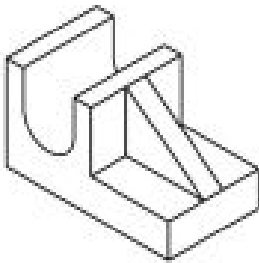
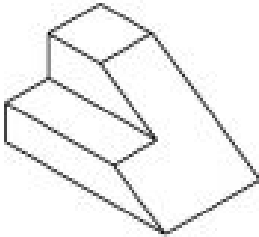
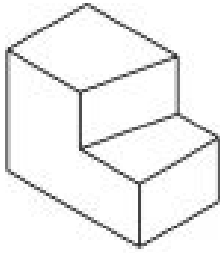

“On-THE-SPOT” Sketching

Now that you have learned the three different methods of sketching, it is time to make sketches you can place in front of you and touch, rather than sketching from drawings on paper.

Sketching “ON-THE-SPOT” is a standard industry practice. A piece

of machinery needs to be changed, a support needs to be added, or pictorial information in some way requires a sketch.

Instructor will give you an object to sketch...

You will need to produce an isometric of the object and also an orthographic drawing with as many views as required to show details of object to be built.