

A photograph of a modern interior space. A person is standing in a brightly lit area with a strong red glow, looking out through a glass wall. To the right, a staircase with dark steps and a metal railing leads upwards. The overall atmosphere is dramatic and architectural.

INTERIOR MATERIALITY

kutay guler

NEW PRAIRIE PRESS

9-1-2021

Interior Materiality

Kutay Guler
Kansas State University

Follow this and additional works at: <https://newprairiepress.org/ebooks>



Part of the [Interior Architecture Commons](#), and the [Interior Design Commons](#)



This work is licensed under a [Creative Commons Attribution-Noncommercial 4.0 License](#)

Recommended Citation

Guler, Kutay, "Interior Materiality" (2021). *NPP eBooks*. 42.
<https://newprairiepress.org/ebooks/42>

This Book is brought to you for free and open access by the Monographs at New Prairie Press. It has been accepted for inclusion in NPP eBooks by an authorized administrator of New Prairie Press. For more information, please contact cads@k-state.edu.

INTERIOR MATERIALITY

Kutay Guler

NEW PRAIRIE PRESS
MANHATTAN

Copyright © 2021 Kutay Guler

New Prairie Press
Kansas State University Libraries
Manhattan, Kansas

Cover design by Kutay Guler
Cover Image © iStock, 2021

Electronic editions available online at:
<http://newprairiepress.org/ebooks/42/>

This work is licensed under a [Creative Commons Attribution-Non Commercial 4.0 International License](https://creativecommons.org/licenses/by-nc/4.0/), except where otherwise noted.



ISBN: 978-1-944548-38-4

NEW prairie PRESS
open access scholarly publishing

CONTENTS

PREFACE	4
<hr/>	
CHAPTER 01 INTRODUCTION	6
A BRIEF HISTORY OF MATERIALITY	8
MATERIAL PERFORMANCE	13
SURFACE ATTRIBUTES	15
WEATHERING AND AGING	16
<hr/>	
CHAPTER 02 PERCEPTION	18
VISUAL NATURE OF MATERIALS	22
NON-VISUAL SENSES	30
<hr/>	
CHAPTER 03 HEALTH & SAFETY	32
STANDARDS	34
FIRE SAFETY	35
ACCESSIBILITY AND UNIVERSAL DESIGN	37

INDOOR AIR QUALITY (IAQ)	41
HARMFUL CHEMICALS	43
ROOM ACOUSTICS	47

CHAPTER 04
SUSTAINABILITY **54**

CARBON FOOTPRINT	57
RECYCLING	58
GREEN BUILDING CERTIFICATION	61
ECO-LABELS	62
GREEN CLEANING STRATEGIES	64

CHAPTER 05
PAINT & WALLCOVERING **66**

GYPSUM & PLASTER	71
PAINT APPLICATION	74
WALLCOVERINGS	77
WALLCOVERING APPLICATION	81

CHAPTER 06
CONCRETE & MASONRY **82**

BRICK	87
STONE	90

CHAPTER 07
WOOD **96**

GENERAL PROPERTIES	98
SPECIES	103
PROCESSING	108
VENEERS	112
ENGINEERED WOOD	115

CHAPTER 08
GLASS & CERAMIC **120**

SPECIFYING GLASS	123
CERAMICS AND PORCELAIN	128
SPECIFYING CERAMICS	130

CHAPTER 09
TEXTILE **136**

NATURAL FIBERS	139
SYNTHETIC FIBERS	141
TEXTILE SPECIFICATION	144
LEATHER	149
CARPET	152
CARPET INSTALLATION	157
UPHOLSTERY	160
SOFTGOODS	162

CHAPTER 10
METAL **166**

PROCESSING METALS	169
FINISHING METALS	172
FERROUS METALS	174
NON-FERROUS METALS	178

CHAPTER 11
PLASTIC **182**

PLASTIC TYPES	186
THERMOPLASTICS	187
THERMOSETS	194
MANUFACTURING METHODS	197
COMPOSITES	200
INTERIOR SPECIFIC PRODUCTS	202

CHAPTER 12
SPECIFICATION **206**

COST ESTIMATION	211
SPECIFICATION CRITERIA	216

SELECTED BIBLIOGRAPHY **230**

IMAGE CREDITS **232**

INDEX **244**

PREFACE

The knowledge of materials and finishes is the bridge that links conceptual design to real-world application. It is among the core content of virtually all interior architecture/design curricula, moreover, access to up-to-date information on emerging technologies and trends is a key exigency for the contemporary designer. Accordingly, this book is authored to form a comprehensive resource for the “hows” and “whys” surrounding the functional and aesthetic contributions of a wide selection of materials and finishes used in multiple spatial design contexts. The knowledge base presented here is not only useful in shaping spatial experience, ensuring occupant well-being, and employing sustainable thinking but also beneficial in managing budget and schedule while enabling the delivery of top-quality work.

The book investigates fundamental material properties, performance criteria, as well as sector-specific standards, regulations, and guidelines, with a special focus on concerns surrounding occupant health and safety as well

as environmental impact and sustainability concerns. Furthermore, fabrication, installation, and maintenance issues were explored in detail. Various information collection and organization conventions are also discussed with regard to detailing, specification, estimation, and documentation of materials and finishes.

The goals of the book can be listed as follows:

- Developing a vocabulary and knowledge base to comprehend and communicate concepts and paradigms associated with the history, classification, manufacturing, evaluation, fabrication, installation, and maintenance of materials and finishes.
- Identifying a broad range of materials and finishes, considering their aesthetic and performance properties, and understanding their utilization with regard to creative design intent, client expectations and requirements, user needs and experience, and incorporating life cycle implications.
- Providing a basis for achieving physical and psychological well-being for occupants, understanding the impact of changing social, cultural, economic, and ecological context, and eliminating negative environmental and social outcomes.

The book is structured around building a solid foundation first, and subsequently, exploring each material category separately. The first four chapters are dedicated to the comprehension of fundamental vocabulary, material perception, health and safety considerations, accessible design, and sustainable thinking. Each subsequent chapter is dedicated to a specific category of material: paint and wallcovering, concrete and masonry, wood, glass and porcelain, textile, metal, and plastic. The last chapter is dedicated to the specification of materials and the responsibilities of the designer in the process. The chapter also emphasizes the importance of cost estimation and provides a step-by-step guide. Finally, a large selection of material specification criteria is outlined in detail with examples, to help the designer identify the best possible materials for their project.

Tab.00/01 Detailed content of and related CIDA 2020 accreditation criteria for each chapter.

Chapter	Content	Accreditation
01	INTRODUCTION Definition of material and materiality; relevance of material knowledge; a brief history of materiality; performance properties; surface attributes; foundational terminology; weathering and aging.	<i>CIDA 10b, 10e, 13a,</i>
	PERCEPTION Perception of materiality; understanding design trends; historical, cultural, and design context; concept driven material specification; visual elements and principles; balance, dynamism, and composition; non-visual senses.	<i>CIDA 4a, 4b, 6c, 12a, 12i, 13a, 15d</i>
03	HEALTH & SAFETY Building codes and standards; fire safety; the Americans with Disabilities Act; ADA accessibility guidelines; universal design principles; indoor air quality (IAQ); harmful chemicals; room acoustics and reverberation; sound transmission and flanking.	<i>CIDA 4b, 13c, 14a, 14b, 14c, 14f, 14h, 14i, 16c</i>
	SUSTAINABILITY Sustainable thinking and design; carbon footprint; embodied energy and recycling; life cycle assessment (LCA); green building certification; eco-labels; green cleaning practices.	<i>CIDA 4a, 4b, 13c, 16b</i>
05	PAINT & WALLCOVERING Typical paint components; paint history and types; gypsum and plaster; paint application and disposal; wallcovering history and types; wallcovering application.	<i>CIDA 13a, 13b, 13c, 14h, 14i, 15d, 16c</i>
	CONCRETE & MASONRY Vocabulary for concrete; concrete types and application; terrazzo and installation; brick types and installation; vocabulary for natural stone, quarrying and environmental impact; stone types and finishes; stone installation and maintenance.	<i>CIDA 13a, 13b, 13c, 15d, 16c</i>
07	WOOD Vocabulary for wood products; forest management; performance properties and behavior; prominent wood species; processing and finishing; wood veneers; engineered woods.	<i>CIDA 13a, 13b, 13c, 14h, 14i, 15d, 16c</i>
	GLASS & CERAMIC Glass - history and vocabulary, light transmission, environmental impact and recycling, specification and fabrication. Ceramics and porcelain - manufacturing process, environmental impact, ceramic types and properties, specification and installation.	<i>CIDA 13a, 13b, 13c, 15d, 16c</i>
09	TEXTILE Textile vocabulary; environmental impact of textiles; fiber types and yarn construction; natural and synthetic fibers; textile manufacturing and performance; leather; carpet construction and types; carpet installation; upholstery and soft goods.	<i>CIDA 13a, 13b, 13c, 14h, 14i, 15d, 16c</i>
	METAL Core terminology for metals; metal alloys; corrosion, weathering, and patina; processing metals; finishing metals; ferrous metals; non-ferrous metals.	<i>CIDA 13a, 13b, 13c, 15d, 16c</i>
11	PLASTIC Polymers and plastics; synthesis and key additives; environmental impact of plastics; resin identification code and recycling; common thermoplastics and thermosets; plastic manufacturing methods; composites; polymer products specific to interiors.	<i>CIDA 13a, 13b, 13c, 14h, 14i, 15d, 16c</i>
	SPECIFICATION The business and key professionals; common specification types; standardized specification content; project cost estimation; conducting field survey; criteria for successful specification.	<i>CIDA 5a, 6a, 6c, 6d, 13a, 13b, 13c, 16c</i>

*Criteria 13d and 13e are omitted above as they require a student application example.

01

INTRODUCTION

- *Definition of material and materiality*
- *Relevance of material knowledge*
- *A brief history of materiality*
- *Performance properties*
- *Surface attributes*
- *Foundational terminology*
- *Weathering and aging*

The word **material** refers to a substance that can be manipulated through industrial processes and procedures, into components, finishes, products, or structures to realize design intent. Whether a doorknob, or a flooring tile, or a movable room divider, every part of the interior space is manufactured involving at least one material, but more commonly a combination of several materials working together in a way that best utilizes their performance and aesthetic qualities.

The important question is “why is it crucial to learn about materials?” The design process typically involves developing an initial conceptual idea to an extent that it is ready to be fabricated, manufactured, or built as a useful real-world entity. This “**realization**” of the design intent requires a knowledge of how various materials are manufactured, processed, combined, and finished. The designer’s career depends on their ability to understand and evaluate materials’ aesthetic and performance parameters,



Fig.01/01 Materials and finishes, by working in conjunction, determine the overall impact of the interior space.

while maintaining an ethical, exploratory, and creative outlook. This is true even when working on purely conceptual designs; as soon as the intent needs to be realized, for instance an artistic vision as a conceptual art piece to be exhibited, the designer is required to tap into their knowledge of materials. Among many successful contemporary artists Anish Kapoor has worked with top materials scientists and engineers to realize his art, Richard Serra developed a deep understanding of the materials that he utilized as a medium of expression, or Carl Andre dedicated his art to exploring and understanding what various materials were about.

*In summary an ability to creatively and successfully **realize design intent** depends on an extensive knowledge of materials.*

Materials can be categorized in various ways. A categorization system that is highly relevant for interior architects and designers is the **MasterFormat®**, the specifications writing standard for most large-scale design and construction projects in North America. Developed and published by the Construction Specifications Institute (CSI), **MasterFormat®** is organized around categorizing

the construction requirements, products, and activities related to various materials, products, components, and systems.

Within the context of interior architecture and design, one can simply classify materials as they relate to floors, walls, ceilings, and millwork/casework. This is especially useful when trying to specify materials for interior surfaces, every relevant option is categorized together and alternatives can be compared relatively quickly. The downside for this categorization approach is the repetition of each class of materials for each particular interior component.

A more **traditional** and straightforward categorization of materials would be metals, ceramics, minerals, polymers, composites, plant-based, and animal-based materials. This book is structured around this particular categorization logic. However, some categories such as paint and wallcovering, concrete and natural stone, wood, and textiles are separated for clarity and convenience, even though each of these added categories can fit in one or more of the mentioned traditional categories. For example, wood is in fact a polymer composite.

Litracon© - Light-transmitting concrete | www.litracon.hu



Fig.01/02 The translucent Litracon® is utilizing the same fundamental principle as mud brick.

A BRIEF HISTORY OF MATERIALITY

Soon as a stone fragment was chipped by a human to form a sharp edge, materiality became relevant. So relevant that there are whole periods in history named based on the impact of certain materials on how historical events unveiled and how people sustained their day-to-day activities. Humanity lived through the stone, copper, bronze, and iron ages; and, maybe in the future the contemporary times will be referred to as the semiconductor or nanomaterial age.

Every material has an association within the collective memory of a society. **Zeitgeist** is a popular term that is often translated as the ghost/spirit of the time/era, which implies that meaning and significance of any notion, including the creative use of materials and manufacturing methods, is a product of their time and they will be engrained in culture accordingly.

The knowledge of the **semantic associations** of when, why, and in what context a material and manufacturing technology became popular can be utilized to construct meaning and atmosphere, create a sense of place and time, and evoke an emotional response.

For instance, mahogany wall paneling might evoke a feeling of Victorian sophistication, or a glossy, bright and colorful vinyl fabric can be used to set a futuristic atmosphere, or polished white marble can reference neo-classic ideals.

HUMBLE BEGINNINGS ● Even though there are much earlier examples of straw huts and cave paintings created with prepared pigments, if the manufacturing of an actual building product is considered, it can be said that the humble beginnings of materiality coincide with sun-dried bricks around 7000 BCE in Mesopotamia. With the integration of plant fibers into a mud mixture,



Fig.01/03 A view from the Ishtar Gate reconstruction situated in Pergamon Museum, Berlin.

early bricks became the first composites. In 2006 Litracon®, a translucent concrete building material permitted the passage of light through concrete via latitudinally integrated glass fibers. It presented an impressive marriage of ancient and contemporary materials and techniques to create unexpected effects in a highly traditional material.

GLAZED TILES ● Throughout the globe from Africa to North America, pottery is chief among the most common archaeological findings, along with tools and fossils. Pottery is simply formed and fired clay. The firing process helps the material withstand decay over time, early archaeological evidence dating almost 10,000 years back.

Glazing, the fused glassy coating on fired clay products, came much later. The Ishtar Gate, built around 575 BCE features one of the first uses of glazed tiles. Kiln-dried bricks were applied with a coating and through exposure to intense heat, various vivid colors, as well as protection, was achieved. This ended up being the precursor of the modern ceramic tile.

OPUS CAEMENTICIUM ● Concrete is part of virtually every contemporary construction, whether it is used to set a foundation or to create a tube structure for a high-rise building, board-formed for decorative finishing interiors or poured over to create a durable substrate. Ancient Romans were the first to successfully implement concrete on an industrial scale. Cement, a heated and ground limestone and clay mixture, enabled Romans to develop concrete and build the 142 feet wide dome of Pantheon in 126 CE. After the fall of the Roman Empire, the technology was almost lost until the end of the 18th century.

via.01/01 Video on making bricks with primitive technology.



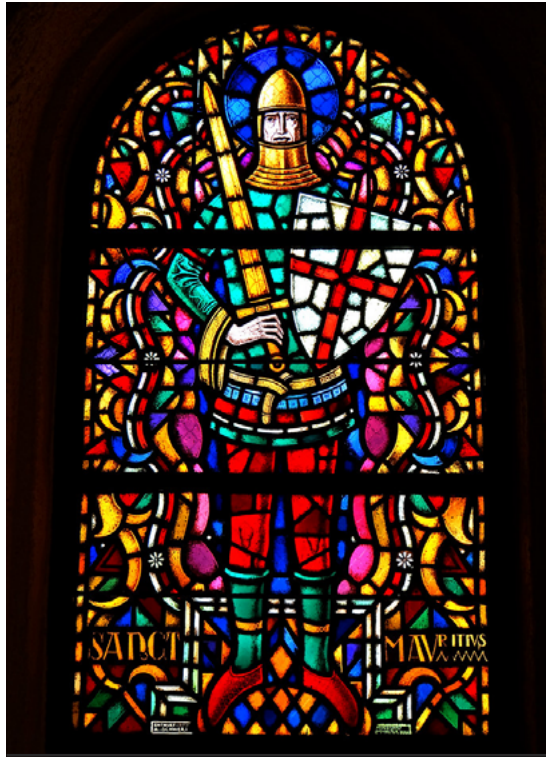

Fig.01/04 Stained glass windows often depicted religious stories or figures in vivid colors.

LETTING LIGHT IN • Glassmaking requires very high temperatures, mainly to melt and purify silica, the major raw constituent of glass. Humankind did not achieve the required technology until medieval times. The naturally occurring volcanic glass, which is known as obsidian, or glass formed after a meteoric impact such as Moldavite were the first glass materials to be used since Stone Age. Around the 12th century, the Romanesque stained glass expressing religious themes, became a precursor to the large stained glass windows that were later associated with Gothic cathedrals. Glass became part of the architectural language with the mass manufacture of broad sheet glass in 1226, in Sussex, UK. Today, manufacturing became so reliable and feasible that whole skyscrapers can be enveloped with glass.

AUTOMATION REPLACING JOBS • The industrial revolution enabled the manufacture and widespread use of some known materials in extraordinary quantities, chiefly among them, iron and later steel, replacing the traditional wood, brick, and stone. Entire buildings were made from iron, one of the most famous being the Eiffel Tower, still standing in Paris, France. As the Industrial Revolution ensued, textile manufacturing technology also advanced. In 1784 Edmund Cartwright invented the power loom, mechanizing textile production, enabling cheap access to a variety of textile products, but also impacting a whole branch of skilled labor by automating a process ultimately catalyzing civil unrest and social change.

NATURAL VS. SYNTHESIZED • Rubber as a naturally occurring polymer has been known since 1300 BCE, however, following the industrial revolution, new venues of use for this flexible and resilient material were discovered, such as transmission belts and pneumatic tires, which



Fig.01/05 Latex being extracted from a rubber tree.



Fig.01/06 Bakelite considerably shaped product design of the early 20th century.

skyrocketed demand. Rubber plantations in various regions with tropical climates became widespread around the late 19th century. In addition to intense deforestation, some of the plantations, such as those in Congo, were associated with deep human drama. Starting from the 1910s until the 1940s synthesized rubber was perfected to become a feasible alternative, not completely replacing but greatly reducing dependency on natural rubber.

BETTER LIVING THROUGH CHEMISTRY ● The first example of synthesized polymers started appearing as early as the 1830s. Like many other early polymers, formaldehyde was discovered in 1859, while attempting to synthesize something else. The commercial production of formaldehyde took off towards the end of the 19th century. Phenol-formaldehyde resin became an important component for Bakelite manufacturing, the world's first totally synthetic thermosetting plastic, invented in 1907. Bakelite was advertised as a "material with a thousand uses", with only two colors available at first, brown and darker brown. In the 1930s melamine based on melamine-formaldehyde, became a replacement for Bakelite enabling vivid colors



Fig.01/07 The curves and flowing lines of the Thonet chair is achieved by steam bending wood.

and a smooth finish. It is somewhat ironic that plastics replaced completely unsustainable and at times cruel rubber, ivory, silk, etc. manufacturing, however, today they became a sustainability problem due to overproduction and their persistence in nature.

MANIPULATING WOOD ● Even though it was possible to cut and carve wood into any desired shape, it was time-consuming manual labor and required skilled craftsmanship. The Thonet Chair introduced by Michael Thonet in 1859 utilized steam to bend wood pieces, achieving components with true curvilinearity. More importantly, it was possible to mass-produce these components. Millions of Thonet chairs were produced in the subsequent years. Similar bending and molding methods were successfully applied by many designers including Alvar Aalto, Eero Saarinen, and more famously by Charles and Ray Eames. Steam bent plywood is an important aspect of the Eames Chair and Ottoman, which is still a valued addition to high-end offices and living rooms today.

STEEL REPLACING STYLE ● The very durable Damascus steel was being manufactured a thousand years before the industrial revolution and used

for building swords and armor. However, it took a technological breakthrough to mass manufacture steel. The Bessemer Conversion, enabled its feasible production in industrial quantities. Cheap steel ended up transforming architecture by successfully replacing masonry and timber. With the advent of International Style, steel along with glass and concrete became an expression of material potential, replacing previous stylistic conventions, at least for a while. Furniture design was also being transformed by reliable and cheap steel. Wassily Chair (Model B3), designed by Marcel Breuer in 1926 employed steel tubing in furniture first time.

WEAVING CARBON ● In 1940, the development of the combination of polymer resin and glass fibers resulted in Glass Reinforced Plastic (GRP), a lightweight and high-performance material to be used in structural applications. The aeronautical industry pushed the development of different types of composites, including high-performance metals in the equation. Carbon-fiber, which is essentially a carbon lattice set in resin, is one of the most widely known composites, partly due to its unique look, outperforming many metal alloys in terms of stiffness and strength-to-weight. Even though it started out as a very expensive material, carbon fiber is much more affordable today due to the increasing demand over the years and refined manufacturing techniques.



Fig.01/08 Charles and Ray Eames deeply explored Glass Reinforced Plastic (GRP) in furniture design.

LIGHT EMITTING DEVICE ● In 1977, the discovery of electrically conductive organic polymers led to significant advancements in the field of electronics, including the development of light-emitting devices or LED – formerly known as light-emitting diode. These tiny light sources enabled surfaces and textiles to be lit and even to form screens, in a wide range of colors. Their high efficiency enabled large architectural surfaces as well as thin reveals to be illuminated, transforming the look of contemporary architecture. Recent examples of material integration include LED woven into a metal fabric, such as in GKD’s MediaMesh®, or set in resin such as in Sensibile’s Lumina®.

COMMITMENT TO SUSTAINABILITY ● From the 1950s to the end of the 20th century, the consumption of finite resources, pollution caused by manufacturing and transportation practices, the amassing of persistent waste in landfills, and the overall negative impact on the environment and diversity of life created a growing awareness that a prevalent sustainable mindset is needed. The first conference on “green goods” was held at the Hague, Netherlands in 1993; one of the first steps for a sustainable and green future. Today sustainable thinking is an integral part of the design process, and many leading manufacturers are committing to sustainable practices;

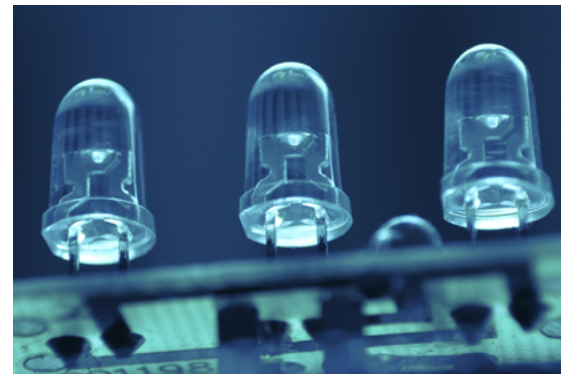

Fig.01/09 Today, Light Emitting Devices (LED) are a common source of artificial illumination.

which is ultimately transforming how materiality is understood and applied.

SMART AND RESPONSIVE ● Today, new materials are continuously being introduced featuring nanotechnology, programmability, light-mapping, phase changing, etc. Designers have more options to explore and are given more capability to increase the quality of life, create unique experiences for users, and ensure sustainability. Many of these materials are in daily use; electrochromic glass can convert from transparent to translucent instantly with the flick of a switch, thermochromic coating on a mug can change appearance when heated by the hot liquid in it, or photochromic lenses develop a dark tint with exposure to UV light. Similar to composites, it is not hard to imagine that smart and responsive materials will be further enmeshed into daily life in the future.



Vid.01/02 Video on improving electro-chromic glass performance.

MATERIAL PERFORMANCE

Material performance refers to various physical and chemical properties that determine the behavior of a material under various conditions. Understanding performance parameters is key for specifying the best material for a particular surface, design detail, or finish. *The performance properties of materials are systematically investigated by the field of **Materials Science**.* A piece of metal feels cold to the touch due to its high thermal conductivity, or the injection molding success of a thermoplastic resin is determined by its melt flow index. Materials science employs an engineering mindset to solve manufacturing issues. On the other hand, an interior architect or designer is more involved with aesthetic impli-

cations, psychological impact, sustainability concerns, maintenance and life cycle costs, and end-of-life processes of materials. Therefore, a basic understanding of the foundational terminology and related performance parameters is important to make sense of materials, but more often than not, designers don't have to understand the exact physics and chemistry behind the parameters.

*A material's performance, visual quality, and workability is determined by the specific arrangement of its **molecular structure**.* For example, steel has a homogeneous distribution (isotropic) and wood has a heterogeneous distribution (orthotropic). Based on its molecular structure, a material can be hard/soft, elastic/stiff, porous/impervious, transparent/opaque, conductive/insulative, flammable/fire retardant etc. In general, a combination of multiple properties determine the performance of a material.

To assess the behavior of a material under stress, it is important to understand the various forces that can act on the material. Compression, tension, and shear are the most prominent three of such forces. **Compression** refers to pushing onto or squeezing the material. On the other hand, **tension** refers to pulling or stretching the material apart. Lastly, **shear** refers to applying opposite forces on the same body.

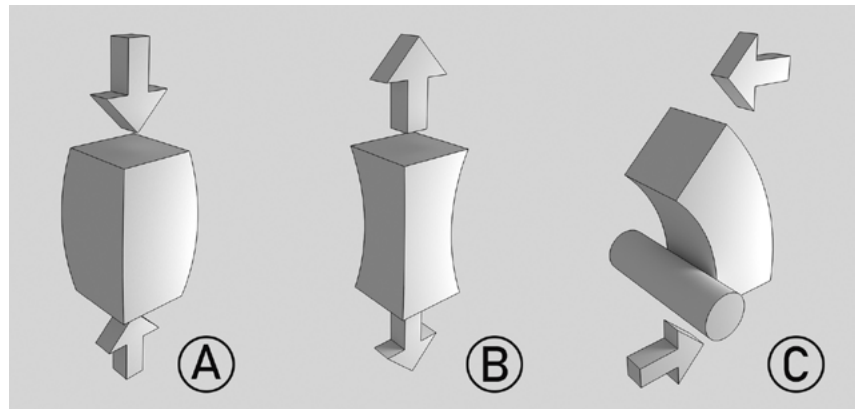

Fig.01/10 Compression (A), tension (B), and shear (C) forces acting on a simple object.

As opposed to isotropic materials such as steel, porcelain, or acrylic, the properties of a wood piece are not homogeneous in all directions, conversely, being an orthotropic material the mechanical properties are distinct and independent on each axis. Imagine a piece of wood with a prominent and fairly parallel grain structure; considering that wood is highly sensitive towards the directionality of the applied force, it can relatively easily split along the grain. Now, compression applied across the grain (tangential) might create failure, as opposed to compression applied along the grain (longitudinal). On the other hand, tension applied along the grain is tolerated much better than across the grain as it would split the material at the weakest grain. Some sources mention up to 20 times the difference in resistance. Lastly, shear strength will be higher against the grain than along the grain. Grain direction is one among many properties when considering the strength of wood, along with wood species, density, drying method, or the presence of knots. **Ductility** is a material's ability to withstand tensile stress. Ductal®, the ultra-high performance concrete (UHPC) manufactured by Knauf is one example used in demanding structural applications. Ductility also determines impact strength in materials, their



Fig.01/11 Concrete mixture poured over rebar lattice.

vid.01/03 Video on the reasoning behind concrete reinforcement.



ability to deflect instantaneous loads.

Materials can display improved performance when they are **combined** to work together. For instance, concrete is a material that performs well under compression but poorly under tension. In order to augment the performance of concrete, a material with high tensile strength is needed and steel possesses the necessary properties. Reinforced concrete is developed with this principle in mind, so as many other composite materials. Aside from acquiring a strength and stability benefit, the specific pH of the concrete wrapping the steel reinforcement keeps it from corroding. Together these materials achieve substantially better performance.

Density is the ratio of a material's mass to its volume. It should be noted that high density does not always mean high stability or durability. For instance, gold has very high density but it is so soft that pure gold can be bent and scratched with bare hands. Low-density materials are

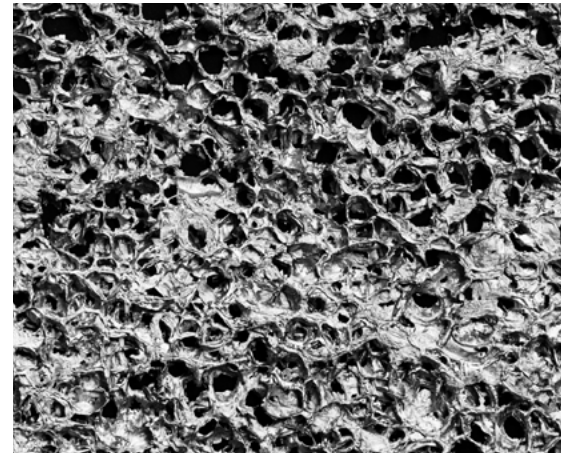

Fig.01/12 Foamed aluminum features tiny gas bubbles.

often ideal for thermal insulation; even some highly conductive metals such as aluminum can be highly insulative when foamed. **R-value** indicates a material's capability for resisting the flow of heat. **Hardness** refers to the ability of the surface of a material to withstand scuffing, scraping, scratching, denting, and various other physical abuse. Porcelain has a higher degree of hardness compared to common ceramic tiles which makes it appropriate for areas with high traffic. **Stability** refers to the ability of a material to maintain its properties and structure in the face of environmental changes, including but not limited to moisture, temperature, or UV exposure. Compared to medium density fiberboard (MDF), chipboard is far less stable as it will quickly deform and deteriorate when exposed to moisture. **Durability** is similar to stability, but focuses on the longevity of resisting change. As an example, introducing fly ash to a concrete mix will increase its durability as well as cold weather resistance, cracking problems, and permeability. **Elasticity** refers to the ability of a material to completely recover from deformations produced by physical exertion after the load is removed. Rubber is highly elastic and resists denting and deforming when heavy equipment is placed or dropped on it, making it a great choice for gym flooring.

Workability refers to a material's tendency to resist being physically shaped and processed, being cut, folded, hammered, drilled, milled, welded, planed, sanded. It is an important concern when specifying materials as it will impact workmanship costs and final product's success. **Malleability** is one aspect of workability that is defined by the material's ability to be permanently and predictably deformed under

compressive stress. For instance, sterling silver is highly malleable, it can be manipulated easily and predictably so that it is commonly used for handmade jewelry. On the other side of the spectrum, glass after it is tempered cannot be drilled or cut as it will simply shatter. Marble is especially fragile along its veins and susceptible to breakage. It is difficult to weld copper as the heat output will also substantially distort the workpiece. Workability is a serious issue for anisotropic and orthotropic materials, those that don't have homogeneous properties on different axes. For instance, cherry wood, despite its desirable grain patterns, exhibits directional changes known as grain reversal, making it difficult to work, plane, and join.

SURFACE ATTRIBUTES

Within an interior space, the user primarily experiences the surface features of materials. Beyond their immediate visual qualities, surfaces can be felt through skin, soak up or exude various odors, absorb or reflect sound in unique ways, determined by their make-up and finish. Surfaces will require cleaning, conditioning, sealing, protection, and maintenance. Most surfaces will weather, wear, abrade, and fade.



vid.01/04 Video on the outcome of drilling tempered glass.



Fig.01/13 Water can easily cause destruction behind wall finishes, without the occupants ever noticing.

*Water is claimed to be the source of all life but when it comes to the construction business it is the source of all **decay and degradation**.*

Moisture needs to be carefully calculated and controlled throughout a building, including within the envelope: the boiling water on a range, a hot shower in a small bathroom, splashes from a powder room sink, leakage from a water tank, the water smeared on baseboards when mopping, or seeping through old grout. After it is absorbed, water will easily diffuse through materials, and vapor in the environment can condense at cold spots, creating opportunity for mold growth.

***Absorption coefficient** is an important property determining the ability of a material to absorb liquids and vapors when it is exposed.* Absorption coefficient has a significant influence on the possible uses of a material and the various ways it can be treated, sealed, and finished. For instance, wood is a porous material with an ability to retain moisture and react by deforming or it can simply rot. Sealing the wood with a coating of varnish would extend the life expectancy of the material significantly. One should also consider that absorption levels substantially differ between wood species. For instance, due to its naturally oily constitution teak repels water and is a popular material for high-end shipbuilding. Untreated fabrics not only absorb vapors, organic compounds, and odor from the environment, they tend to release them back, sometimes over many years. Another important example is granite, the surface of which appears impermeable to the naked eye, however, it harbors microscopic pores and a yearly sealant

vid.01/05 Video on how to seal granite countertops.



application is required to inhibit bacterial growth. For this reason, granite countertops cannot be used in commercial kitchens as they cannot satisfy the National Health and Safety Foundation's NSF/ANSI Standards developed for food contact materials, unlike stainless steel, quartz, and some other resin bonded countertops such as terrazzo. Metals are non-absorptive, however, their surfaces chemically react to the environment often eventuating in tarnishing, staining, oxidation, and corrosion. Therefore, they need to be alloyed with more resistant metals, or a protective surface finish is required; their non-absorptive nature may dictate an alternative paint finish such as powder coating.

WEATHERING AND AGING

Extended exposure to various environmental conditions, such as humidity, pollution, sunlight exposure, abrasive contact, cleaning agents, etc. causes materials to weather and age. Inappropriately specified materials, coupled with poor protection and maintenance practices, can age very quickly and badly. On the other hand, with proper surface treatment and appropriate care they can age in a very desirable manner.

*When specifying materials, the designer should consider how the material will **transform** due to environmental conditions in the next 2, 5, and 10 years from the project completion date.*

***Patina** refers to the transforming surface condition of a material, that develops over time as it is exposed to physical or chemical actors whether through natural or artificial means, until an equilibrium is reached.* Some of these actors are moisture, UV light, caustic or alkaline chemicals, surface abrasion, etc. Patina development is closely tied to the specific environmental conditions, for instance, the same copper roofing can develop a slightly different color and

texture in a seaside city where the air is more acidic and corrosive compared to an industrial inland city where the air is more polluted. Pre-patination and pre-weathering are common among construction materials, enabling visually consistent weathering effects without the time commitment. Nevertheless, the unique visual signature of a building's site cannot be attained through artificial means.

Many materials are **sensitive to daylight**, or sometimes even artificial lights such as Xenon. Light exposure causes materials to deteriorate, some lose color and vibrancy, others lose flexibility, and some simply disintegrate. The effects of UV light on wood components are well known. Wood slowly darkens and grays out as it is exposed to UV light, sometimes creating an uneven and undesirable look if the exposure is irregular. Careful specification, UV inhibiting finishes, a deeper stain finish, or installing low-E glass on openings can help control the effect; simply sanding and refinishing wood after several years of use might be another answer, depending on the species of wood. Other materials such as high-density polyethylene become brittle with extended sunlight exposure and starts to crumble; on the other hand, some plastics, such as acrylic, largely stay unchanged.

Dimensional movement is another significant consideration when specifying materials. **Materials deform over time** as the environmental moisture level changes, building settles, temperature fluctuates, or continuous weight, force, or vibrations are exerted. For instance, expansion joints in cast-in-place concrete finish are utilized to mitigate cracks due to dimensional movement; a shiplap or tongue and groove joint work in a similar way especially useful when a species of wood, highly susceptible to warping, is used, such as Douglas fir before it is stabilized in its environment. **Creep** is the permanent deformation of a material due to the exertion of a constant force over time. If a material is expected to support constant loads over long



Fig.01/14 Every naturally developed patina features a unique look based on its location and surroundings.

periods, the designer should make sure that it is ductile enough and properly supported. One serious issue regarding dimensional movement is the degree of compatibility between different materials that are specified to interface together. **It may be necessary to allow for the relative movement** of different components that are expected to respond to environmental conditions differently. For instance, if relative movement is expected when attaching wood to a metal frame, washers can be utilized to screw the wood piece through larger holes on the metal frame. This will allow for some movement, minimizing the chance of damage over time.

02

PERCEPTION

- *Perception of materiality*
- *Understanding design trends*
- *Historical, cultural, and design context*
- *Concept driven material specification*
- *Visual elements and principles*
- *Balance, dynamism, and composition*
- *Non-visual senses*

Materiality refers to the perception of the quality and state of each material applied to components of a space or a product. **Perception of a material is a complex cognitive process, involving the engagement of multiple senses as well as the mind.** It simultaneously stimulates visual, tactile, auditory, and olfactory senses; colors and texture, being shiny or matte, feeling of cold or warmth, being taut or loose, etc. Furthermore, it also incorporates the end-user's experiences, expectations, preconceptions, upbringing, and culture; it can be highly subjective. For instance, the amount paid for a product affects its self-constructed value, it influences how the quality and refinement of the finish is perceived. A similar bright colored and reflective vinyl finish might be perceived as plasticky on a \$15 skirt, or tasteful and refined on a \$500 one. The success of the end product in terms of material selection depends not simply on finding the material that fits the budget and performance criteria well and has the most aesthetic appeal, the designer has

to anticipate how the material will be perceived by the intended end-user as well.

Individuals develop an understanding of the materials that constitute their environment through visual, tactile, auditory, and olfactory senses. Each sensation shapes their expectations and affects the overall experience of a space, component, or product. For instance, perceiving an oversized puffy pillow will create an expectation of comfort or the view of a brick fireplace will create a sense of hominess, coziness, safety, and relaxation. On the other hand, transparency may create a sense of invasion of privacy, or the reflections suggesting wetness might create discomfort due to an impending accident, or glare from intense reflections will create a more direct and discernible source of disturbance. One would know that velvet will be pleasurable to touch or intuitively understand that the smooth surface of the handrail will be safe to hold on to. Bits sticking out a surface will contribute to the perception of discomfort, or stickiness might evoke a sense of disgust. Wooliness will support a sense of warmth, or steel will feel cold as it quickly drains the heat away from the body. Hearing a lot of reverberation in a space will suggest openness and eeriness, whereas hearing no reverberation will suggest restriction and confinement. A sense of achievement can be instilled with the “new car smell” or the smell of mold & mildew can urge the user to run away.

*Understanding how users perceive materiality with distinct senses bears substantial importance for the designer, so that the designer can **effectively manipulate** how the end-user will experience the design product.*

Exactly where and in what way a material is utilized plays a significant role in how it will be perceived. *User **expectations and preconceptions** play an important role in the perception of*



Fig.02/01 Wool creates an expectation of warmth and in some cases itchiness.

*materiality, shaping the situation into a positive, negative, novel, or bland experience. The reaction of the end-user to a glass floor will be much different than to a glass wall. The same goes for using polished aluminum for a shoe, where a softer material is expected instead of a rigid metal. The designer needs to remember that, for a space that is visited once every while, such as an expensive restaurant or a retail store, a **novel experience** will stay to be novel; and the downsides can be tolerable. But using this novel material in a residential setting might lose its novelty over time, as it will be experienced on a daily basis; the sense of novelty might quickly transform into annoyance.*



Fig.02/02 The glass facades of Farnsworth House have been a major source of privacy related controversy.

Reflecting upon the history of materials can inspire innovative uses and combinations. The designer can foster connections among materials, fabrication, users, and place. For instance, once very demanding wood inlays can be fabricated by precise laser cutting and CNC milling today for a fraction of the cost. Though, the perception of delicacy and lavishness can still be present. Another example can be “béton brut” or raw concrete’s association with the Brutalist movement mindset. Breaking free of any such associations requires innovative thinking. Social and cultural norms are another important component of the overall design context. Different social groups with different cultural idiosyncrasies will perceive materials differently. For instance, Bamboo is a material that has many cultural associations reflecting traditional Chinese values, or a Muslim individual might avoid wearing pigskin leather for religious reasons.



Fig.02/03 Brutalist architecture features substantial amounts of unfinished concrete surfaces.



Vid.02/01 Video on the Barbican and transformation of Brutalist Architecture.

Context is the physical, socio-cultural, or financial conditions and constructs that surround a design problem, affecting how it is perceived and approached. Historical context, cultural context, and environmental context affect how materiality is perceived. Context also includes the clients’ or prospective users’ needs and requirements, building program, ongoing trends and preferences, human factors, sustainable thinking, etc. Furthermore, perception of materials doesn’t occur in isolation, per surface or object. Each material within a space affects the overall context. *When specifying materials, the possible synergy and the overall **combined effect** should be carefully considered.* Imagine a large wooden conference table in an otherwise minimalistic and sterile conference room. It should bring a sense of warmth and a connection to nature to the environment, via an easily perceivable contrast. On the other hand, the same conference table might not work as well in a room with elaborate wooden paneling, even though it has the exact same physical properties. The perception also involves paying attention to not only surface quality but also color scheme and the lighting conditions of the environment. A chrome-plated metal border on a polished granite wall may not create the same impact compared to when it is combined with a vein cut travertine cladding, as the contrast in texture and sheen will help it stand out. It is the overall effect that counts and it requires careful thinking.

*The designer should always ask, “how will this material be perceived **within this context** and what kind of synergy it will create with its adjacent surfaces?”*

Trends are another important notion that influences end-user's perception. *In the context of spatial design, trends can be defined as a specific color, material, or finish inspiring collective attention and desirability for a period, owing to exposure, popularity, or association.* Trends can be relevant for some contexts, such as a trade expo stand or a retail space, whereas in others not so much, such as a government office or a history museum. For some types of materials, such as fabrics and wallcoverings trends are highly relevant. Oftentimes products that were released around the same season seem to resemble each other and companies invest large amounts of money to track and set trends. The designer needs to know about existing trends and forecasts but also needs the skill to manipulate user perception and generate interest. For example, subway tiles are deemed as classic and timeless by some but in a modern interior, they can easily look dated. However, a contemporary re-imagining of a subway tile with an elegant finish might be a good nostalgic touch or a clever throwback/reference.

A recently trendy material, color, and texture can look **distinctly dated** when it goes out of vogue.

A **design concept** is an abstract framework for design development, a tool for outlining design intent, distinguishing a design product from a mere object of function or decoration. A conscious and methodical approach to the material scheme is key for meaningful and impactful



Fig.02/04 The concrete cantilevers in Fallingwater House sets a stark contrast with nature.

design; one area where the design concept will manifest itself. In his 7132 Thermal Baths project, Peter Zumthor's linear use of Vals quartzite and still water creates a sense of serenity and relaxation that is in line with the overall idea of creating a place for respite. Frank Lloyd Wright's choice of concrete in Fallingwater House is not only a novel use of the then untested material, but also a statement to stand out from the surrounding lush natural environment.

Tab.02/01 Examples of translating a concept keyword to design decisions pertaining to materiality.

Concept Keyword	Possible Translation to Materiality
Tension/Release	Contrasting a rigid material, such as marble, with a loose and soft one, such as felt
Growth	Highlighting solid wood with very prominent grain, stained for effect.
Interdependence	Specifying a composite with a transparent matrix, showcasing the reinforcement.
Outreach	Ensuring uninhibited transparency, via the utilization of glass or acrylic.
Anti-Organic	Using molded concrete to produce angular/geometric volumes.

vid.02/02 Video on material use in Peter Zumthor's Therme Vals Spa (enable close captions).

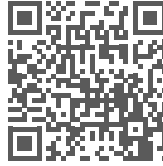

Another important consideration that affects user experience significantly is emotional response and assigned value. The famous adage, “form follows function” is one way to look at the design process. However, *anticipating an **emotional response**, placing an emotional value, building memories and ownership around a product or space can be as important as its functionality.* The end-user doesn't always act on purely logical reasoning on how a design product functions. Most beloved spaces and objects have a story attached to them, and their function may not be a principal consideration. One might remember their underlit attic bedroom fondly because it gave them privacy and shelter during their sensitive teenage years. Linoleum kitchen flooring might be preferred by some demographics due to the associated sense of nostalgia. Custom made brass door handles might be completely

unnecessary in terms of function but it signifies financial achievement and can improve overall user experience and enjoyment.

VISUAL NATURE OF MATERIALS

When perceiving materials, human beings primarily rely on their sense of sight. Within one's field of vision, a material is conveyed first through optical perception followed by other senses. A key component of visual perception is the manner in which light strikes a material's surface and the effect that ensues. The nuances of the visual perception of materials can be described using the following specific terms: color, hue, depth, light transmission, luster, reflection, shade/tone, tint, value, sheen, texture; these constitute a useful vocabulary for professional expression of one's ideas.

*An accurate understanding of what each specific term mean will enable the designer to **communicate ideas** clearly with their peers, providers, contractors, and even clients; minimizing the risk of misunderstandings and mistakes.*



Fig.02/05 The use of leather in high-end car interiors is less about functionality and more about emotional impact.

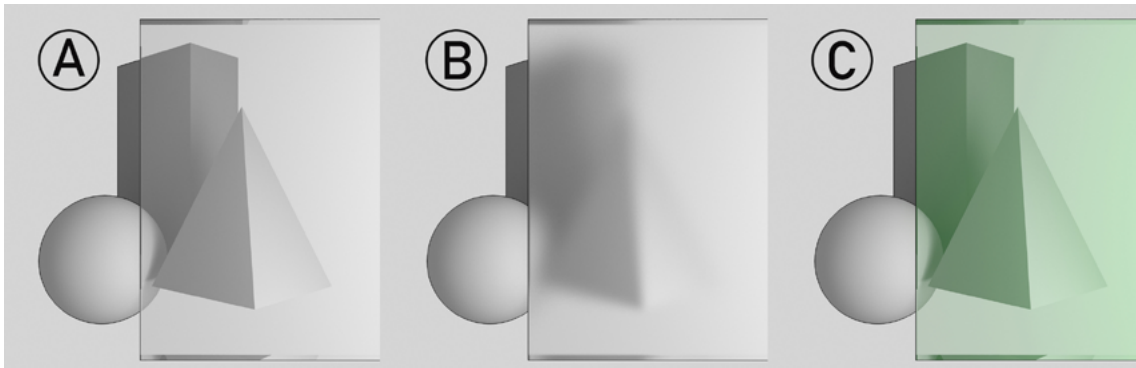

Fig.02/06 Examples of transparent (A), translucent (B), and tinted (C) glass.

LIGHT • Light is the principal requirement for visual perception. The incident light on a surface can be reflected, absorbed, or refracted in various amounts, defining general visual properties of a substance. Based on the proportion and transformation of light passing through the material, or light transmission, a material can be referred to as opaque, translucent, transparent, or tinted. **Opaque** refers to a surface that completely blocks the passage of light. Even though transparent and translucent materials allow light to pass, **transparency** provides a clear view through, whereas **translucent** material diffuses light creating a frosty look. Tinted materials only let certain parts of the color spectrum to pass, creating the transparent or translucent material as well as everything behind it to be perceived as a certain color.

Reflection refers to the unabsorbed returning light wave bounced off a surface. Every surface reflects light to an extent. Even the darkest material, currently Vantablack®, reflects 0.02%. The nature of reflection, whether diffuse or direct, provides valuable clues about surface quality.



Vid.02/03 Video on identifying the effect of luster on various minerals.

For instance, polished steel will reflect light in a more uniform manner whereas brushed or sand-blasted steel finish will in a more diffuse manner. **Luster** refers to the specific way a material reflects light. **Sheen** is luster manifests as shine, glow, or gloss on a surface. The **shade/value** of a surface you perceive depends on the angle of light striking a surface. As the angle becomes more perpendicular the surface will receive and reflect more light. **Shadow** is an area deprived of light due to obstruction and can be perceived as an extension of an object that is casting it.

Vantablack® - Surrey Nanosystems | www.surreynanosystems.com



Fig.02/07 Vantablack® absorbs 99.8% of incoming light, to such an extent that surface detail can be perceived.



Fig.02/08 The glare in this environment is exacerbated by the contrast of the dark material around the windows.

Shadows are instrumental to the perception of the **3-dimensional nature** of a surface.

Exposed to high-intensity light sources, reflective surfaces are prone to generating glare. For instance, polished marble flooring in an atrium would strongly reflect any light source; and any high-intensity source would create glare depending on the angle of the viewer. When openings are considered, if the framing material or surrounding drapery is darker, it might generate glare due to the contrast with outside lighting levels. **Glare** is not only uncomfortable but can be dangerous, requires special attention.

Daylight and artificial light are two broad categories of light that create significantly different visual effects. The diameter of the sun is 109 times of Earth's diameter. As a result, the rays

of sunlight received by earth are parallel and the intensity is fairly uniform over large distances. This affects the nature of daylight shadows. On the other hand, artificial light can be emitted from a point, line, or an area outwards. The shadows are elongated and distorted. Depending on the initial power of the source there will be areas of comparatively more light, and intensity will be lost quickly. Shadows will also be softer, more diffused, they might lack definition. There can be multiple sources of light, which create multiple shadows with multiple intensities.

The designer can **manipulate the spatial experience** through the interaction of light and materials; they can break the monotony and create dynamism, create an ambiance to support the design intent, direct attention with light and define borders, or support wayfinding.

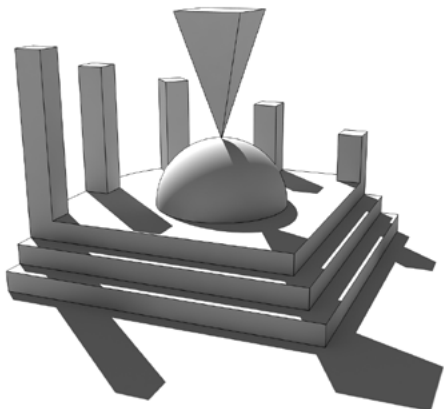

Fig.02/09 Sunlight casts parallel shadows and the light intensity is consistent, it does not fall off.

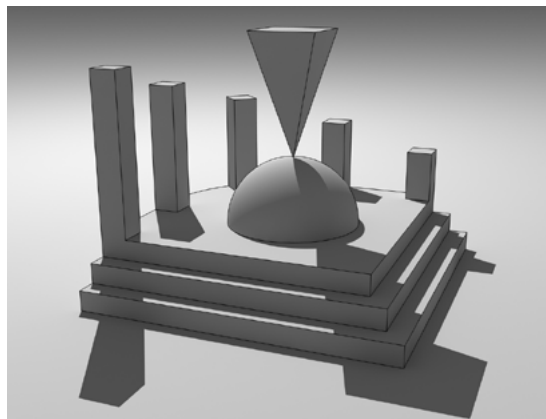

Fig.02/10 Artificial light casts shadows that fan out and the light intensity drops exponentially.

The perception of color enables the viewer to make sense of the intricacies of the three-dimensional environment around them. Wavelength of light reflecting off a surface determines if the particular surface will be perceived as red, green, or violet. This perceived aspect is often referred to as the color or the hue of an object. However, **hue is different from color** as *hue* refers to a overarching category determined by wavelength whereas *color* encompasses several properties including hue as well as saturation, value, etc., referring to the actual combined wavelengths. For example red is hue and pink is the color. In most sources, the primary colors (red, blue, yellow) are referred to as hues, and in others secondary (green, violet, orange) and tertiary colors (blue-green, yellow-green, etc.) are also included. The basic idea of hue is to identify a color family by using a color with no variation in saturation, shade, tint, or value, intensity. There are various terms that define the nuances of color further. **Shade** or *tone* refers to the presence of black in a color or hue. On the other hand, **tint** is the presence of white in a color or a hue. **Value** is the overall degree of lightness and darkness of a hue. **Saturation** refers to the intensity of the hue, or oppositely desaturation is the amount of gray perceived.

vid.02/04 Video interview of Rem Koolhaas on the Melbourne Pavillion and use of light.



Fig.02/11 Hue refers to the broader color category. Here, pink is the color whereas red is the hue.



Fig.02/12 Red, green, and blue pixels light up at different intensities to form the image.

Depending on the medium color, mixes show different characteristics. **Additive color mixing** is combining light sources of different colors and creating a mixture that is moving towards



Fig.02/13 Plastic pellets are one example where subtractive color mixing rules apply.

white. One prominent example that exploits this principle is the pixels on a laptop or smartphone screen; any color is generated by combining red, blue, and green light of different intensities. Understanding how light mixes is important for establishing ambiance and creating effects. On the other end, **subtractive color mixing** is combining dyes, inks, pigments, or colorants to achieve mixtures that are moving towards black, or dark as light is subtracted. It is specially important when considering achieving various colors with plastic pellets or paint.

There are a number of websites and software where you can find custom color schemes. You can also check artworks for inspiration. Designers should use color intentionally: **to establish form, create dynamism, generate interest, and ensure balance**. Controlling the proportions of color in an environment is also as important. The designer should ask which colors are dominating, which colors are supporting. **Limiting the color palette is often good**. The use of color should be deliberate and impactful, rather than turning into background noise and getting lost in the mix. Due to changing trends, certain colors become more popular at certain times. Many paint companies publish color forecasts to report the changing trends.

Color can be used in design for the following



Fig.02/14 Color can be utilized for attracting attention (A), grouping elements (B), indicating meaning (C), enhancing aesthetics (D).

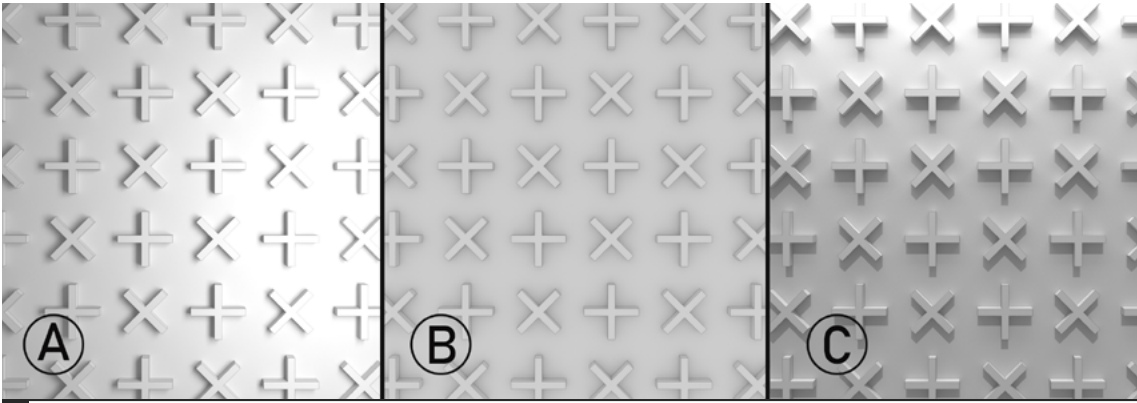

Fig.02/15 Examples of relief receiving light from various angles: sunlight (A), diffuse light (B), wall washer (C).

purposes of **attracting attention, grouping elements to indicate meaning, and enhancing aesthetics**. Color can be utilized to drive the attention of users, but also an excessive use of color would weaken the effect. As a result, other design elements may become the target of attention. The designer can indicate or emphasize a relationship among different design elements. *Meaning of color can be very subjective, where context and nuances are important, and the designer should anticipate the effect.* Earth tones might indicate a sense of permanence, experience, rootedness, or the use of red might introduce a sense of dynamism and excitement. A lack of color can be tied to solemnity and spirituality, or a multiplicity of color ties to a sense of playfulness, youth, and energy.

TEXTURE ● *Texture is a visual construct that has an approximate repetition and a sense of continuity among its parts, even though for some textures distinguishing this exact repeating visual unit might be difficult. Texture gives*

the viewer clues about the nature of a surface and finish, simplifies comprehension of surface topology, enhances spatial perception and sense of depth, introduces variety and interest, and as previously mentioned, it also implies tactility. Texture enables the viewer to identify the nature of a material, if it is soft or hard, slippery or rough, stretched or loose. Furthermore, based on previous experiences it is possible to establish a sense of scale with the use of texture and proportionally relate elements of an environment. Texture can have three-dimensional qualities. **Relief effect is the perceived depth of a materials surface.** Oftentimes the relief effect can be enhanced or dimmed by adjusting the direction of incident light and controlling shadows.

Perception of texture is affected by light intensity and direction, size of the visual units comprising the texture, the contrast between units, the reflectivity of the surface, and the distance of the viewer. Context is key in texture perception. The visual environment surrounding a texture profoundly affects its perception. The term texture should not be mixed with pattern. **Pattern** is very consistent and predictable whereas texture have random variations, appearing more natural in comparison. For example, wallpaper pattern typically refers to a

Link 02/01 [Link to colorpalettes.net](https://colorpalettes.net)
pre-made color schemes.





Fig.02/16 The repeating visual unit of a texture can sometimes be hard to distinguish.

consistent graphic application on the other hand a wallpaper texture refers to a more varied and stochastic visual.

OTHER VISUAL COMPONENTS • Usually, movement in design is an implied component. *The **suggested movement** of surface materials creates dynamism and directs attention.* On the other hand, movement can be literal too. Some materials can move in reaction to wind, for instance, movement of drapery with a slight breeze might enhance the ambiance. Motion can be introduced and controlled through sensors and automation. Movement can also imply the movement of the viewer. A space can be revealed through movement. Distance determines the perception of movement in the fore-, mid-, and background.



Fig.02/18 Rhythm establishes a sense of continuity.



Fig.02/17 The visual unit of a pattern is distinctively repeating and easier to discern

*This effect is called **parallax depth** and it can be used to create depth in space by utilizing varying textures on fore-, mid-, and backgrounds.*

Rhythm is crucial in creating a sense of coherency and grouping elements. Due to the repetition aspect, every texture inherently has an implied rhythm. Rhythm should especially be a consideration when using materials in combination.



vid.02/05 Video on Lotus Wall, a kinetic wall finish responding occupant movement.



Fig.02/19 Symmetry can be a powerful design tool.

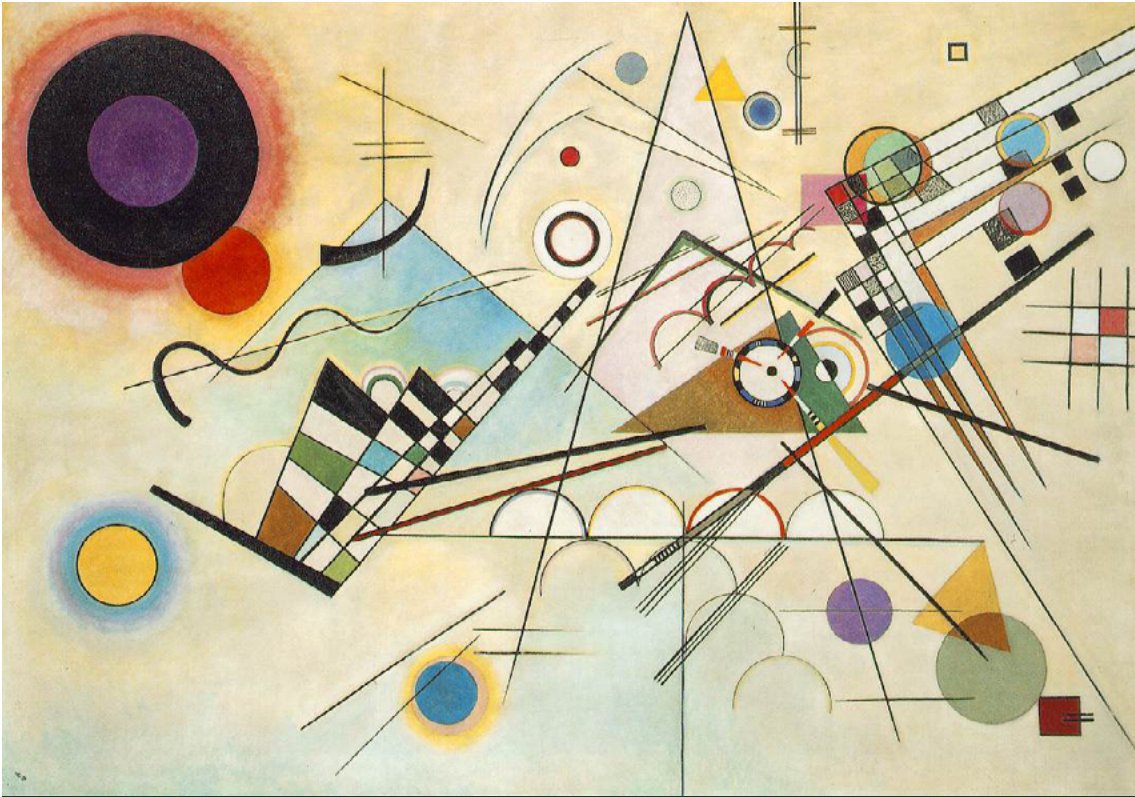

Fig.02/20 Vassily Kandinsky's *Composition 8* is a good example of achieving a complex and dynamic balance.

Monotony is an important concern when working with materials. For example, when finishing large surfaces with a single material. Unless dictated by a strong concept, seeking a sense of balance when specifying materiality and minimizing a sense of monotonicity is key. *In order to **control the build-up of monotony**, it is possible to break down large surfaces to create rhythm and dynamism.* Texture variation can also be utilized, by including different finishes of the same material to break the monotony.

***Symmetry** is often taught as something to stay away from as symmetrical compositions are visually less sophisticated and the repetitive nature often lacks interest.* However, there are times symmetry would come in handy as a conceptual tool. For example, if you intend to

express equality and justice a perfectly symmetrical composition may be the answer.

COMPOSITION ● The design elements and principles covered until now are the foundation for good visual composition practices. Balance is a key aspect of visual composition. *The designer has to be able to use form, materiality, texture, color, light, structure, movement in conjunction with contextual information to create **balanced dynamism**.* However, one should also be careful as too much balance will hinder interest; imbalance sometimes is a good tool for conceptual expression.

NON-VISUAL SENSES

Even though the sense of sight is very important for the perception of materiality, *it is a combination of sight, smell, sound, and touch that fully determines how a material is experienced.* A hierarchy is present on the immediacy of each, and also the ability of how far each sense can reach. Nonetheless, each sensation augments the other and forms a robust perceptual construct; while providing aid when one of them is weak or missing. For instance, under dim light, an individual will rely on the sense of hearing and touch to direct themselves, as the visual stimuli would be unreliable.

Haptic sensations, or sensations related to touch, can be defined broadly as the tactile impression of interacting with materials, products, or finishes. Due to the number of nerve endings and purpose appropriateness, hand and feet are the primary sources of tactile information, even though the whole body contributes to forming the overall sensation. Thermal sense is also part of haptic perception, besides three-dimensionality, roughness, wetness, flexibility, etc.

There are two crucial concepts related to thermal sensation that can help the designer better specify materials: conductivity and emissivity. **Conductivity** in this context is the capability of a material to transfer heat through its body. **Thermal bridges** are the result of a conductive



Fig.02/21 The observer knows the ladle is hot based on their previous observations of glowing hot metals.



Vid.02/06 Video on creating a rough granite finish through flaming.

material creating a path of least resistance for heat transfer. The more efficient a material is in transferring heat from a hot to a cold region, the colder it will feel to the touch. For example, metals feel cold to the touch not because they are actually cold, but because they drain away heat efficiently. In reality, they most likely have reached equilibrium with the environment and at virtually the same temperature as everything else around them.

Emissivity is the ability to radiate thermal energy to the environment. A blackbody is defined as the perfect emitter; on the other hand, a shiny surface will have zero emissivity. Even though a shiny aluminum railing isn't actively sucking heat away from the environment, it has zero emissivity and will almost always be cold to the touch. On the other hand, a dark stained smooth oak railing will feel warmer and inviting. With an understanding of these concepts, the perception of warmth can be manipulated via materiality.

The impression of cold and warmth can even be determined by looking at an image as the viewer already has sensory expectations based on previous experiences.

Materials can be finished in different ways to create varied sensory experiences. Marble can be brushed, chiseled, sanded, or buffed – each method results in a unique haptic feedback. Moreover, utilizing different parts of a material source such as hairs, underfur, or various layers of a hide; or the bark, hartwood, or sapwood of a tree can yield diverse tactile sensations.

03

HEALTH & SAFETY

- *Building codes and standards*
- *Fire safety*
- *The Americans with Disabilities Act*
- *ADA accessibility guidelines*
- *Universal design principles*
- *Indoor air quality (IAQ)*
- *Harmful chemicals*
- *Room acoustics and reverberation*
- *Sound transmission and flanking*

The designer is responsible for ensuring the health, safety, and wellbeing of the occupants, accordingly they should carefully think about the impact of each material and component specified. Building codes and various legislation ensure that the intended design product does not cause any harm; they are enforced through permit processes. However, *building codes are based on minimum acceptable risk*, they can be slow to respond to the newly emerging findings and they don't cover all possible facets of design thinking and realization. The designer should continuously strive to further their knowledge on the possible negative impacts of their design choices.

Building codes outline practices for minimizing risk. **Standards** are a procedure, test method, classification, or requirement that is outlined by an independent organization. Building codes reference standards to be more explicit and accurate. **Rating systems** are voluntary procedures conducted by independent organizations,

culminating in labels that facilitate informed design decisions. **Guidelines** outline the best practices for various aspects of design products.

First published in 2000 as a consolidation of three separate sets of codes, the **International Building Code (IBC)** is developed as a model code by the International Code Council (ICC), referencing a large number of standards and guidelines to explain minimum performance and risk requirements for construction projects. **Model codes** are intended to be adopted by local jurisdictions, either completely or partially, with changes introduced through amendments. For instance, even though IBC Chapter 11 is dedicated to accessibility, it is not uncommon for local jurisdictions to reference Americans with Disabilities Act, Accessibility Guidelines Title III.

The designer has to consider the way a space is used, the possible risks associated with spatial functions and occupant number and behavior. Based on the presence of risks, spaces can be lightly or heavily regulated. **Lightly regulated spaces** are shared by a smaller number of people and the functionality is deemed fairly less risky. One example for a lightly regulated space would be a small coffee joint with less than 10 people present at all moments. On the other end of the spectrum, **heavily regulated spaces** serve occupants in high concentrations including vulnerable individuals, or there are risks associated with hazardous materials or processes. Examples would be restaurant kitchens and hospital operation rooms.

The exact content of regulations that apply to a project is determined by occupancy and construction type, often in proportion to associ-



Fig.03/01 Restaurant kitchens are considered risky environments in terms of fire safety.

ated risks; though, there are various additional conditions and exceptions present. **Occupancy type** is a way to categorize an environment based on the presence of safety risks and combustible content. There are 10 occupancy types and many sub-types. For example, office environments are categorized as business (B), high schools are categorized as educational (E), retail stores are categorized as mercantile (M), if flammable or combustible content is present over a set amount in an environment, it is considered high-hazard (H). Each occupancy type poses requirements and they vary in stringency. When multiple occupancy types need to be considered together, the designer should either adhere to the most stringent type or provide separation with a fire barrier. **Construction type** is a method of categorizing buildings in accordance with their ability to resist fire over a set period. For instance, it would be time-intensive to evacuate a high-rise, or a detention center, therefore the designers involved in the project need to adhere to more stringent safety criteria. At the other end of the spectrum, unprotected wood

vid.03/01 Video on the International Building Code.



frame structure is adequate for a single-family home as a limited number of people will be living in the building, and in case of fire, they can be evacuated fairly quickly. Interior architects and designers often expected to work with an already set construction type, affecting material and finish decisions from the start.

Depending on the code and legislation in question, material selection guidelines include fire resistance, slip resistance, acoustic performance, insulation level, ability to be cleaned or sanitized, visibility, ease of use (particularly in panic situations), and air quality. The codes themselves are freely available, however, they might not be always obvious to the designer. One way to improve understanding of the content is to read illustrated commentaries prepared by the model code publishers.

*It is always a good idea to **get in touch with the local building department** to ask questions, discuss your design decision, and learn about the local amendments and requirements and their interpretation of specific codes, as early as possible,*

The local code limitations have a possibility to alter the design. An example would be, the minimum conditions for when a permit is required. For some local departments this is as soon as you demolish or build a wall, for others it starts with repairing a fence.

STANDARDS

Standards set voluntary guidelines for product specifications, practices, and systems; describe procedures and conditions, overseen by independent organizations, usually signified by certification marks presented on a label or data sheet. The Underwriters Laboratories (UL) tests and certifies a wide range of products, compo-

nents, materials, systems and publishes the materials' performance, identified through various labels in the UL Building Material Directory. Manufacturers can hire accredited third-party testing organizations to conduct these standardized tests. Standards do not have legal standing, they are typically referenced by codes through a combination of publishing organization's acronym, number, and edition.

In the U.S. there is a number of relevant standards organizations that significantly influence the material specification processes for interior architects and designers. American National Standards Institute (ANSI) as well as ASTM International, or formerly American Society for Testing and Materials are major publishers for voluntary standards and guidelines. National Fire Protection Association (NFPA) develops codes and standards aimed at reducing the risk of fire and related hazards. National Sanitation Foundation (NSF) creates and publishes standards for products and services related to public health and safety.

There are separate organizations for flooring material manufacturers such as the Tile Council of North America (TCNA) or the Carpet Rug Institute (CRI). The Consumer Product Safety Commission (CPSC) is an important independent authority that issues safety and performance standards that address product-related illness and injury. For instance, 16 CFR Part 1252 deals with the limits of harmful content in engineered wood products that might be interfaced or used by children. The CPSC website can be searched for unsafe products and recalls.

Link 03/01 Link to the Consumer Product Safety Commission product search site.



FIRE SAFETY

There's a large number for fire safety standards and related tests. Some of these are very significant and can influence design decisions substantially. Moreover, they are also an important part of the tested knowledge base for professional certification exams. **Fire tests** often involve controlled burning of various materials and assemblies within specific environmental conditions, measuring the burning rate, fire spread, heat increase, material loss, smoke production, and toxicity. An **assembly**, or a **construction assembly** in this context, refers to a specific combination of materials serving a singular function. For example, a door assembly can feature multiple materials in combination such as steel frame, wired glazing, or rubber gaskets; it is the combination of all that is tested and rated. Beyond burning characteristics, **smoke generation** is also tested during some fire tests due to the fact that the smoke generated by burning materials is the primary reason for fatalities in fires. For most materials, it can be said that the toxicity of the smoke is relative to the smoke produced during burning. The most important fire tests are described below, understanding what these tests entail should help the designer make sense of codes and eliminate late revisions.

ASTM E119 • This is a collection of test methods for “fire test of building construction and materials”. Floor, wall, and roof assemblies are tested

for their ability to withstand the transmission of heat and hot gases, as well as how much the assembly can maintain its structural integrity when exposed to fire. A pressured hose stream test is also applied on the heated surface at the conclusion, to simulate standard fire response procedures. Assemblies are given an “hour-rating”, designated as 1-, 2-, 3-, 4-hour(s) based on their fire resistance over time. The final hose test is pass/fail.

ASTM E84/NFPA 286 • Being one of the most prominent, this test measures the “surface burning characteristics of building materials”. Also known as the “Steiner Tunnel Test”, the flame resistance and smoke spread characteristics are measured against the performance of fiber cement board (0) and a select grade of red oak (100), and given one of the following ratings: Class A (<25), Class B (25-75), and Class C (>75). A high rating indicates poor performance.

Fire tests can have multiple names, referring to the exact same procedure. This particular test is also known as UL723. It was actually first developed by the Underwriters Laboratories and then adopted by ASTM.

In IBC Section 8, Table 803.11 is based on this particular test and it designates minimum fire resistance characteristics for various types of surface finishes to be utilized within different occupancy groups. There are limited restrictions for trim work such as handrails, door frames, etc., and other decorative details such as wainscoting

Tab.03/01 A section of the IBC Table 803.11 content, Interior Wall and Ceiling Finish Requirements by Occupancy.

Occupancy Type	Sprinklered			Non-sprinklered		
	Interior exit stairways and ramps, exit passageways	Corridors and enclosure for exit access stairways and ramps	Rooms and enclosed spaces	Interior exit stairways and ramps, exit passageways	Corridors and enclosure for exit access stairways and ramps	Rooms and enclosed spaces
Movie Theaters (A-1), Restaurants (A-2)	Class B	Class B	Class C	Class A	Class A	Class B
Business (B), Educational (E), Mercantile (M), and Hotels (R-1)	Class B	Class B	Class C	Class A	Class A	Class C
Hospitals (I-2)	Class B	Class B	Class B	Class A	Class A	Class B
Long-Term Care Facilities (R-3)	Class C	Class C	Class C	Class C	Class C	Class C



Fig.03/02 Fire sprinklers provide significant amount of protection, at a relatively reasonable cost. Especially for new construction, while lowering the fire resistance requirements for materials and assemblies.

or suspended combustible fabric when certain conditions are met.

*Almost always, automated sprinklered environments are subject to **less stringent conditions** compared to non-sprinklered environments. Typically, the resistance requirements are lowered by one hour in sprinklered environments.*

NFPA 265 • Widely known as the “room corner test”, devised for “evaluating room fire growth contribution of textile or expanded vinyl wall coverings on full height panels and walls”. In this test, the fire growth contribution, smoke release, and the potential of flashover of textile or vinyl wall finish are measured in a full-scale mock-up. **Flashover**, is a phenomenon that occurs when the flames reach a certain temperature intensity, known as the flashpoint, an autoignition temperature for surrounding materials. It is approximately 1100°F, a temperature at which

the flames spread rapidly across large gaps. This standard is different from NFPA 286, in the sense that it is limited to vertical surfaces, and the test is conducted in a vertical setup.

NFPA 253/ASTM E648 • Known as the “radiant panel test”, measures the “critical radiant flux for floor covering systems using a radiant heat energy source”, or in other words the fire resistance of horizontally-mounted floor covering systems, such as carpets, resilient floors, etc. Materials are given a Class I rating if they have higher resistance; or a Class II if they have lesser fire resistance, based on their performance characteristics. In sprinklered buildings, Class II materials can be allowed where Class I materials were originally required.

ASTM D2859 • Also known as the “methenamine pill test”, measures the “Ignition Characteristics of Textile Floor Covering Materials”, specifically carpet and rugs. After the test sample is placed on a horizontal plane, a methenamine pill is ignited and placed on the material, simulating

vid.03/02 Video of fire testing at the Underwriters Laboratory.



vid.03/03 Video of a flashpoint demonstration from 1948.



lit cigarette contact. The charred portion of the sample, at any point, should not extend to 1" from the edge of an 8" steel circle frame the center of which coincides with the pill's location. It is a pass/fail test. All carpets and rugs sold in the US should comply with this standard.

NFPA 701 • Also known as the "vertical ignition test", this test measures the "flame propagation of textiles and films" or in other words inherent flame resistance for drapery fabrics. Applies to all vertical window treatment components including shades, curtains, table linens, etc. as well as vinyl-coated fabrics such as blackout linings. It is a pass/fail test. The fabric is exposed to flame for 12 seconds and the burning characteristics are noted.

CAL TB, which stands for California Technical Bulletin, is a series of technical standards adopted by the state of California. The content is not always related to fire safety, however, the following CAL TB items related to furniture flammability have been adopted nationwide.

CAL TB 116/NFPA261 • This test measures the "flame retardance of upholstered furniture". This test measures cigarette ignition resistance, fire propagation, and an overall flammability risk. The test is applied to upholstered furniture mock-ups and actual lit cigarettes are used.

CAL TB 117/NFPA 260 • Also known as the "cigarette test", measures the "flame retardance of upholstered furniture". A complete mock-up is tested. The whole furniture including the filling materials such as polyurethane foam is expected to be smolder resistant. The added flame retardant chemicals are expected to be disclosed on the product label.

CAL TB 133/NFPA266 • This test measures the "flammability of public seating", furniture to be used in public spaces that are expected to be occupied by ten or more people. In a full-scale mock-up furniture heat release, smoke density, weight loss, CO emission are measured.



Fig.03/03 Higher fire resistance and smoke spread ratings should be considered for hard to evacuate environments.

ACCESSIBILITY AND UNIVERSAL DESIGN

Accessibility dictates that every individual whether they have any disabilities or not, should be able to access all key functions and amenities in a space without any obstruction or barriers; at the very least an equivalent experience should be provided as an accessible option. For instance, there should be an accessible stall in every public restroom, regardless of location. In a privately own café serving the public, having a reading nook that is only accessible with a stair with no equivalent accessible experience present would be subject to a class-action lawsuit. One such recent lawsuit is filed against the Hunters Point Library, designed by Steven Holl Architects.

*One important thing to consider about accessibility is that, **it is not only about wheelchair users.** According to the US Census Bureau, 73% of people who live with a severe disability do not use a wheelchair.*

The spaces should be more accommodating to other individuals with disabilities as well, such as using high contrast signage, or under-stair barriers for the visually impaired, or installing



vid.03/04 Video on ADA compliant bar design.

door beacon with LED light or visual/audio smoke detectors are for the hearing impaired.

The accessible design guidelines are outlined by the **Americans with Disabilities Act (ADA)**. ADA Accessibility Guidelines (ADAAG) is not a code or standard, but a piece of civil rights legislation enforced at the federal level and at the local level through enactment. *ADA not only addresses federal, state, or local government facilities, but also **privately owned and operated** facilities, basically any accommodation open to public use is regulated.* Same ADA guidelines prevail across the nation, regardless of jurisdiction. The International Building Code (IBC) Chapter 11 contains codes regarding accessibility issues, however, it is not uncommon that local jurisdictions amend the model code and use ADA Title III instead.

The earliest precursor to the ADA Accessibility Guidelines is the **Architectural Barriers Act (ABA)**, of 1968. It was apparent that the infrastructure was quickly becoming an obstacle for the members of the society with physical limitations to be productive and function like everyone

Tab.03/02 Several material specification requirements as outlined in ADAAG.

(1) Flooring materials should be securely fixed, provide smooth transitions without any abrupt level changes.

(2) Slip resistance should exceed a dynamic coefficient of friction (DCOF) greater than 0.45.

(3) changes in height $\frac{1}{4}$ inch or less are permitted, changes up to $\frac{1}{2}$ inch should be beveled with a ratio of 1:2, and changes greater than $\frac{1}{2}$ inch should be ramped.

(4) Carpet pile height cannot exceed $\frac{1}{2}$ inch and should be securely attached and shall have a firm backing or padding.



Fig.03/04 ADA was introduced to the congress in 1988 and signed in 1990 by President George H. Bush.

else. ABA was fairly limited and only applied to facilities that received funds from the federal government, falling short of being truly inclusive. Another important iteration trying to ensure accessibility is the renowned Section 504 of the 1973 Rehabilitation Act, which later become the ADA Accessibility Guidelines through ongoing development, after the long and painful labor of the Disability Rights Movement. Today, the Architectural and Transportation Barriers Compliance Board is the independent agency responsible for regulating accessibility issues in the United States, including but not limited to the issues regarding the built environment. In residential context, *accessible housing requirements were addressed in the **Fair Housing Accessibility***

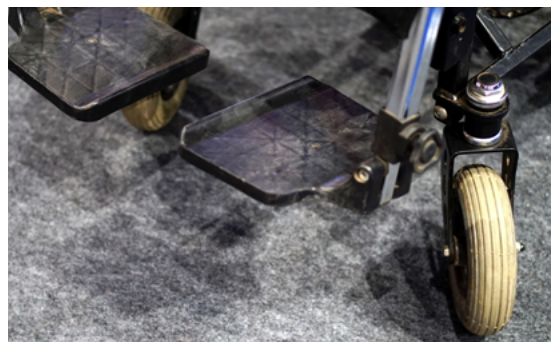

Fig.03/05 ADA accessibility guidelines require carpet pile depth of to be less than 1/2".

Guidelines, which cover accessibility issues pertaining to multi-family housing, clustered dwellings, and separate buildings with common use spaces.

The designer is not a proper user archetype; a vast number of human sizes, shapes, and capabilities, including the children, elderly, people who are pregnant or with temporary disabilities, etc., should always be considered. **Universal design**, is a holistic approach that addresses the broadest spectrum of human needs, promoting equitable access and engagement for all individuals. The term universal design was coined by Ron Mace in 1985. **Human factors** is an area of study that involves collecting and analyzing scientific data on the interaction between the human body and the designed objects and environments, with regard to performing a task.

Universal design is not enforced by any government body, but it is more of a mindset to improve the quality of life of the users and occupants. Following the universal design principles not only renders spaces and products more accessible for people with limited physical capabilities, but it will make it more convenient for the able-bodied individuals as well; oftentimes addressing the problems that caused difficulties

vid.03/05 Video on the principles of universal design.

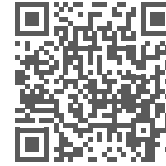

or inconveniences, forcing the designers to think more creatively. Universal design principles are as follows: (1) equitable use, (2) perceptible information, (3) flexibility, (4) tolerance of error, (5) simple and intuitive use, and (6) low physical effort, (7) size and space for approach and use.

PRINCIPLE 1: EQUITABLE USE • This principle recommends providing the same means and provisions for all users, regardless of their abilities, or disabilities. These should not seem like an afterthought, reluctant, poorly integrated, or open to ridicule. Designers should avoid segregation or stigmatizing users. For instance, the use of stair-lifts in the home is being seen as a sign of frailty and incapacity, despite their contribution to the quality of life. There is a need to consider not only instantly recognizable disabilities like wheelchair use, but also parents with strollers, elderly with walkers, or people with temporary injuries needing the use of a crutch.



Fig.03/06 Public stairlifts are dreaded by some wheelchair users due to perceived stigma.



Fig.03/07 Japanese santoku knives feature a single edge and can only be utilized by right-handed chefs.

PRINCIPLE 2: FLEXIBILITY IN USE • Users can have different abilities, body types, anthropometric features, habits, or preferences. It is often a very bad idea for a designer to design based on their own features and preferences. *A product that is adjustable or responds to the needs of multiple groups with **differing features and preferences** is good design.* Even though left-handedness is not considered a disability, cameras, chef knives, power tools, or musical instruments designed for right-hand use make it clear that a more inclusive design outlook should be incorporated.

PRINCIPLE 3: SIMPLE AND INTUITIVE USE • It is bad practice to assume a range of users will all meet predetermined, experience, knowledge, skill, and attention requirements. It is best to simplify interfaces, make sure the use is clear, intuitive, and consistent with the user's previous experiences and expectations. For instance, there's a possibility that users might be illiterate, or wouldn't know the native language at all. By relying on written explanations, such users would be excluded.

Complex design does not mean good design, it is often much harder to create something simple, intuitive, and efficient.

PRINCIPLE 4: PERCEPTIBLE INFORMATION • Using **multiple modes of communication** such as pictorial information accompanied with tactile and verbal is preferable as it is more inclusive. The designer should think about the possibility of various sensory limitations, such as limited vision, hearing, etc. Not every individual has the same visual acuity, therefore high contrast, sizable fonts, legible typefaces are all possible considerations. The instructions, directions, or essential information should be easily distinguishable and placed in an obvious location. The designer should not assume that the user will be able to locate it, simply because they can.

PRINCIPLE 5: TOLERANCE FOR ERROR • All users won't have the same level of attention, hand-eye coordination, or manual skill to operate and interact with a design product, meaning that there will be accidental or unintended actions and *how the designer accommodates the users, minimizing any safety hazards, isolating, or shielding them, marking them clearly and incorporating **fail-safe features**, is important.* For instance, a metal grill on a dense walkway might be extremely hazardous for women walking in high heels, anybody with lowered attention due to being preoccupied may experience an accident.

PRINCIPLE 6: LOW PHYSICAL EFFORT • *An aged body has a different response to fatigue than a younger body.* The design should be operated comfortably from a neutral body position without straining the body, overreaching, and overexerting. Repetitive and sustained effort should be avoided. Softer surfaces are easier on joints and easier to walk and stand on. But it also has to



Fig.03/08 An example of user tolerance, the typical electrical outlet features one slit slightly longer than the other, so the plug is inserted correctly every time.

be flat and level. Trims, details, joints, etc. are obstructions that require raising the legs higher. Another example, it might be harder to control a chair with casters on a deep pile carpet than a wood floor, so material choices should be considered accordingly.

PRINCIPLE 7: SIZE AND SPACE FOR APPROACH AND USE • The designer should consider that users with variance in abilities and anthropometric features, or users relying on various devices to aid their mobility, and the people accompanying them, as well as parents operating strollers or carrying children will require more space to comfortably utilize an environment. *People can have different heights or sizes, or they can be in a standing or seated position within a space, and the **visibility and usability** of spatial elements should be planned accordingly.* A child's features and abilities are quite different from an adult's.

INDOOR AIR QUALITY (IAQ)

People spend the majority of their time indoors, according to some sources up to 90%. Even though most of the interior environments have an influx of outdoor air either supplied from natural or mechanical ventilation, they are fairly confined and particles can linger for extended periods. *The amount of air pollutants is reported to be between 2 to 100 times higher within indoor spaces.*

*Most **materials engage with their immediate environment** either by emitting or absorbing and then re-emitting pollutants; this is primarily determined by their ingredients, make-up, processing, and finish, degrading the overall indoor air quality.* Designers should be careful when specifying materials that can potentially contribute to indoor air pollution. The American Society of Heating, Refrigerating, and Air-Conditioning Engineers (ASHRAE) defines acceptable indoor air quality as “air in which there are no known contaminants at harmful concentrations as determined by cognizant authorities and



Fig.03/09 A simple particulate meter for residential use.

within which 80% or more people exposed do not express dissatisfaction.” The potential of toxic emissions from each material, product, and equipment to be specified should be carefully considered. This goes beyond during and immediately after installation, but also during extended periods of exposure to occupants. The designer can always reference product rating systems, tests, and classifications such as flammability, and acoustic or thermal performance values. A **material safety data sheet (MSDS)** is a report containing information on the composition and ingredients of a material as well as potential health, fire, chemical reactivity, and environmental pollution hazards, first aid and storage measures. Designers also need to outline appropriate cleaning and maintenance protocols as well as periodic treatment and ventilation needs. A material might be considered safe with regular ventilation of the environment, however, toxicity can quickly build up if the user neglects ventilation over an extended period.

Environmental Protection Agency (EPA), is an independent executive agency functioning at the US federal level, featuring multiple programs

Link 03/02 [Link to Corian material safety data sheet \(MSDS\).](#)



related to health, safety, welfare, and environmental issues surrounding the limited and broader impact of toxic substances, pollutants, and industrial practices, in addition to water and air quality. **Sick Building Syndrome** can result from the buildup toxic chemicals in the environment, typically off-gassed by the materials in the environment. As they spend time in the building, the occupants start suffering health problems such as coughing, fevers, and chills, as well as an overall lack of comfort. However, no specific cause for illness can be identified. **Building-Related Illness (BRI)** is a similar condition, however, the symptoms are directly attributable to building, according to the EPA.

Volatile Organic Compounds (VOCs) are toxic chemical gases that evaporate at room temperature and cause short- and long-term adverse health effects for occupants. Plastics and products containing plastic elements such as particle board, plywood, varnishes, laminates, paints, synthetic fibers are all typical emitters. VOCs contain at least one carbon atom, thus the identifier “organic”. Even though some VOCs feature sharp odors, others don’t and require specialized equipment to detect. Hence for VOCs, **a lack of smell does not assure safety.**

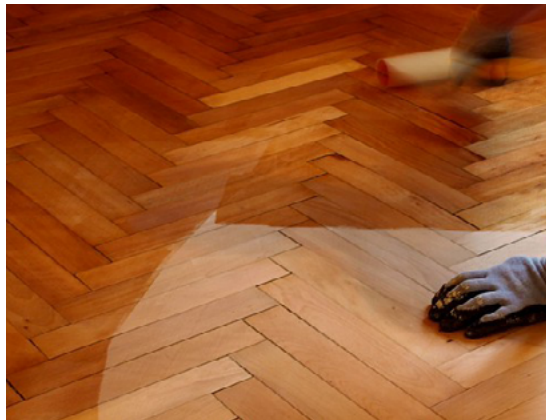

Fig.03/10 Polyurethane topcoat emits VOCs intensely for 4 days, and with decreasing intensity for up to 30 days.

*The period following the installation/application of a material is the most critical for VOC emissions. **Adequate time for off-gassing and proper ventilation** should be allowed before occupancy.*

It is also possible for multiple VOCs to react to or interact with existing materials in the environment and create further health detriment. VOCs can easily permeate absorptive materials such as carpeting, acoustic panels, drywall, unfinished wood, etc. They remain absorbed for months, even years; being slowly re-released to the surrounding environment. Depending on the length of exposure, VOCs impact on health can be serious, and in some conditions, including severe allergic reactions, they can become a significant health detriment. High-Efficiency Particulate Air (HEPA) filters can improve overall air quality in a space but cannot trap VOCs, which are typically around PM2.5 and PM10, too fine to be filtered.

*Wrong material specifications and poor maintenance practices can cause microbial contaminations such as **mold and mildew**, which are important sources of VOCs and they are capable of deteriorating indoor air quality significantly.*



Fig.03/11 Black mold can be fairly inconspicuous sometimes appearing as dirt or stain.



Fig.03/12 Before the devastating health impact was known, asbestos was used everywhere, even as fake snow in movies.

Mold can grow hidden behind walls, ceilings, and even underneath the flooring, as long as there's a moisture build-up. Good amount of ventilation, preferably exhausting directly to the outside, use of vapor retarders on the exterior walls, eradication of thermal bridges or dew points, routine dehumidification, as well as minimizing exposure to known mold food sources are important for prevention. The food sources include materials with cellulose content such as wood, paper facings, and even organic leftovers such as skin cells or uncleaned human food.

HARMFUL CHEMICALS

ASBESTOS ● Asbestos is a highly carcinogenic mineral that was, up until the 1980s, regarded as a highly useful material and utilized in buildings as thermal insulation, for fireproofing, or indirectly as part of other products, such as

filler for vinyl composite tiles. The presence of asbestos fibers in older buildings is not unusual, though these are largely undisturbed and sealed behind walls, ceilings, etc. Inhaling asbestos fibers is highly dangerous. The asbestos fibers lodged in lung tissue can cause inflammation, a condition known as asbestosis, that can develop into a number of deadly complications, most prominently lung cancer.

There are two categories of asbestos: friable and bonded. **Friability** means a tendency to break down, crumble, and chip; particles that are easily disturbed, get loose, and become airborne. This type of asbestos is highly dangerous and when exposed, has to be immediately dealt with. **Bonded** type involves asbestos being used as reinforcement or filler within another material, such as the previously mentioned vinyl composite tiles or asbestos cement roof tiles.



Fig.03/13 Lead advertisement from 1939, praising the weather resistance and durability enhancements.

These may not be as risky but in time fibers can get loose and airborne due to weathering.

Asbestos can be released to the environment through careless removal or damaging of components in buildings constructed before and during the 1980s.

During renovation or demolition, possibility of asbestos presence requires special attention. The Asbestos Hazard Emergency Response Act (AHERA) of 1986 outlines the inspection, identification, and removal processes. The removal and mitigation of asbestos and many other hazardous materials are regulated by Environmental Protection Agency (EPA) and the Occupational Safety and Health Administration (OSHA). The **removal of asbestos** can only be performed by certified asbestos abatement contractors, a process outlined by the EPA. The department of health in every state often publishes the information of certified professionals.

LEAD • Lead is a highly malleable metal with a very low melting point. Before its adverse effects on health were known, it was referred to as the “miracle metal” and was even used as a food additive and make-up component. Lead was commonly used in plumbing due to high malleability and low melting point, before it was replaced by copper, steel, and eventually plastic. The word plumbing comes from the Latin word for Lead, which is Plumbum (Symbol – Pb). Today, it is still possible to find lead pipes in city water service line connections of older buildings. **Along with other heavy metals** such as arsenic, cadmium, mercury, and hexavalent chromium, lead has been identified as a carcinogen, a poisonous

neurotoxin, and an endocrine disruptor. Lead causes serious and well-documented developmental problems. All heavy metals are harder to break down and destroy, which is true for lead too. They are very persistent, accumulate in the environment as well as in animals, move up the food chain, or stay within recycled materials.

Lead was commonly used as a paint additive, it helped stabilize the paint, increased durability and moisture resistance. **Lead-based paint** was present in three-quarters of U.S. homes built prior to 1978. Over the years the paint in older homes has been painted over or covered with wallpaper and buried. Any demolition process, or even sanding down a substrate can disturb the lead underneath and release lead dust that can be inhaled or ingested. *Therefore, the identification, removal, or sealing of old lead paint must be performed by specialized professionals in an approved manner.* Lead plumbing requires urgent and careful removal as well. The EPA has established a **Lead Renovation, Repair, and Painting Rule (RRP)** requiring the contractors that might disturb lead-based paint in homes,



vid.03/06 Video on asbestos removal.

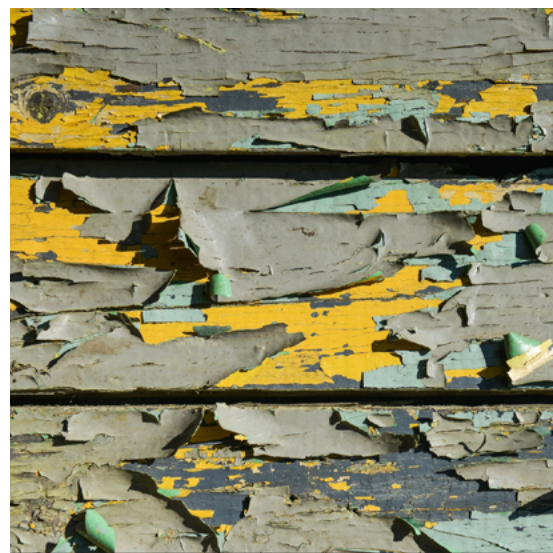

Fig.03/14 Flaking lead paint particles create serious health risks.

child-care facilities, and pre-schools built before 1978 to be certified by EPA.

FORMALDEHYDE ● Formaldehyde-based resins such as melamine-, phenolic-, and urea-formaldehyde are among the oldest synthesized resins, known since 1855. Urea-formaldehyde is highly common in building products. Urea-formaldehyde is the binding resin in many engineered wood products such as hardwood plywood, medium density fiberboard (MDF), and particleboard. Formaldehyde is also found in adhesives, sealants, laminates, insulation, and coating products, like lacquers, paints, and varnishes.

Labeled as a hazardous air pollutant by EPA, formaldehyde is a **serious irritant** especially for sensitive individuals with allergies and asthma, a **known carcinogen**, have developmental toxicity effects. Permissible exposure limits have been outlined by the Occupational Safety and Health Administration (OSHA). The California Air Resources Board also published a standard regulating the formaldehyde emissions from wood products. Furthermore, the emission levels of wood products such as plywood and particle



Fig.03/15 Formaldehyde is utilized as the binding resin matrix in most particleboard manufacturing.

board have been regulated by the EPA since December 12, 2016. Phenol-Formaldehyde is taking over urea-formaldehyde use in some industries due to significantly lower emissions.

When products with formaldehyde must be used, the material must be sealed properly and the environment should be well ventilated before occupancy, until VOC release is significantly lowered. However, this can take around a month, and up to 2 years.

*Designers should keep in mind that **higher temperatures and humidity** cause higher VOC emissions.*

BISPHENOL A & PHTHALATES ● **Bisphenol A**, also known as BPA, is a chemical that is an additive in the manufacturing of a variety of plastics; commonly used in the polymerization of polycarbonate (PC) and epoxy resins, but also found in many other materials such as quartz and solid surface countertops, paints, and plastic laminates. Based on FDA reports, BPA may be tolerable in lower concentrations for adults. However, the research has been revealing BPAs negative impact on health including permanent hormonal development problems observed in infants or pregnant individuals who were exposed to the chemical. Also, links have been found with cardiovascular problems. Currently, food packaging appears to be one of the main sources of exposure. Designers should look for the presence of BPA when specifying materials and try to gravitate towards BPA-free alternatives, especially when food contact is expected.

Another plastic additive with associated health risks is Phthalates. **Phthalates** are very common in plastics manufacturing as they are used to give products various desirable properties. Especially found in Vinyl derivatives, in order to increase flexibility and strength of the material as the actual plastic is hard and brittle. Since PVC resin is typically not very tightly bound and

stable, it deteriorates over time and phthalates tend to seep to the outer perimeter of the material. Phthalates can solve into the water when in contact (leaching), evaporate, or if abraded can hold onto dust particles. *It is possible to **inhale** the chemical or **absorb** it through skin contact while walking over improperly treated vinyl products.* Research have found phthalates to affect the endocrine system, specifically sex hormone levels. They are especially impactful during pregnancy causing permanent development problems. Designers should try and avoid materials with phthalate content as much as possible.

CHLORINE ● Mainly known as a common household cleaner, chlorine is also associated with vinyl products, specifically with Polyvinyl Chloride (PVC). Chlorine is produced through the electrolysis of saltwater and combined with ethylene, which is then converted to an unstable, highly flammable, and carcinogenic intermediate building block, which is polymerized to create PVC resin. *When chlorine is processed or combusted **dioxin** is generated, which has severe health implications and downright poisonous when inhaled.* Dioxins are a family of persistent and bioaccumulative environmental pollutants with severe health implications for humans. Chlorine is also persistent in the environment and does not break down, tends to move up the food chain.

In addition to chlorine output, PVC manufacturing also makes use of the previously mentioned phthalates to increase flexibility and attain various useful properties. However, these are unbound to the original polymer and tend to move towards the surface and leach, vaporize, or abrade into the surrounding environment. The polymerization of Vinyl is not perfect and VC monomer might stay within the plastic and migrate to the surface over time as well. While burning, PVC is capable of releasing highly toxic Hydrogen Chloride (HCl) and Chlorine gases as a result of thermal decomposition.

Specifying non-chlorinated vinyl alternatives

via.03/07 Video on chlorine and chlorine exposure.



are safer for human health and minimize environmental impact. Some of these alternatives are Polyethylene Vinyl Acetate (PEVA), Polyvinyl Alcohol (PVA), Polyvinyl Ethylene (PVE), as well as Polyurethane (PU), and cross-linked polyethylene (PEX). However, these alternatives can have their own limitations and disadvantages, a chief one being their price point.

HALOGENATED FLAME RETARDANTS ● *Halogenated flame retardants are products used to treat various materials for fire resistance; either **as an additive or as part of the coating**, in order to prevent burning and development of fire.* These products include insulation, carpeting, gypsum boards, furniture, and especially polyurethane (PU) foam cushioning as the entire furniture construction is expected to resist fire. In additive form, unless chemically bonded to the polymers. These chemicals can migrate outward and be released into the surrounding environment.

Health problems include delayed development in infants and children, immune system, and thyroid function disruption. They are persistent



Fig.03/16 Office smoking is one reason why flame retardancy rules are so stringent.

and bioaccumulative, won't break down. It is better to avoid these chemicals, especially where exposure to infants and children, or pregnant individuals is a possibility. These materials are very helpful in saving lives and due to stringent fire safety regulations, they become ubiquitous over the course of the last 50 years before their health impact is completely understood. There are safer alternatives such as organophosphate group retardants.

ROOM ACOUSTICS

In addition to its shape, the acoustical behavior and performance of a space is largely influenced by material specifications for each surface. Beyond the simple specification of materials, how they are layered, connected, mounted, suspended, treated, and finished determine their overall acoustic performance. *The acoustics of a space is highly important, a good acoustic environment helps manage stress levels, contribute to wellbeing, improve productivity, and increase overall comfort thereby **justifying the additional investment.***

The first step in specifying materials that would improve a space acoustically, is understanding the basics of how sound behaves. *Sound can be imagined as **variation of pressure or vibra-***

tions on the transmitting material, such as air. The sound we hear is made up of a combination of overtones, or partials, of different amplitudes spread over a large frequency range including bass, mid-range, treble; ranging from 20Hz to 20KHz. This is based on the number of vibration cycles each second. Unless it is a simple sine wave, *the frequency content of any sound wave is diverse, heterogeneous, and transforms over time.* A typical female voice will contain 250Hz to 6KHz content peaking at 2.5KHz, the sound of thunderclap peaking at 100Hz and diminishing in upper frequencies based on distance, or a contemporary music recording utilizing the entirety of the audible spectrum balanced according to the genre and the artist's style.

Sound diffusion refers to the way sound energy disperses throughout an environment. *The **different frequencies of the spectrum behave differently.** Low-frequency sounds behave more like waves and higher-frequencies more like rays.* Low-frequency sounds can travel farther and around objects. or high-frequency sounds are more easily directed and absorbed. Curved and angled surfaces can be used to direct sound. Irregular reliefs or textured surfaces can be used to disperse sound throughout a space, minimizing direct, harsh reflections, and echo-y-ness. Low frequencies don't reflect off of

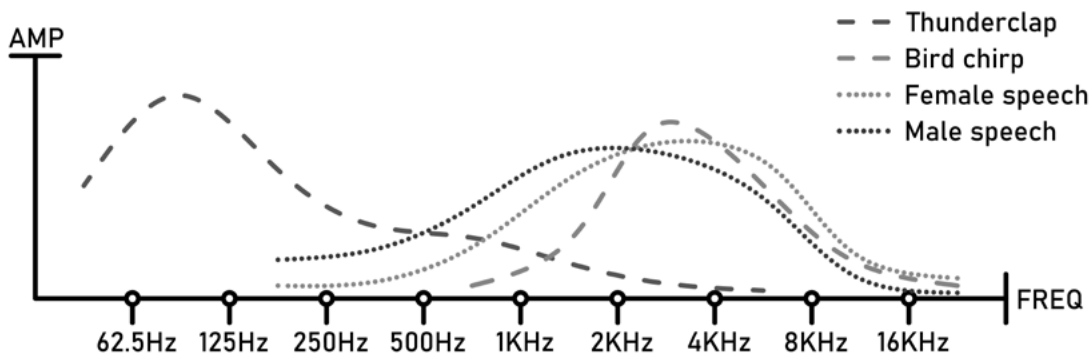

Fig.03/17 Frequency distribution of various sounds.

smaller surfaces, so larger protrusions or details like coffered ceilings are needed for redirection. Sound diffusion is less significant in smaller rooms as space is needed for sound to diffuse.

*Not to be confused with echoes, **reverberation** refers to the persistence of sound reflections in a space after the sound source stops.* Reverberation establishes a sense of space, for instance, a smaller room sounds confined or a large concert hall sounds roomy. Relatively high reverberance is desirable in live music venues as there's added fullness to the sound, however, this will negatively impact the clarity of transients which are key to **speech intelligibility**, which can be defined as the level of clarity in the communication of speech in a given environment. Comprehension of speech is a very complex process and **transients**, a distinct short burst of energy at the beginning of a sound, has a very important role in this process. Keeping the transients above the ambient noise levels, and preventing smearing, or overlapping of transients as a result of direct reflections are key to attaining speech intelligibility. So, in spaces where understanding speech is important, such as classrooms, offices, meeting or consultation rooms, lecture halls, or even theaters, **lowering reverberation levels**, especially between the 1KHz -4KHz range would be



Fig.03/18 Curved wood paneling in this concert hall ceiling is used to direct and diffuse the sound.



vid.03/08 Video on the effects of long reverberation time.

desirable. For some rooms, the ability to modify the reverberation time for specific function may be relevant, such as a concert hall being used for a string quartet concert, for a lecture one day later, and for a rock concert one day after that.

Too much reverberance is a symptom of not enough sound absorption, exacerbated in larger volumes, resulting in a cave-like ambiance. Increasing the number of absorptive surfaces by using carpets, plump furniture, acoustical floating slats, or batting in the plenum would help with controlling reverberance.

*Too much reverberation might cause **sonic chaos** as everyone will be raising their voice to be heard. On the other hand, a completely dead space sounds unnatural and unsettling.*

The complete elimination of reverberance is incredibly expensive and should never be the



Fig.03/19 The long protrusions in an anechoic chamber are necessary for absorbing lower frequency content.

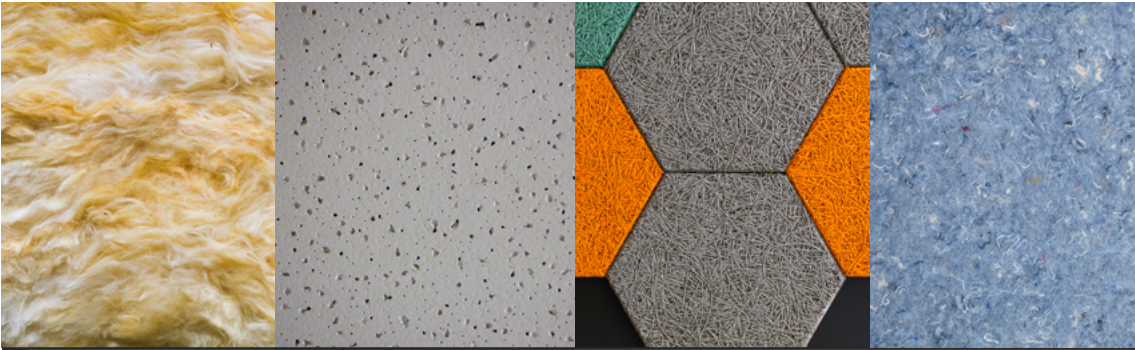

Fig.03/20 Four common sound absorptive materials: (from left to right) mineral wool, acoustic composite tile, wood wool, and recycled jean batting. Their common feature is the highly porous structure.

goal. Such rooms are called **anechoic chambers** and they are used for highly sensitive testing, calibration, recording, and security applications.

Contrary to sound reflection, sound absorption occurs when the incident sound energy is trapped within a material and converted to heat. **The ability of a material to absorb sound is dependent upon the porousness, fuzziness, and flexibility of a material, and for lower frequencies, mass, and depth of the material becomes important.** Fiberglass, mineral wool, spray foam, hemp, or even shredded old jeans are great materials for achieving good sound absorption, as well as thermal insulation in some cases. However, with these materials, there's a tendency for fibers and particles to break off and mix with room air. It is good practice to cover these materials with an acoustically transparent fabric or provide perforations on the facing material. **Acoustically transparent** means that the sound can pass through unimpeded and unchanged, if air can be blown through a piece of fabric it will also allow sound through. For instance, the center speaker in movie theaters can be located behind the curtain, which is acoustically transparent.

Depending on their physical make-up, different materials can absorb different frequency ranges efficiently. **Absorption performance is expressed by alpha value or absorption coefficient, a number between 1 for total absorption**

or transmittance and 0 for total reflection of incident sound energy. **Noise Reduction Coefficient (NRC)** is a single number that signifies a material's overall absorption performance, calculated by averaging the absorption performance at specific frequency bands, specifically 250Hz, 500Hz, 1000Hz, and 2000Hz. NRC can give a general idea about what the sound absorption performance will be, but it is not completely accurate. For example, a 6mm pile carpet with foam underlay may have an NRC of 0.3 but the absorption coefficient at 125Hz is 0.05 meaning that most of the sound energy at this frequency band is reflected back. On the other hand, carpet tiles on a raised floor can have an NRC of 0.4 depending on the assembly, moreover, the air gap underneath, the absorption coefficient at the 125Hz band is higher at 0.27.

Textiles are not absorptive when stretched, however, when pleated to half area or more, a thick fabric like velour can **help control high-frequency content** with an NRC at 0.35 to 0.4. A common misconception is thinking that wood is a good sound absorber. A typical NRC at 0.07, wood is rather a great sound reflector, especially for higher frequencies. That is why in some high-end recording rooms, diffusers on walls feature wood. Wood can be perforated to let sound pass through to an absorbent batting behind, and since it can flex, the wood panel itself can act as

a tuned damper for lower frequencies. However, this is not a common application and would require consultation with an acoustical engineer.

*In any case, **if acoustics is a major concern** in a project, an acoustical engineer should be involved.*

Controlling bass content is especially difficult in almost all cases. *High levels of absorption at the lower frequency bands can only be achieved via **thick and massive materials or deep airtspaces***. The bass content that dwells around the 125Hz band is very hard to control and suppress. However, a gypsum board assembly with an air gap can provide significant absorption; even though gypsum board itself is very reflective for higher frequencies and unless treated, can cause overwhelming reverberance.

Bottom line is, NRC is a good value for quick comparisons but for accurate decision making absorption coefficients at various frequency bands should be individually examined. *As it stands currently, NRC is being replaced by the **Sound Absorption Average (SAA)** value. Instead of sampling 4 frequency bands, SAA is*



Fig.03/21 Wood can be perforated to achieve acoustic semi-transparency. Without perforations it can only reflect sound waves.

vid.03/09 Video on sound reflectivity of untreated gypsum board.



the average of the absorption values from 12 frequency bands between 200Hz to 2500Hz. SAA may provide slightly more accuracy, however, it is still a single averaged number.

Sound transmission is the leftover sound after reflection and absorption passing through the length of one medium to the surrounding next one, whether it is a solid material or air. **Sound Transmission Class (STC)** is a single-number rating that specifies how effectively a building component blocks the transmission of airborne sound between two spaces, an averaged attenuation at various octave bands, similar to noise reduction coefficient (NRC). **Sound attenuation** is the progressive reduction of sound intensity as it travels through a medium. A higher STC rating means more acoustic separation of environments. However, it does not guarantee an efficient separation at all frequency bands, as blocking the lower frequency content is espe-



Fig.03/22 A thick velour curtain with deep pleats can provide some acoustic absorption, mostly at the high end of the sonic spectrum.

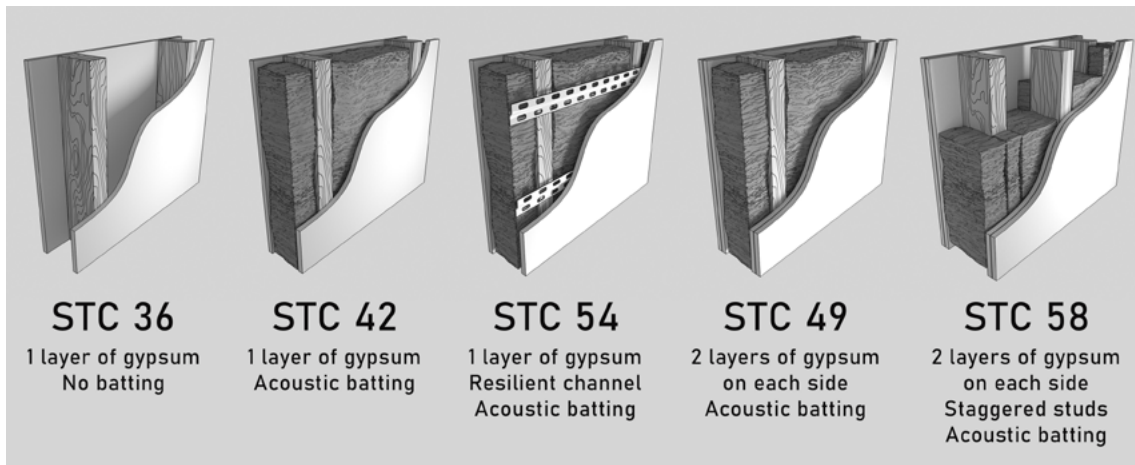

Fig.03/23 Sound transmission class (STC) for various gypsum board assemblies.

cially difficult since it can travel easily and far. **Apparent Sound Transmission Class (ASTC)** is a relatively more recent and accurate representation of sound transmission between adjacent environments, based on occupant perception.

The solid members of a continuous structural system, such as a reinforced concrete floor slab or even a wood joist spanning across two rooms, can carry vibrations between separate acoustic environments, especially the lower frequency content. This phenomenon, sound being transmitted through the building via the structure, is referred to as structure-borne noise. The **Impact Insulation Class (IIC)** describes how well a building element or assembly can resist the transmission of impact-generated sounds. Ceramic tiling or granite flooring has an IIC value of around 30, hardwood flooring is around 35, carpet with an underlay can be as high as 75.

A resilient finish, or underlayment, or raised flooring with resilient joints are good ways to mitigate the **transmittance of impact sounds**. Resilience in this case refers to a material that can dampen energy through elastic deformation, such as rubber or neoprene.

Sound can also leak through the smallest of seams, cracks, and openings, oftentimes negating the isolation attained with a partition or a divider. This phenomenon is referred to as **flanking transmission**, where unwanted sound travels or rather bleeds through a supposed separator between two acoustic environments, often due to bad partition design including, any uncaulked cracks, seams, or gaps, openings between rooms in the plenum (the area between



Fig.03/24 Resilient pads and coils are used to minimize transfer of equipment vibrations to the building.

suspended ceiling and ceiling), unsealed openings and penetrations, unstagged and unsealed outlets, lack of using furring strips or dampening connections with resilient brackets, poor duct, conduit, and plumbing design, poor grill/register placement niches on walls, exposed plumbing, poorly caulked floor-wall and ceiling-wall seams, a lack of absorptive batting in the partition airspace. **Latex acoustical sealant** is a good option for sealing seams as it can maintain its flexibility for a long time, does not harden or crack, and does not lose sound attenuation capability over time.

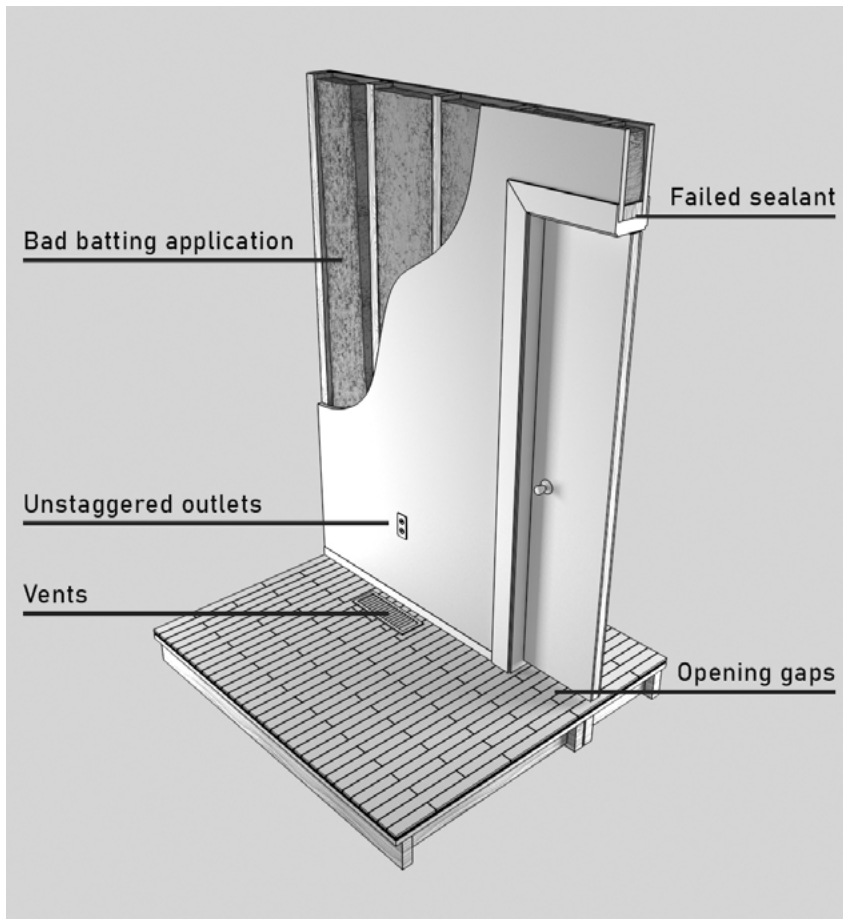

Fig.03/25 Illustration of common flanking points in a residential partition.

An assembly's acoustical transmission performance will only be **as good as its weakest point**. It is always better to address bigger problems like a sound leak through a crack than setting up expensive resilient channels or using high-performance acoustic ceiling tiles.

Unless a partition is fully separating two rooms, in other words, **if air can freely flow** in between, these two rooms are referred to as a common acoustic environment. In classrooms and conference halls speech intelligibility is important to achieve, however, in an open plan bank office, private conversations of customers might require limiting speech intelligibility, therefore achieving speech privacy. Open-plans, movable dividers, or separators between cubicles contribute little to speech privacy. **Articulation index (AI)** is defined as the measurement of speech privacy in spaces with an open plan. AI value below 0.05 indicates confidentiality, and above 0.2 indicates minimal or no speech privacy. Another metric is the *Privacy Index (PI)* which is the inverse of AI in percentage form. A PI value of 100% - 95% indicates confidentiality.

If speech privacy is required, the direct sound should be blocked and absorbed, especially at the **1KHz to 4KHz range**.

Another way to ensure speech privacy is increasing the background noise, ambient sound, or music. **Sound loses intensity with distance**, this means the speech in close proximity will be clearly audible, whereas at distance it would be non-intelligible.

04

SUSTAINABILITY

- *Sustainable thinking and design*
- *Carbon footprint*
- *Embodied energy and recycling.*
- *Life cycle assessment (LCA)*
- *Green building certification*
- *Eco-labels*
- *Green cleaning practices*

Since the 1950s, the connection between global warming and significant loss of ecosystems, declining biodiversity, exacerbating pollution, and the overuse of limited natural resources has increasingly alarmed the global community. *The **environmental movement** started taking shape in the 1960s and became a precursor to today's sustainable design mindset.*

Sometimes referred to as “green design”, **sustainable design** is a philosophy aiming to ensure that today's design needs are met without compromising future generations' ability to meet their own design needs; a definition made by the Brundtland Commission of the United Nations back in 1987. It strives to minimize and potentially reverse negative environmental impact through conscious and efficient design practices. *Understanding and practicing sustainable design is crucial for any interior architect and designer due to the fact that the construction industry, they are a part of, consumes 40% of the extracted raw materi-*



Fig.04/01 View of the Spiral Jetty, a land-art designed by Robert Smithson, contrasting man-made with nature.

als and contributes to 11% of the greenhouse gas emissions, globally. Since the impact is so enormous, any step taken in the right direction is bound to have a significant positive impact. The designer should think and scrutinize the necessity of any form of consumptive decision and refrain from deterioration, depleting, and diminishing. **“Reduce, reuse, and recycle”** is a maxim that encapsulates the sustainable design mindset. The sustainable design mindset urges the designer to consider *extraction, manufacturing, packaging, human rights, labor standards issues, transportation, maintenance, life-cycle, toxicity & off-gassing, water footprint, biodegradability, closed-loop manufacturing, green labels and certifications, end-of-life options* for any material to understand its impact on the environment in short and long term.

Successful sustainable design can only be achieved with a holistic approach, meaning, instead of focusing on discrete decisions based on recyclability, embodied energy, or toxicity, *assessing the overall benefits and impact with careful consideration of life-cycle assessment is often more appropriate.* ASTM E2129 outlines a good framework for thinking about sustainable products: ① environmental impact, ② manufacturing processes, ③ performance of the installed product, ④ indoor air quality, and ⑤ manufacturer’s commitment to sustainability through corporate policy.

Environmental impact would comprise the effects of the extraction of the raw materials, disturbing the local ecosystem, including deforestation or release of chemicals to the environment, as well as the fossil fuels spent in extraction. Toxic emissions are a significant concern for most raw material extraction and purification processes, and often pose a threat to the local environment as well as the people involved in the manufacturing process. Consequently, sustainability issues are intertwined with economic and social issues. But the designer should also consider that local materials are often a better option as they don’t impact the local economy negatively while minimizing CO₂ output due to fossil fuel consumption for transportation. **Local doesn’t immediately mean completely sustainable.** A local silver mine can still leak cyanide if managed improperly, or a local marble quarry will still destroy habitats.

Chemical runoff from some industrial processes can contaminate the soil. Especially the chemicals that are water-soluble can move through the soil reaching underground and surface waterways, aquifers, or move to water bodies and start accumulating on surrounding flora and fauna. **Bioaccumulation** is the gradual and persistent accretion of chemicals and toxins in an organism; and being part of a larger habitat these organisms can be consumed by others,



Fig.04/02 Being at the top of the food chain, bald eagles are often tested to assess bioaccumulation.

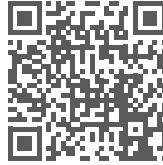

Vid.04/01 Video on bioaccumulation and biomagnification.

which results in **biomagnification**, the gradual accretion of chemicals and toxins throughout a food chain. Bioaccumulative chemicals will ultimately impact the local human population's health and wellbeing.

Rapidly renewable is a term that refers to resources that, after being harvested, replenish within the span of ten years. A very popular example is bamboo, which can be used in many ways, such as plywood core, or veneers, or for extracting textile fibers. Cork, linoleum, and wool are other well-known rapidly renewable material sources. Biodegradable Polylactic acid (PLA) and starch plastic are produced mainly from renewable plant sources, but the associated environmental impact can be extensive, including deforestation, depletion of groundwater, agricultural

runoff, incentivizing highly genetically modified species, fossil fuel consumption for farming, displacing local food production, etc.

*Ultimately **when there's an environmental advantage there are also disadvantages.** How the designer balances the total harm and benefit a material throughout its useful life, considers its overall positive impact for society, and how it can be safely disposed of are exceedingly important.*

For instance, titanium utilized in aircraft manufacturing is very energy-intensive to manufacture and process, however, by making aircraft lighter, thanks to its high strength-to-weight ratio, it contributes to reducing the release of CO₂. Furthermore, it is highly recyclable and due to its high-value, recycling is actually feasible and widely practiced.

Tab.04/01 Questions for assessing environmental impact of various materials and finishes.

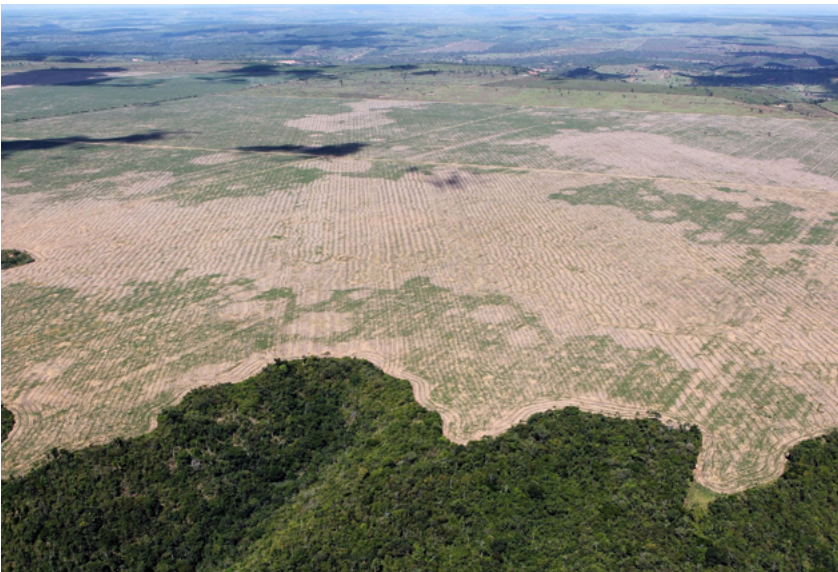

Fig.04/03 Excessive agricultural demand results in deforestation to create farmland.

(1) Are the extraction and manufacturing processes non-destructive and non-toxic? Is the main resource renewable? What is the ratio of recycled to virgin content?
(2) Are the extraction and manufacturing processes humane, fair, and beneficial to the local community?
(3) Are the resources extracted, or materials manufactured locally, within a 500 mile radius? Are the packaging requirements modest?
(4) Is the manufacturer committed to environmental and social sustainability? Does the manufacturer offset resulting carbon emissions?
(5) Is the material fully or highly recyclable? Is the recycling process feasible? Is the recycled content of high or lesser quality? Can the material be reclaimed or repurposed?
(6) Does the material or finish feature established and widely recognized green labels or certifications? Does the material or finish supply credits towards green building certifications?
(7) What is the life expectancy of the product? Does the material emit any VOCs? Are cleaning and maintenance practices feature non-toxic and biodegradable products?
(8) What are the end-of-life procedures of the product? How much of the material is expected to contribute to landfills? Is the material readily biodegradable or compostable?



Fig.04/04 Cork is a rapidly renewable material, majority of which have to be transported from Europe.

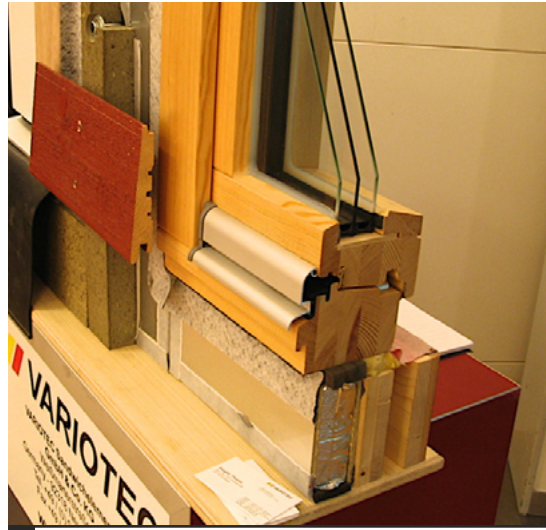

Fig.04/05 Meeting the passive house standard requires a multi-layered and complex insulation solution.

CARBON FOOTPRINT

Carbon footprint is the total amount of greenhouse gases generated by any process, either directly or indirectly. These greenhouse gases include carbon dioxide (CO₂), but also methane (NH₄), nitrous oxide (N₂O), and fluorinated gases. Carbon footprint is not limited to the emissions during a product is being used, but also the emissions during manufacturing, transportation, construction, and disposal.

*The carbon-neutral design mindset suggests **smaller is better**, in other words less manufacturing and less building results in less carbon emission.*

Carbon-Neutral Design (CND) refers to a net zero carbon footprint associated with all processes from the extraction of raw materials to occupant behavior. Since building construction and operation requires a significant amount of energy, sometimes the carbon released needs to be balanced by reducing or sequestering CO₂ somewhere else, through some other process.

This is called **carbon offsetting**, it is essentially compensating for carbon emissions outside of the manufacturing or use processes, such as funding renewable energy, sustainable agriculture, reforestation, or simply purchasing carbon credits.

Net-zero building refers to a building that is so energy efficient that it generates as much energy as it uses, through highly efficient insulation, solar energy panels, geothermal heating and cooling, integrated wind turbines, or various other means. Some Passive House Standard compliant buildings are examples of net-zero residential design. The interior is sealed so well from the exterior that in theory no heating/cooling is necessary, thus the label 'passive'.

Biomimicry involves using forms, processes,

vid.04/02 Video on carbon offsetting and how it works.



vid.04/03 Video on the experience of living in a passive house.



functions, and systems found in nature as a source of inspiration for the design and development of products that are more efficient, durable, and sustainable. A direct translation of the term would be “emulating life”. Studying the chemistry of light generation in a firefly to invent a source of illumination, or studying the peregrine falcon to optimize the aerodynamics of an aircraft, or using ant colonies as a jumping-off point to develop dwelling complexes can be considered biomimicry examples. If achieving sustainability is the ultimate goal, where waste, resource depletion, and overall negative environmental impact are aimed to be eliminated, it is only logical to look at and understand a source that has established a balance within itself and with its surroundings.



Fig.04/06 The burrs of the burdock plant were the natural inspiration behind Velcro.

RECYCLING

The **embodied energy** of a material or product is the total energy consumed during the entire production process. This includes extraction of raw materials, refinement, processing, manufacturing, packaging, as well as transportation, shipping, and delivery procedures. For instance, wood is among the materials with the lowest embodied energy, especially when compared to other construction materials like steel, concrete, or various plastics. Wood is simply felled, cut, dried, and processed without significant requirement for refinement, heat, pressure, transportation, etc. On the other hand, Aluminum’s embodied energy is very high due to the very energy-intensive refinement process, but after being created, the material can be recycled indefinitely and with high efficiency. Meanwhile, in addition to its high embodied energy, PVC is notoriously hard to separate from waste streams and recycle. The embodied energy of aluminum is justified in the long run through a lifetime of energy savings, whereas the same cannot be said about PVC.

Recycling refers to collecting, separating, reprocessing, and reusing waste materials. The recycled material content can be of high quality and highly feasible, equal to the virgin material such as in titanium. Or, it can be slightly lesser quality, so that it can be mixed with virgin material at various percentages to keep the resulting material quality at a certain level. For instance, up to around 30% of re-melted glass, also known as cullet, can be mixed with virgin glass to make clear float glass. Or the quality of the recycled material can be low and it can only be used for lesser products. Recycled PVC can have so many impurities due to the numerous additives used, mixing it with virgin PVC drastically reduces material quality and predictability. Low-quality recycled output coupled with low virgin material costs result in limited recycling. For PVC, recycled



Fig.04/07 Even the separated PET waste features multiple contaminations.

content is around 3% of all that is manufactured, the rest goes into a landfill. **Cross-contamination** is another issue for recycling; the material itself can be highly recyclable, however, it might be combined with other products that would require further processing, increasing recycling costs, sometimes exceed virgin material production costs. For instance, PET bottles are highly recyclable but they are often contaminated with a wrap-around label that is manufactured from a different plastic and an adhesive from yet another plastic, in addition to the residue from the liquid carried inside. The separation and cleaning processes increase costs to a level that only around 30% of PET bottles are recycled.

*Even though providing the manufacturer an aura of credibility, the labels “recycled” and “recyclable” can be **inaccurate and misleading** without knowing the exact percentages, which can potentially result in carefree consumer behavior.*

There are 4 important terms regarding recycling. **Pre-consumer** recycled content, or post-indus-

vid.04/04 Video on the intricacies of aluminum recycling.



trial recycled content, refers to the material that is recovered from the waste stream of another manufacturing process. Fly-ash, which is burnt coal ash, is one such example. On the other hand, **post-consumer** recycled content refers to used and disposed materials that are reclaimed and reprocessed. For example, recycling newspapers or water bottles. **Downcycling** produces materials that are of lower performance and degraded quality. Most plastics are recycled this way. After several cycles material becomes waste. Oppositely, **upcycling** produces materials of higher quality and usefulness. Homasote® panels and Richlite® are two examples of this process, which are recycled common paper products manufactured to be robust building products.

Biodegradability and compostability have been important terms associated with environmentally friendly material manufacturing. **Biodegradable** essentially means disintegration by living things; that a material can be broken down into CO₂, water, and base building blocks through natural processes, including exposure to sunlight, elements, bacteria, fungi, algae, etc. This label can be misleading, as the length of the process is not clearly defined; so, a material that degrades over decades can still be labeled biodegradable. If material is biodegrading slowly, over a decade, it will disintegrate into smaller particles, such as microplastics, and have ample opportunity to contaminate water resources or move up the food chain. Furthermore, when a biodegradable plastic is buried under mountains of trash with no access to oxygen and sunlight, it may not degrade at all. Also, specific species of bacteria may be needed to be present to carry out the decomposition. **Compostable**

vid.04/05 Video on Richlite®, an upcycled panel product.





Fig.04/08 Compost mounds need to be frequently aerated, otherwise buried waste won't break down.

means that the material undergoes a biological degradation process leaving no toxic residue. Compostability is clearly defined and regulated better than biodegradability. In order to label a material compostable, 90% of the material must be converted to CO₂, water, and biomass **within 90 days**. There are various types of composting such as vermicomposting involving worms, or windrow composting involving periodic aeration. A “compostable” label does not guarantee that the product will break down through domestic composting processes.

Reclaimed and repurposed materials have significant importance in sustainable thinking. Many materials can be **repurposed and reused**, discarded brick, lumber, tires, etc.; cheaper and faster than recycling. Reclaimed materials and products can be creatively refinished, repurposed, and utilized in a different context and for different use. The “Rover Chair” by Ron Arad is a famous example where a used car seat was taken out of context and with minimal additions transformed into living room furniture. The options are limitless as long as there’s an



Fig.04/09 Reclaimed wood imbues any design with a unique visual character.

open eye to see the potential. **Design for disassembly** is another important concept related to sustainability, which leverages flexibility, partibility, and convertibility, suggesting that new components can be added and subtracted to meet changing needs of the user. This concept also applies to inter-changing the parts that are worn or damaged. It is better to change a carpet tile worn under the use of chair casters rather than changing the carpet of the whole office, or changing a warped wood shelving instead of throwing away the whole cabinetry. The design for disassembly mindset favors mechanical fasteners against adhesive use, or simplicity over complexity and embellishment.

Life Cycle Assessment (LCA) is a systematic analysis method used to evaluate the environmental impacts associated with all stages of a

vid.04/06 Video on life cycle assessment (LCA).





Fig.04/10 The KSU College of Architecture, Planning and Design is housed in the LEED Silver certified Seaton Hall.

product's life. It encompasses environmental and technical data from raw material extraction through manufacturing, use, and disposal or recycling. Life cycle assessment is probably the most important way to look at sustainability over the long term. A product might have minimal embodied energy, cheap to produce, but if it deteriorates quickly and cannot be recycled as it is hard to identify and separate, it goes to contribute to a landfill. Therefore, contrary to the information on paper, it may not be sustainable at all. PVC is one such material. Due to the extensive diversity of additives it is very hard to separate from waste streams and recycle. **Life Cycle Thinking** is considering the full range of environmental, social, and economic impacts of a product or service from cradle to grave.

GREEN BUILDING CERTIFICATION

The term **green building certification** refers to processes that evaluate, recognize sustainable design and construction efforts based

on criteria related to energy efficiency, water usage, materials, indoor environmental quality, and site development. There are multiple organizations throughout the world granting green building certification. ASTM International, has developed hundreds of standards to ensure the design and construction of sustainable buildings, which form a foundation for codes such as the International Green Construction Code (IgCC) and building sustainability rating systems such as Leadership in Energy and Environmental Design (LEED).

LEED is the most prevalent green building certification program across the globe. This program created a systematic framework to evaluate building's as well as neighborhood's sustainability performance, ultimately helping clients, investors, designers, contractors to make environmentally conscious decisions.

Each decision, starting from building site to maintenance and operation is awarded points

according to the *LEED framework*, and projects are awarded one of the following ratings: *LEED certified, silver, gold, and platinum*. LEED certification displays a commitment to sustainability, environmental stewardship, and responsible building practices. It demonstrates a dedication to reducing carbon emissions, enhancing energy efficiency, conserving water, improving indoor air quality, and utilizing sustainable materials. LEED certification also signifies a commitment to the well-being of building occupants and the broader community, promoting healthier, more sustainable living and working environments.

LEED has multiple branches of evaluations, the ***LEED Interior Design + Construction (ID+C)*** program focuses on certifying various types of interior spaces and contains the following seven categories, each of which are separately evaluated: (1) location and transportation, (2) sustainable sites, (3) water efficiency, (4) energy and atmosphere, (5) materials and resources, (6) indoor air quality, (7) innovation.

Even though LEED has immense popularity in the US and prominence across the globe, there are other formidable environmental sustainability certifications. the ***Building Research Establishment Environmental Assessment Method (BREEAM)*** is another popular certification program, that is more popular in the United Kingdom, that has a different set of criteria and evaluation process that is claimed to be more rigorous and quantitative.

Living Building Challenge is another comprehensive sustainability standard. *Instead of only focusing on minimizing the negative environmental impact, this certification aims to improve*

the wellbeing of occupants, community, and the local environment of a building, aiming to be regenerative. One important aspect of the Living Building Challenge is, it promotes a Red List that include but not limited to vinyl derivatives, BPA, phthalates, paraffins, formaldehyde, halogenated flame retardants, toxic heavy metals such as arsenic, mercury, cadmium, and lead, asbestos, etc. It also introduces the Declare label for materials and expects products in the Declare Database to be used to the outlined extent. *Living Building Challenge is putting a strong emphasis on salvaged and reclaimed materials, and diversion and integration of waste*.

Another program relevant for interior spaces is the ***Well Building Standard***, which is developed to create health and wellbeing-focused environments with some unique standard categories such as *nourishment, movement, sound, and mind among others: air, water, light, thermal comfort, materials, and community*. In terms of material specifications, the Well Building Standard is primarily concerned with the materials and the chemical byproducts that can threaten the wellbeing of individuals during the construction, remodeling, furnishing, and operation of a building. There's a requirement for transparency in materials, achieved through labels of independent organizations such as: the declare label, mentioned above, Health Product Declaration, Cradle-to-Cradle, or Greenguard. *The materials listed in the Living Building Challenge Red List, mentioned above, and the Cradle-to-Cradle Restricted Substance List are expected to be completely omitted*.

ECO-LABELS

In the context of materials and finishes, ***eco-labels*** are identifiers that describe a product's ability to meet various health, safety, and sustainability standards. The Environmental Protection Agency (EPA) defines eco-labels as identifying marks, owned or managed either by

Vid.04/07 Video on the Living Building Challenge.



government agencies, non-profit organizations, or private sector entities, associated with products that indicate an ability to meet or exceed a single or a group of environmental performance criteria. *Eco-labels are awarded based on an **independent evaluation** of products, or **self-reporting** by manufacturers.*

With the growing interest in environmental protection and sustainability, *a consciously vague or misleading language and marketing strategy on product information, advertisement, promos, and sales pitches created the issue known as **greenwashing**.* The various manufacturer claims might not be all-out misinformation, but could be hiding negative impact and trade-offs. Biodegradable, single-use plastics or starch plastics are one example of greenwashing. There are certain conditions to be met for the breakdown to happen, such as the presence of certain species of bacteria or continuous air and sun exposure. Most landfills cannot meet these criteria and the readily disposed of plastic stays pretty much intact.

*The bigger problem is that the biodegradability claim influences the end-user to quickly **dispose of products without much thinking**, causing more unseparated trash, whereas minimizing waste by more durable multiple-use products would have been more environmentally friendly.*

When trying to assess if a product meets health, safety, and sustainability standards, instead of relying on manufacturers' claims, it is better to focus on eco-labels that are either backed by established non-profit organizations such as the Environmental Protection Agency (EPA), or the Underwriters Laboratories (UL), or labels that are widely accepted throughout the industry such as Green Seal or Declare. Some of the most relevant eco-labels are explored below.

GREEN SEAL ● This is a non-profit certification program, established in 1989, developing standards for products and services to promote sustainability, reduce waste, and improve health and environmental performance. The certification covers a broad gamut of products and services, aside from construction materials, cleaning products, food packaging and preparation services, hospitality services, paper, and paper products. Green Seal is integrated into the LEED evaluation process and LEED points can be accumulated with certified products.

GREENGUARD ● Published by UL, products carrying this particular label meet low emission standards contributing to minimizing indoor air pollution. Products carrying the Greenguard Gold Certification meet even stringent VOC emission standards and are claimed to be safer for children

PRODUCT LENS CERTIFICATION ● Also published by UL, aims to provide clear and meaningful communication of risks and hazards associated with various products, ensuring overall transparency based on actual usage of the product. Like Green Seal, certified products can also generate LEED points.

ENERGY STAR ● Established by the EPA and the US Department of Energy, is a mark of energy efficiency, providing a concise and comparative picture of the energy usage of products. The evaluation processes are carried out by independent agencies. With its yellow and black graphics, it is easily and immediately identifiable. This certification is provided for appliances, HVAC equipment, computers, and even entire buildings and manufacturing plants.

DECLARE ● Published by Living Future Accreditation and recognized by the Living Building Challenge and LEED, this label documents a product's story, contents, composition, life expectancy, and end-of-life options. The online database lists all Declare products, some with Red List Free mark. **Red List** includes ingredients that are known to

Link 04/01 Link to the Transparency Database Precautionary List.



be harmful to human health and the ecosystem.

HEALTH PRODUCT DECLARATION (HPD) ● Developed by GreenCE, is a standardized product content report that outlines ingredients that can be considered environmental health hazards. HPD is self-reported, unlike the other eco-labels. HPDs are also a way to accumulate LEED points. Currently, third-party verification is not required.

CRADLE TO CRADLE (C2C) ● This certification evaluates brands based on their commitment to five sustainability categories: material health, material reuse, renewable energy and carbon management, water stewardship, and social fairness. Five achievement levels are assigned to independently evaluated products signifying the manufacturer's dedication to sustainability.

TRANSPARENCY ● This is a database established by Perkins + Will, that informs designers and the public about the health impact of end-user materials as well as manufacturing chemicals and ingredients. The **Precautionary List** is similar to the Red List but detailed information is provided for each item. The website also features a stream of news on the health impact of building materials and the industry.

GREEN CLEANING PRACTICES

In order to maintain the spatial conditions, as well as occupant health and standard of living, regular cleaning practices are a necessity. Using the correct cleaning product on every surface is important in terms of minimizing user exposure and increasing the useful life of surfaces. However, many cleaning agents and products used to maintain the materials and components

in living and working environments contain toxic chemicals such as harsh acids, and solvents contributing to the VOC content of the environment, **degrading air quality**. At the very basic level, the cleaning products can act as an irritant and cause immediate harmful effects on the eye, skin, or the respiratory system and provoke allergies, not just for the occupants but also for cleaning crews as well.

The biodegradability of cleaning products is another crucial consideration, especially their ability to degrade and disintegrate after being flushed down the drain. However, there are different types of water and different drains within a building. **Potable water** refers to drinkable water, **grey water** refers to wastewater without any contamination, and **black water** refers to contaminated water. The contamination in question includes excrement and chemicals. The used water from sinks, showers, and baths are considered greywater and may only be subject to light treatment, unlike black water from toilets that has to be treated at sewage treatment plants.



Fig.04/11 The strict cleaning procedures introduced after COVID-19 exposed the occupants to higher levels of VOCs.

*This means that the **non-biodegradable cleaning products** mixed with greywater streams can affect garden soil, water systems, plant, and aquatic life and they can persist for longer periods, possibly moving up the food chain.*

*It is possible to develop a **green cleaning strategy** to ensure that environmental impact is minimized. Product packaging and shipment efficiency, safety, and recyclability, as well as cleaning procedures that minimize exposure and allow for efficient application are important. EPA manages the **Safer Choice Program** which identifies certified cleaning products that are safe for human health and the environment. LEED points can be accumulated when green cleaning policies are in place, the products and equipment have a low environmental impact, and are **properly stored in designated locations**, such as housekeeping closets. Furthermore, the designer should be conscious of the cleaning requirements for the materials being specified, as to minimize the need for frequent cleaning with harsh cleaning products.*

05

PAINT & WALLCOVERING

- *Typical paint components*
- *Paint history and types*
- *Gypsum and plaster*
- *Paint application and disposal*
- *Wallcovering history and types*
- *Wallcovering application*

Paint is a liquid surface coating that forms a protective film upon evaporation. It often contains pigments and various additives for visual effect. Cave paintings are the earliest applications of paint, some dating 40 to 50 thousand years ago. The application of paint with the specific intention to visually enhance a space came from the ancient Egyptians, known to be brilliant paint manufacturers and artists. Some of their wall applications still possess their brilliancy today. Ready-mixed, or prepared paint, became widely available towards the end of the 19th century, enabled by the industrial revolution, transforming the look of interiors as well as products. Today, paint is the most inexpensive method to protect and visually enhance a surface.

Paint is a mixture of 4 fundamental components: ① *pigments to give color to the coating,* ② *additives to enhance the performance,* ③ *binders to hold the particles together,* ④ *solvent to enable transfer and spread to a surface.* The



Fig.05/01 Dating back to 13000 years ago, the Cave of Hands is located in Santa Cruz, Argentina.

amount, balance, and quality of each one of these will affect the quality of the paint job. Lower-grade content would be cheap but the result won't be satisfactory. Higher-grade content may be easier to work with and suitable for DIY situations but might not be justified in all scenarios due to budget limitations. Trained professionals can achieve good results with relatively lesser quality paint, that is why contractor-grade paint is cheaper than retail-grade paint.

Pigments are powdered chemical compounds, such as copper phthalocyanine or titanium dioxide, that impart color to and enhance brightness of the mixture. There are two types of pigments; prime pigments that introduce the color, and extender pigments that enhance coloring properties. Higher pigment concentration, or pigment load, provides a coating with better saturation, coverage, and hiding power, however, it is relatively expensive. On the other hand, lower pigment concentration looks more desaturated, less brilliant and intense; appear-

ing somewhat dull and transparent. Depending on the resin content, paint can appear relatively glossier. Too much pigment in a paint mixture can be detrimental to the application, causing gaps to form between particles. The application surface becomes textured, matte, permeable, and less resistant to abrasion. It is the overall balance and appropriateness for the purpose that determines the performance of the paint.

Extender pigments are colorless and inert chemicals such as calcium carbonate, calcium sulfate, silica, clay, talc, etc. These are added to adjust or improve the paint's properties such as glossiness, consistency of the application, and enhance durability and abrasion resistance. Extender pigments are typically low cost compared to prime pigments; they give the paint body and bulk. Typically, higher quality paint has a higher prime-to-extender pigment ratio. Even though it functions similar to extender pigments, **titanium dioxide**, TiO_2 , is an important prime pigment that has a bright white color and it is



Fig.05/02 Titanium Dioxide (TiO₂) is a pure white pigment with highly useful properties.

widely used to introduce brightness, opacity, and hiding power to paint. It is relatively expensive.

Recently TiO₂ has been classified as a suspected carcinogen by the International Agency for Research on Cancer (IARC). It is much less toxic than lead, but it might ultimately share a similar fate.

Additives are special-purpose ingredients that improve or fine-tune the performance of the coating. There's a large selection of additives available such as thickeners that improve the consistency of the paint; dispersing additives that are used to eliminate flocculation, which is forming of small loose aggregations within the mixture; wetting agents that improve the liquid absorption capabilities of the powdered paint components; antisetling agents that increase the viscosity of the mixture delaying the drying and settling processes both during application and storage; defoamers that eliminate foaming which causes coating defects during application; coalescents that facilitate continuous film formation during application; UV stabilizers that prevent UV degradation; biocides that inhibit mold and mildew growth; fire-retardants that



Fig.05/03 In order to mitigate the tiny craters, defoaming agents should be mixed in the paint formula.

establish fire resistance, achieving up to ASTM E-84 Class A rating depending on the amount of additive mixed in. It is also possible to add various additives to introduce texture, such as sand texture, smooth texture, or coarse texture additives.

*Designers should be careful as paint additives, even though they are highly useful, can significantly **impact toxicity levels and VOC emissions.***

Binders hold the contents of the paint together and enable the film coating to adhere to the application surface. Gum Arabic is a natural secretion by acacia trees, primarily used as a binder since 3000 BCE in the Middle East and Africa. Binder directly determines paint's performance in terms of abrasion resistance, scrubability, color and gloss retention, etc. Typically, binders have very **high density and limited flow**, they need to be mixed with a solvent to make paint application possible. Common binders include acrylic, alkyd, epoxy, latex, and polyurethane; binder type needs to match solvent type.



Fig.05/04 Acacia tree sap, or gum arabic, has been used as a natural paint binder for thousands of years.

The ratio of the binder determines the sheen level of a paint application. **Lower sheen** levels feature lower binder ratios, they are harder to maintain, however, they also conceal imperfections, are easy to touch up, and produce no glare. On the other end of the spectrum, **high gloss** finishes feature higher binder ratios. They are easier to clean and maintain, however, they highlight imperfections and require extensive substrate preparation. The lowest sheen levels are best for ceilings where substrate prep is more expensive and almost no traffic will be received, and the highest sheen levels are appropriate for conditions where ensuring hygiene or maximiz-



Fig.05/05 An eggshell paint finish produces a smooth gradient when interacting with light.

ing daylighting is an important factor. Typically, manufacturers assign a name for each sheen level based on the percentage of reflectivity; some common ones are flat (up to 10% reflectance), eggshell (10% to 20%), satin (20% to 35%), semi-gloss (35% to 65%), and high-gloss (65% and up).

Solvents, or thinners, facilitate the transfer of paint components to the application surface, sometimes referred to as “vehicle”. They increase flow, enable a uniform spread, and allow the penetration of the application surface. Solvents are not part of the cured application; they evaporate leaving a consistent film coating

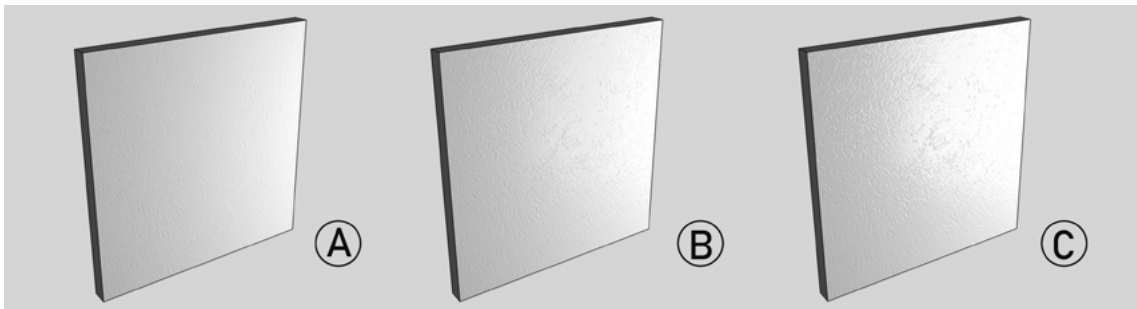

Fig.05/06 Different levels of sheen in paint applications: eggshell (A), satin (B), and gloss (C).

of the other three of the components of the paint. *The amount of solvent negatively affects **coverage and hiding power** of paint, cheaper paints feature proportionally more solvent.* Spraying applications might necessitate higher solvent content to increase flow and minimize clogging. One gallon of paint typically covers 300 to 400 square feet of wall surface. However, the number of coatings ultimately impacts how much paint is needed. For repainting over the same color, one or two coats would be sufficient, for darker, deeper, or lively and saturated colors multiple coats would be needed. Absorbency of the substrate might affect the number of coats, if not primed properly gypsum board or plaster can soak a significant amount of paint. *The **complete curing** of paint can take up to 2 months and some manufacturers suggest refraining from wiping or washing the application for around two weeks.*

There are two major paint categories based on the solvent utilized: water-based and oil-based. **Water-based paints** use water as the solvent, which are further categorized based on binders as latex paint, acrylic paint, or acrylic latex. Some advantages include fast curing times and significantly low VOC emissions, convenient cleanability with soap and water. Latex paints feature better elasticity, they are resistant to cracking and retain color well. They are breathable, allow moisture through, rather than causing it to build up in the substrate, which may end up resulting in mold and mildew growth.

*The latex paints currently available in the market **can match oil-based paint performance** and some even exceed it. There are extremely durable water-based paints in the market, up to 25000 scrubs in accordance with ASTM D2486.*

Also referred to as alkyd-based, **oil-based paints** feature alcohol, mineral spirits, or paint thinners as the solvent. Oil-based paints are



Fig.05/07 Oil-based paint is appropriate where moisture exposure or scuffing is expected.

known to be durable, ideal for trim, woodwork, and cabinetry applications, especially moving or sliding parts; they can resist wear and impact exceptionally well. They provide higher washability and scrubbability, do not allow moisture penetration, hence commonly found in wet spaces. They also have higher coverage, a smoother look, more forgiving to substrate imperfections; longer drying times helps to conceal brushwork. Despite their advantages, oil-based paints have some significant disadvantages. They are relatively costly; require hazardous chemical solvents for cleanup; release a significant amount of VOCs when drying, to an extent that their use is restricted in some states, such as New York, Pennsylvania and Virginia. Water-based paint cannot be painted over with oil-based paint.

*The VOC emission levels for architectural paint are **regulated by EPA under the Clean Air Act (CAA)**, however, designers should consider that this act mainly targets ambient air quality and does not guarantee low toxicity in indoor environments. Some states apply further restrictions to VOC emission levels.*

In addition to water-based and oil-based paint, there are many other types of paint that feature

different formulations. **Clear coatings**, such as clear epoxy and polyurethane, does not contain pigments and primarily applied to provide protection or enhance appearance. **Stains** have a high concentration of solvent and low concentration of pigment and binder, intended to penetrate the application surface and provide a transparent tint. Paint can also have very specific functionality. **Intumescent paint** is a fire-resistive film coating that foams and expands when exposed to heat above around 200°F creating an insulating barrier, mainly used on steel or wood structural elements. The number of coatings gives 30- to 120-minute fire protection; though an excessive number of coats might result in sagging. It is possible to apply a compatible topcoat in any color.

GYPSUM & PLASTER

Gypsum and plaster are the two most common substrates for paint as well as wallcovering applications, therefore a fundamental understanding of general properties and construction is imperative.

Gypsum board, also known as drywall or gyp-board, is a very common wall and ceiling substrate. Gypsum is the name given to a naturally occurring and highly common mineral, calcium sulfate dihydrate ($\text{CaSO}_4 \cdot 2\text{H}_2\text{O}$). It is a non-hazardous, non-toxic chemical, though in powder form, that is commonly encountered

on construction sites, can **irritate eyes, skin, and respiratory system**. The mineral is first heated into an intermediary product known as calcined plaster, which is later mixed with water and sandwiched between paper facers. Evolved from a product called plasterboard, the first gypsum boards manufactured in 1916 featured paper-felt facers, in the next two decades the construction of the board improved and transformed into the version with paper facers widely in use today. It has been a consistently popular construction material since the 1940s.

Aside from the high energy cost of the baking process, **gypsum requires quarrying** which results in deforestation and habitat loss. However, gypsum is also fully and infinitely recyclable. The paper facers on both sides are removed along with screws and nails, which are also fully recyclable. The downside is, the amount of contamination reduces the quality of recycled material. Therefore older boards from demolition waste require extra processing, and only so much recycled gypsum is allowed in newly manufactured boards. But, ground gypsum has many uses other than being recycled into gypsum



vid.05/01 Video on gypsum board manufacturing and use.

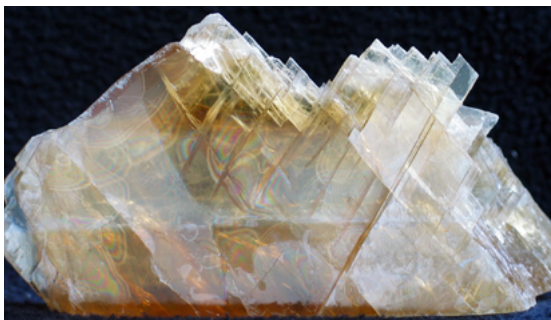

Fig.05/08 Gypsum crystal before processing.



Fig.05/09 An abandoned gypsum mine.

boards, it can be used to amend the soil, as an additive for other construction materials such as plaster, for water treatment, etc. However, if gypsum ends up in landfills, untreated, there's a possibility of producing toxic gases due to bacterial activity.

There is a wide selection of gypsum board types, aside from the regular product. Gypsum is inherently fire-resistant, but it starts to crumble after 30-minutes of exposure. *Fire resistive gypsum boards are called **type-X boards***, these feature glass fibers as well as other core additives to achieve 1-hour fire resistance per each 5/8" thick board and 45 minutes for 1/2" thick board. Multiple boards can be layered to meet exact building code requirements. There is a type-C version available with improved performance.

*If some form of impact, piercing, or sustained application of force is expected, **abuse-resistant or impact-resistant gypsum panels** may be a good option.* These panels uniquely feature a fiberglass mesh between the core and the backing. A **glass-reinforced gypsum board** is a lightweight and high-strength alternative to the regular gypsum board. It is somewhat water and mold-resistant.

Moisture-resistant gypsum board, or *green board*, features a green-colored moisture-resistant backing. It provides resistance against humidity, however, it is not completely water-resistant. There's a higher performance **foil-backed** version, where the moisture-resistant backing is substituted with a vapor retarder aluminum foil. For both types, the rest of the gypsum board is standard. Gypsum, when allowed to get wet, it can sag and facilitate mold and mildew growth. There's a **sag-resistant gypsum board** available; these are used as ceiling boards. The core is strengthened with additives or reinforced with glass fibers; they are lighter weight than regular drywall boards.

The standard 1/2" drywall can be bent at a radius of 10ft and 1/4" drywall can be bent at



Fig.05/10 Green-board is appropriate where some moisture exposure is expected.

a 5ft radius. A **flexible gypsum board** is a 1/4" thick board that can be curved around a 1ft radius without warps, bows, crumbling, or cracking. No wetting facers or scoring/kerfing for very tight curves is needed.

Prefinished gypsum boards save installing costs and time, eliminating dust and debris. There are benefits such as high washability, low maintenance, and fire resistance. They can feature vinyl or textile surfaces with various colors or textures.

In the **standard GA-214**, the Gypsum Association defines 6 **levels of gypsum board finish**, that are commonly referenced in modern construction projects. Each level of finish outlines criteria to achieve incrementally higher finish quality and smoothness, based on how much visual exposure and scrutiny the surface will be subject to. The lowest level, Level 0 is appropriate for temporary construction, is a completely unfinished application featuring no taping, sanding, patching of any kind. Level 1 is

via.05/02 Video on curved drywall application.



appropriate for areas where the surface will be concealed and away from public view, features seams treated with taping and joint compound, tool marks, and ridges are tolerable. On top of Level 1 recommendations, Level 2 features covered and coated fasteners as well as a thin coating of joint compound on all seams; it is appropriate for use as a tile substrate, or in areas with low aesthetic priority such as storage rooms or garages. Level 3 features an additional coat of joint compound on fastener heads and accessories, all joint compound is expected to be smooth and free of any tool marks or ridges; appropriate as a substrate for textured wallcovering or paint applications. Level 4 is appropriate for smooth paint and thick profile backed wallcovering applications, and level 5 recommended for high sheen smooth paints, especially if side lighting or grazing lighting is expected, and thin profile wallcovering applications. Both levels feature a smooth surface, level 5 featuring an extra thin skim coat of joint compound. The **standard ASTM C840** can also be referenced for this process. It defines a stricter specification for the application and finishing of gypsum boards.

Plaster is a thick viscous material, a mixture of gypsum, water, and sand that hardens as it dries and becomes rigid and brittle. The mixture can be referred to as mud. **Gypsum plaster**, also known as plaster of Paris, uses gypsum as a binder; it is comparatively more common. This type of plaster is targeted towards interior applications. Too much moisture exposure



Fig.05/11 Plaster application over cross wood lath can still be found in some older housing.

can cause mold and mildew. It is commonly reinforced with glass fiber for enhanced performance. Joint compound is a specific mixture of gypsum plaster. Gypsum can be substituted with cement or lime to achieve different types of plaster. **Cement plaster**, also referred to as stucco, uses Portland cement as a binder. It is relatively more durable, can be used on exterior walls. It is possible to mix in glass fiber and vermiculite for added strength. **Lime plaster** is permeable and inhibits mold and mildew growth. It is less brittle than gypsum and cement plaster and less prone to cracking.

Around the 1940s, before gypsum wallboard became a widely used material, wood lath and plaster was the dominant wall construction method. The application was expensive and



Fig.05/12 Three distinct levels of gypsum board application according to GA-214.

time-consuming. There are lath and plaster walls and ceilings still present in houses built before the 1940s. They can be harder to repair than drywalls, and might require relatively costly replacement.

Compared to gypsum board, plaster is a slightly more durable application and it provides a relatively tighter seal and good acoustic separation. Vermiculite can be introduced to the mixture for improved fire resistance. **Plaster is brittle after it is completely dried, building movement may introduce cracks to the material, therefore it needs routine maintenance.** Drying times are shorter than drywall skim coating and application is relatively quick, however, it requires skill to install, therefore it is costly.

Contemporary applications feature one of the many types of metal or fiberglass lath. Lathes are typically slightly furred, meaning spaced from the attached substrate, providing support for the plaster. Diamond wire lath is a simple wire mesh. Paperback wire lath is attached to a backing paper for easier installation. **Expanded metal lath** features some inherent depth to hold onto multiple layers of plaster application. **Ribbed lath** features even deeper ribs for more robust plastering, much more dimensionally stable than other options, and suitable for ceiling applications.



Fig.05/13 Laborious to install, a furred diamond wire lath provides good basis for plaster to hold on.

ing applications. Exterior applications require an exterior grade galvanized metal lath, as plaster tends to soak up moisture and can cause corrosion.

Typically, plaster is applied in three coats – **1 scratch coat** is applied first to create a combed surface for the second coat, commonly referred to as **2 brown coat** to attach. This layer is left rough and open for the application of the smooth **3 finish coat**, third and last. Each coat is applied after the previous coat has dried. A two-coat or thick single coat application is possible but they provide less durability and protection.

Plaster, has **excellent moldability and retains intricate detail.** Glass fiber reinforced plaster is highly appropriate and widely used for molded decorative applications, such as crown moldings, cove moldings, chair rails, or wainscoting.

PAINT APPLICATION

For any common paint application, surface preparation is the most important procedure to ensure a **well-performing and aesthetically pleasing finish.** Since paint is essentially a very thin film, often 3 to 5 mils, any irregularity or imperfection on the substrate is directly telegraphed to the surface. A **mil** is a thousandth of



Fig.05/14 With silicone molds, plaster trims can feature highly intricate detail at a reasonable cost.

an inch, equals to 25.4 microns. New substrates are more predictable, on the other hand, older substrates are full of surprises. They can feature corrosion, decay, soaked chemicals, moisture build-up, or even feature hidden fungal growth; all of which can possibly bleed into the finish coat, causing adherence problems, deformation, and staining.

After confirming that the substrate is healthy, **Surface preparation** typically involves removing previous application residues and mending defects, such as patching cracks, dents, and other surface irregularities. For drywall preparation, depending on level of application, seams and fasteners are coated. Typically, **joint compound** is used for patching and filling, spackle is a different product and used for small patching jobs. **Skim coating** is a way to create a consistently flat and smooth foundation for paint application. It is achieved by applying a layer of joint compound and smoothing with a skimming blade. If the substrate features an undesired texture, substantial flaws, or it belongs to a wall that is expected to receive grazing lighting, skim coating is a necessity. After the filling compounds are cured, the surface should be sanded with increasingly finer grit abrasers to achieve a smooth application surface. For some applications, the surface is expected to be coarser for the paint to adhere, for others, maximum smoothness is expected to achieve the best finish with a thin coat. For **wood surface preparation**, moisture content must be balanced with the target environment, cracks, holes and gaps should be treated with wood filler, then surface is sanded. Wood should never be sanded across the grain, this might create highly visible scratches. For metal surface preparation, the first step is cleaning rust and residue from the previous application. Sandblasting is an alternative to manual sanding.

The typical paint application features three layers: ① primer or basecoat, ② undercoat, and ③ topcoat or finish coat. **Primer** is the founda-



Fig.05/15 Skim coating involves a continuous layer of joint compound over finished drywall application.

tion for the subsequent coats, the first layer applied after substrate preparation is complete. There are self-priming finish coats available that negate a primer, but most professional applications would require one. For pale colors white primers can be used; for darker and brighter colors tinted primers are more appropriate, to reduce number of coats and achieve depth.

When ordering materials for a paint job, the designer should consider that primers can cover between 200 to 300 square feet surface per gallon, **around 30% less** than the same amount of paint.

Fresh drywall soaks in liquid and moisture and primers **minimize substrate absorption**, enabling efficient use of paint. It creates a surface for better paint adhesion ensuring consistency of color and sheen. Specialty primers can inhibit mold, rust, and staining, as well as promote adhesion. Oil-based based primers are better at blocking the chemical bleeding from the substrate, which can be a problem for old construction. Primer should always match the paint solvent type. An **undercoat** can prevent moisture and stain seepage from the substrate, may provide extra protection for denting, and creates a tinted foundation for darker colors.

Paint can be applied via brush, roller, or spray. **Brushing** gives better control, results in a consistent, uniform finish, however, application process is relatively slow. **Rollers** can quickly cover large areas, though the details have to be sorted with a brush. It is easier to reach higher areas. The required skill ceiling is relatively low. **Spraying** is another tool to cover large areas, however, skill and experience are a requirement to achieve a consistent application. Spraying does not leave any brush marks, however, coats might be thinner due to the lighter consistency required for spraying, more coats therefore more paint is needed. An inconsistent application might cause drips and globs to occur. In all applications, **masking** wall details is mandatory to prevent brush slip-ups or overspraying. **Textured paints**, sometimes referred to as novelty or faux finishes, boasts visual intricacy achieved by the use of stencils, sponges, special rollers, rags, etc. Such applications require tools, skill, experience, but also a keen sense of composition, rhythm, and visual balance. Considering the time commitment required, novelty and faux finishes can be fairly costly to implement.

Paint is classified as **household hazardous waste** and the transportation, removal, and disposal are regulated at the government level as outlined by EPA. Planning is required when ordering paint. How much paint is required



Fig.05/16 Painting is a messy process, and masking is a requirement for even the smallest job.



Fig.05/17 Textured paints are often applied with specialized or unusual tools, requiring a lot of skill.

should be carefully calculated and leftovers should be expected. Any leftover paint should either be donated or disposed of through hazardous waste collection as well as take back and recycling programs. Additional guidance can be sought from local public works department, waste management centers, and paint retailers. **Paint should never be poured into sinks or toilets** as it will block the plumbing and create water treatment complications, illegal in some states. Painting tools such as rollers, brushes, etc. used to handle water-based paint can be washed into the drainage, though not advisable.

vid.05/03 Video on appropriate paint disposal process.



vid.05/04 Video on lead paint identification and abatement.



Lead was a hugely popular paint additive from 1900 to 1960. In 1978 it was banned from use after the negative health impact was better understood. **Lead-based paint** was present in three-quarters of U.S. homes built before 1978, and even today many of these houses might feature lead paint. The reason behind lead use was to stabilize the paint, increase durability, and resist moisture. Lead paint cracks, peels, and chinks over time, released to the immediate environment, which can be ingested or inhaled. Lead is a known carcinogen, a poisonous neurotoxin, and an endocrine disruptor. It is extremely harmful especially during child development.

It is critical that lead paint is **identified and removed by experts**, or sealed in an approved manner. Any demolition process, or even sanding down a substrate can disturb the present lead and release lead dust, so utmost care and attention is required.



Fig.05/18 Flocked wallpaper is often associated with the Victorian era patterns and aesthetic.

WALLCOVERINGS

Wallcoverings are continuous sheet materials that are intended to be cut into strips, aligned, and adhered to wall surfaces. **Wallpaper** refers to a single type of wallcovering product; the two terms are not interchangeable. In the past the material was just decorative paper whereas today's wallcoverings can be vinyl, foil, cotton, or various veneers. Even though there is evidence of rice paper wall applications by the Chinese as early as 200 BCE. Evidence dates the first use of wallpapers in Europe to 16th century, though wallpapers start to rise in prominence in the 17th century France, thanks to emerging printmaking techniques and formation of guilds. After the industrial revolution, wallpaper became available to people of more moderate means, William Morris's paisley pattern designs garnered public interest. Also popular in this period, **flocked paper** features a raised velvety texture achieved through sprinkling silk and wool particles to an adhesive coated surface. The adhesive is

vid.05/05 Video of a 1963 documentary on wallpaper.



Fig.05/19 Paisley designs were popularized by William Morris, from the Arts & Crafts movement.



















	Water Resistant		Free Match
	Washable		Straight-Across Match
	Extra Washable		Drop/Offset Match
	Scrubbable	$\frac{20}{10}$ in	Pattern Repeat Offset
	Paste the Wall		Direction of Hanging
	Paste the Paper		Reverse Alternate Length
	Pre-pasted		Peelable
	Moderate Light Fastness		Strippable
	Good Light Fastness		Duplex
	Excellent Light Fastness		Coordinated Fabric Available

Fig.05/20 Most commonly used international wallcovering symbols.

applied according to the desired pattern.

Accurate specification of wallcovering products requires an understanding of characteristic properties, which are as follows: **washability** determines the resistance against light cleaning with damp cloth or sponge; **scrubbability**, measured in cycles, determines the resistance against vigorous cleaning with detergents; **abrasion resistance**, is also measured in cycles, determines the wallcoverings ability to withstand rubbing, scraping, and erosion; **stain resistance** determines the material's ability to endure staining from a variety of reagents; **colorfastness** determines the ability to maintain color and resist fading against chemical and mechanical abrasion as well as UV exposure; **blocking resistance** is the material's ability to avoid unwanted adhesion; **strippability** refers to the ability of the wallcovering to be separated from

the substrate as a single piece, without leaving any residue; slightly different, **peelability** refers to a feature where when separated from the substrate, the wallcovering leaves a liner layer behind to be used for new application or can be cleaned with warm water.

The **breathability**, or permeability of a wallcovering is an important concern that determines the possibility of fungal growth on the substrate. Similar to oil-alkyd paints, the trapped moisture might facilitate hidden mold and mildew growth behind the wallcovering. This is especially problematic on the interior surface of exterior walls that are not well insulated. Cold spots due to thermal bridges eventuate condensation points that are much more susceptible to growth. **Micro-venting** enables breathability for otherwise impermeable non-woven products. It is normally invisible, visible only when held before a light source. Woven or breathable wallcoverings are **susceptible to bleed**, where moisture, stains, or adhesives from the backside can bleed towards the front facing of the product. A sealer on the substrate, as well as a backcoating is required to prevent this phenomenon. Applying wallcovering without cleaning up the previous layers of paint or wallcovering might impede breathability and create problems, even when the new wallcovering is breathable.

*The designer should consider that **organic fibers** are food source for micro-organisms and insects. Moreover, they might not be able to sustain dimensional stability with moisture changes. Polymer-based or fiberglass wallcoverings are less susceptible to this problem.*

A typical wallcovering product features three layers: decorative layer, intermediary layer, and backing layer. ①The **decorative layer** features the pattern and relief determining the visual quality; it can feature a transparent wear layer



Fig.05/21 Close-up detail of grasscloth wallcovering.

for improved abrasion resistance. Decorative layer can feature various materials such as paper, fabric, vinyl, leather, metallic foil, wood or cork veneer, or grasscloth. There are several printing methods for applying patterns and textures on wallcoverings – **screen printing** involves several screens with different colors and patterns assigned to them, which are sequentially pressed for a combined impression. **Block printing** is a more traditional technique that involves pressing paint via carved blocks onto the wallcovering. **Rotogravure**, or cylinder printing, involves the wallcovering running through engraved cylinders fed with colored ink. Digital printing provides flexibility, enables previously highly expensive murals at a reasonable price, or custom patterns in short-runs. ②The **intermediary layer** supports the decorative layer both structurally and visually. Lastly, ③the

backing layer that is adhered to the wall surface determining the mechanical performance of the product. The backing layer can belong to one of the three categories: **Paper backing** is more appropriate for light traffic applications. **Woven backing**, often involves a cotton polyester blend for better performance and increased flexibility. Woven scrim backing is lightweight, and Osaburg backing is medium-weight. Drill refers to a heavy-duty backing used for high traffic situations. **Nonwoven backing** allows higher dimensional stability, can be fused with the decorative layer.

Acoustic wallcovering solutions are available with a noise reduction coefficient (NRC) ranging between 0.2 to 0.9 depending on the mounting configuration. Lacking physical depth, wallcoverings are very ineffective in attenuating lower frequencies and they are not intended as stand-alone acoustical solutions by themselves.

According to the standard **ASTM F793**, wallcoverings are classified into 6 categories based primarily on use characteristics, with increasingly higher performance requirements, . **Category I** is decorative applications only. **Category II** covers decorative and medium serviceability applications; some colorfastness, washability, and flame resistance requirements are present. **Category III** covers decorative and high serviceability applications; with some scrubability requirements, good crocking resistance, and stain resistance against a variety of reagents. **Category IV**, also referred to as Type I, is for commercial serviceability, with higher scrubability, abrasion, and tear resistance requirements. **Category V** or Type II is also for commercial serviceability, involves higher performance requirements and significantly higher blocking resistance and stain resistance. **Category VI** or Type III is for commercial serviceability as well, with significantly higher performance requirements. For instance, 1000 cycles abrasion resistance vs. 300 for Category V or 500 cycles scrubability resistance vs. 300 for Category V.

vid.05/06 Video on screen printing custom wallcovering designs.



Between multiple manufacturers, wallcoverings feature a massive selection of patterns. Wallcoverings can also feature tactile patterns, engravings, or metallic effects, etc. **Murals** are large-scale continuous artworks produced and applied as a series of panels. They can depict literal scenes or abstract graphics. For instance, Chinoiserie murals feature patterns that reflect the heavy interest developed towards eastern artwork in the 18th century Europe. Almost every wallcovering manufacturer has a **custom pattern service** with detailed submission requirements. Custom projects can be costly

with increased lead times. Besides a litany of colors and patterns, wallcoverings also provide functionality such as magnetic, dry erase, or whiteboard surfaces.

Pattern matching is a very important concept in wallcovering applications. The major types of pattern matching are straight-across match, random match, and drop match. In **straight-across match**, the pattern matches across the width of each strip as they are aligned throughout a single reference line, typically the ceiling. In **random match**, the pattern does not require any alignment as continuity is not expected. However, achieving a good sense of randomness and balance requires experience and skill on the wallpaper hanger's part. It is possible to rotate and reverse strips to counter visual impact of color and shading discrepancies.

In **drop-match**, the pattern aligns only when one strip is dropped per pattern repetition. Typically the length of the pattern repeat is 18" or 36". Instead of the horizontal axis, a diagonal axis is emphasized. Drop-match results in the most wastage, each vertical strip needs to be continuous. There are two types available: half-drop match and multiple-drop match. **Half-drop match** involves dropping every other strip by half of the pattern length; so for a 36" pattern repeat the drop is 18". **Multiple-drop match** is more complex, involving at least 4 drops before the strip aligns with the first strip. This means for a 36" pattern height stretching 4 strips, each strip should be dropped 9" before the pattern repeats itself on the horizontal axis. Wallcovering should be carefully cut, laid down, and numbered before adhesive application. **Dye-lot number** indicates if a series of wallcovering rolls are printed in sequence or not. This is important to make sure that the colors will exactly match between strips from different rolls, minimizing visual inconsistency.

Wallcovering rolls are priced as a single unit but sold as continuous double units (double roll),



Fig.05/22 Drop matching involves every other strip to be offset a certain amount.

which minimizes wastage. Triple rolls are also available. There are two width alternatives, the narrower type is called European rolls are 20.5" wide with 33' double roll length, covering approximately 55 square feet. And the alternative is the American roll that is 27" wide with 27' double roll length, covering approximately 60 square feet.

WALLCOVERING APPLICATION

Wallcovering application is a fairly straightforward and relatively less messy application, one of the final tasks on a construction site. Similar to paint application, the **irregularities on the substrate would be amplified on the wallcovering surface, including minor imperfections.** This, however, is also tied to the backing type used. Wallcoverings with thicker backing are slightly more forgiving. The substrate needs to be fully sealed before the application, and the seal needs to be fully cured before moving forward. Especially for gypsum board applications, a sealer application underneath the wallcovering is beneficial in the sense that *when torn down, wallcovering can damage the paper facer of gypsum.* The sealer improves strippability of the wallcovering. Wallcovering primer works with the same principles as paint primer, though the formulations are different. Smoothing out the wall, increases the adherence to difficult surfaces, hides the previous colors and stains, makes removing the wallcovering easy.

Wall liner, also known as *paper liner or liner paper*, is a useful barrier for hiding flaws and imperfections on the substrate while providing a smooth surface. It comes in various thicknesses, thinner wall liners are not able to hide flaws. Wall liners, as well as wallcoverings, can

be **pre-pasted**, meaning the backing of the wallcovering features an adhesive layer off the factory, that is activated when in contact with water. Liners are applied horizontal to the wall, underneath the vertical wallcovering strips. Wall liners can also provide a surface to paint on, it is possible to omit the wallcovering layer altogether. Sizing a wall means applying wall size on plaster or over primer. **Sizer** application creates a somewhat slippery layer, helps with sliding and adjusting the wallcovering during installation, also helps with grip and peelability. Before hanging the wallcovering, the stock should be carefully examined for defects such as color bleeding, shading errors, out-of-register colors, ink spots, delamination, etc. The overall job should follow a consistent direction or orientation that complements the space's natural flow and architectural features; patterns should not be clashing architectural details, rather enforce them. There should be no adhesive drips or smears on the wallcovering facing. There shouldn't be any visible air pockets, creases, or wrinkles.



Fig.05/23 Adhesive is being applied on cut strips of wallcovering.

vid.05/07 Video on practical wallcovering application tips.



06

CONCRETE & MASONRY

- *Vocabulary for concrete*
- *Concrete types and application*
- *Terrazzo and installation*
- *Brick types and installation*
- *Vocabulary for natural stone*
- *Quarrying and environmental impact*
- *Stone types and finishes*
- *Stone installation and maintenance*

Concrete is a ubiquitous building material that a mixture of a cementing component, such as Portland cement, fly ash, slag, or silica fume; a mineral aggregate of different fineness such as sand or gravel as filler, and water. The mixture is initially viscous, however, *water causes the cement to harden through an exothermic reaction called **hydration** – not the same as drying by evaporation.* This is also called the curing process, ultimately causing the mixture to harden around aggregates. A key concrete ingredient, **Portland cement** is made by heating limestone and clay to form clinker in a rotary kiln, which is then ground with gypsum into a fine powder. **Fly ash** is a pre-consumer recycled waste of coal-burning process; less common, the manufacturing process unknowns can cause quality variations and unpredictability. Ancient Romans were the first to utilize cement in construction, as early as the 3rd century. Written in the 1st century BC, Vitruvius talks about concrete and mixture proportions in his treatise



Fig.06/01 The dome of Pantheon showcases the capabilities of concrete as a construction material.



Fig.06/02 Portland cement factory. The long tube diagonally running left to right is the kiln.

on architecture. Roman concrete is also known by the name *Opus Caementicium*. **Reinforced concrete**, a composite material involving a steel rebar lattice embedded in a concrete matrix, is the most common application in construction and featured in virtually all modern construction projects.

The high temperatures, approximately 2700°F, required to manufacture cement cause **substantial environmental impact**. In addition, the calcination process releases CO₂ as a substantial byproduct. The total output from the process accounts for almost 8% of total man-made CO₂ production per year. The limestone and aggregate used to produce concrete needs to be quarried in large quantities. **Quarrying rock** results in significant environmental degradation through air and noise pollution, water depletion, soil erosion, and biodiversity loss. Since concrete is such a common building material, it accounts for a substantial portion

of the construction waste, worldwide. Even though rebars can be fully recycled, only a small percentage of concrete is generally recycled as filler. **Uncured cement** is a known irritant; due to high alkalinity it is corrosive to human tissue. However, after curing it is chemically inert and non-toxic.

On grade refers to the ground level of the building; **below grade** refers to any level below the ground level. Concrete is highly susceptible to moisture absorption and transfer, if the material is in contact with a source of moisture, such as soil, it needs to be carefully insulated, especially if situated below grade. The typical concrete is hydrophilic, meaning it will readily suck any moisture present in the environment. Even slight insulation failures would result in carbonation as well as rebar corrosion over time; causing a reduction in concrete's strength, inducing cracking and spalling. **Efflorescence** refers to the white-colored salt streaks and spots on the

vid.06/01 Video on the cement manufacturing process.



vid.06/02 Video on concrete, cement, and mortar.



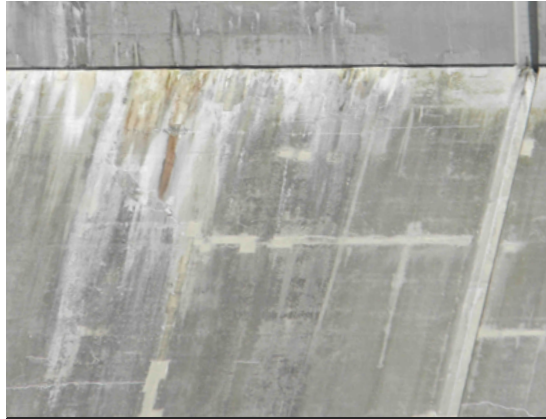

Fig.06/03 Efflorescence refers to the white salt stains indicating significant moisture exposure.

concrete surface, indicating moisture exposure.

Concrete can and should be **tested for the presence of moisture** before any finish application; there are multiple convenient tests available such as on-site humidity probes, calcium chloride test, and digital moisture meters.

There are two common methods for concrete subfloor preparation. **Screed** is a method of topping a horizontal concrete application with a finer coat and leveling the surface either with a flat board or a mechanical tool. This thin top layer features either very fine or no aggregate for a smooth result, as opposed to the thicker base layer, which features larger aggregate size and the outcome is coarse but much stronger. **Float-ing screed** is laid on top of a layer of insulation and does not directly bond to the floor slab underneath. Even though expensive, it mechanically separates two layers and minimizes cracking. **Self-leveling concrete** is another method of achieving a smooth, level finish; this application features a polymer-based additive in the concrete mix and it is less viscous and runnier than the typical screed concrete. The mix is lightly spread with a flexible blade smoother



Fig.06/04 Digital hygrometers are very convenient, though the measurements can be up to 5% off.

while the application slowly levels itself out. Self-leveling concrete is relatively expensive, however, it can be applied as a thinner layer.

Concrete aggregate is fairly brittle when cured and it is subject to dimensional change with shifting moisture and heat conditions. Before the concrete is poured resilient **expansion joints** are placed 10' to 15' apart, around 20 to 30 times the thickness of the slab. It is also possible to saw-cut joints, which should be



Fig.06/05 The screed is a flat board used to straighten freshly poured concrete.



Fig.06/06 Expansion joints are crucial for protecting the integrity of the concrete for extended periods.

done within 12 hours of concrete application. Otherwise, concrete will crack while curing due to contraction.

Besides being commonly used as a structural element and flooring substrate, concrete is also regularly specified as a finish in commercial as well as residential settings. **Polished concrete**, involves sanding the screed or self-leveling concrete overlay with abrasers of incrementally higher grit. Before polishing, concrete needs to be fully cured. This happens typically 10 days after application but in some conditions, up to 28 days are needed. Polished concrete finish has high mechanical and chemical resistance and appropriate for environments with high traffic loads, including forklift traffic. The gloss level can be adjusted; high gloss providing around 0.50 slip resistance and low gloss around 0.60. It is possible to apply polymer coating for higher slip resistance. It is an inert finish that does not degrade and can last many years. **Cement overlays** a thin layer of cement-based product used for repairing, strengthening, and enhancing the look of existing concrete surfaces.

Concrete is a viscous material, before it is cured and needs to be poured in a watertight mold, which is commonly referred to as **concrete formwork**. In order to prevent sticking and ensure



Fig.06/07 Concrete polishers, or floor grinders, feature rotating abraders underneath.

separation while removing a release agent, also known as a parting compound, should be applied inside the formwork. After 2 to 4 days the formwork is removed to let the concrete continue curing. It is possible to use **various admixtures** to enhance or modify concrete's properties. The setting rate can be slowed or curing time can be reduced, possible rebar corrosion can be inhibited, or with plasticizers, concrete can be molded without vibration or compaction, ensuring homogeneous dispersion.

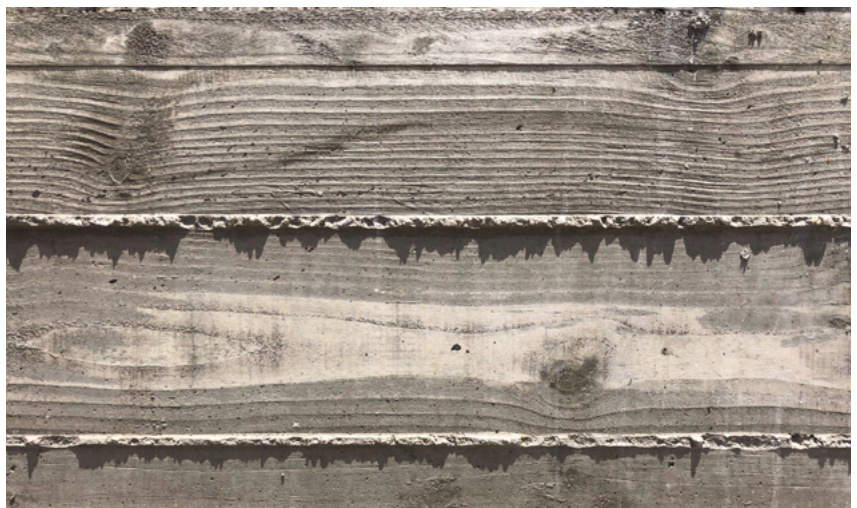

Fig.06/08 Board formed concrete is imprinted with the grain texture of the formwork.

vid.06/03 Video on creating board-formed concrete mock-ups.



Board-formed concrete refers to the process of pouring concrete into a wooden formwork to achieve a characteristic striated look, with the imprint of wood grain. **Wall ties** hold the formwork together while concrete is cured, when removed leaves circular imprints. Glass Fiber Reinforced Concrete allows for the creation of intricate sculptural forms; widely used for DIY furniture. Concrete can be **precast** for rapid construction, reduced labor and waste, and high quality control; can be structural elements, or they can be countertops, furniture, fixtures, or tiles. **Pre-stressed** concrete is great for attaining higher tensile resistance and structural stability.

Terrazzo is a cementitious material that substitutes typical gravel aggregate with chips of granite, glass, porcelain, or any other suitable material of varying sizes. Typically the material receives a polished finish. Cement can be substituted with polymer resin. Terrazzo can be applied either as cast-in-place or sold as precast panels that can be cut into any required shape. Terrazzo tiles are also available in the market.

vid.06/04 Video on a complex terrazzo installation.



Cast-in-place or poured terrazzo is set with brass, aluminum, zinc, or vinyl divider strips, which also function as expansion joints.

Polymer-based terrazzo can be as thin as 1/4" applied directly over the prepared subfloor, a moisture membrane or crack suppression membrane may be required. Monolithic terrazzo is applied at 1/2" thickness, directly over the prepared concrete subfloor. Bonded terrazzo is also 1/2" thick, however, sits on a 3/4" to 1-1/4" mortar underbed. Unlike monolithic terrazzo, bonded terrazzo does not require meticulous subfloor preparation. Lastly, sand cushion terrazzo features a wire reinforcement, sheet insulation, as well as a thick sand layer under the mortar underbed, totaling at 3" application thickness. **The mechanical separation from the subfloor ensures that building settling or deflection of structural elements won't fracture the brittle terrazzo application.**

Terrazzo is renowned for its durability and longevity, and it requires minimal maintenance. It is a popular material for countertops, stairs,



Fig.06/09 Four different terrazzo aggregates: (a) broken glass bottles, (b) unfinished pebble, (c) varying aggregate sizes, (d) large marble pieces.

outdoor furniture, etc. *Terrazzo is an upcycled and relatively environmentally friendly product as **the aggregate chips are repurposed waste or by-products***. Cementitious finishes such as polished concrete and terrazzo are stain-resistant, as long as spills are cleaned and dried quickly. **Highly acidic or alkaline cleaners can damage concrete and terrazzo, nevertheless, diluted hydrogen peroxide or ammonia can still be utilized.**

BRICK

Masonry is a method of building structures or surfaces with units or blocks, such as brick, concrete, or stones, bonded together with mortar, a relatively fine cementitious paste. Masonry units typically manufactured in standard sizes.

Brick is a common masonry unit manufactured by molding clay into forms, drying them, and then firing them in a kiln at high temperatures. The standard brick size is 2-1/4" by 3-5/8" by 8" and weighs around 4.5 pounds. There are many shapes and sizes of brick available such as solid, utility, norman, frogged, hollow; some are for decorative purposes others solve unique masonry problems, such as cornering at a specific angle.

First examples dating back to 7000 BCE, bricks have been a staple building material throughout the world with countless local variations in size, color, and composition. Mud bricks were among the oldest building materials, hand mixed, molded, and sun dried. **Brick veneer** became popular in the 1920s. It is still available in 5/8" thick "flat back" units and 3/4" thick with back geometry. This enabled lightweight decorative applications on wall substrates that appeared



vid.06/05 Video on working as a bricklayer in the 1940s.



Fig.06/10 Constructed in 1420, the masonry dome of Santa Maria Del Fiore in Florence, Italy spans 144 feet.

like load-bearing masonry walls. Frank Lloyd Wright used the material and exploited the effect in many of his projects.

The general use **common brick**, also known as **burnt clay brick** with an untreated surface. It has a reddish-brown color with a porous but flat facing. Common brick is often used for non-structural masonry work. There are many other versions available, one being the **engineering brick** which is used for demanding applications where strength, durability, moisture, and frost resistance are required. A highly versatile option, **face brick**, is manufactured for visual exposure and features a wide range of colors and finishes, including blues, greens, glazed, or distressed options. **Concrete brick** is not the same as cinder block, features two hollowed-out gaps and an aesthetic finish; more appropriate for interior applications. Due to its porousness. **Concrete masonry unit (CMU)** is highly versatile, more strong and durable than concrete brick, and commonly used as a construction material for load-bearing



Fig.06/11 Frank Lloyd Wright's Xanadu Gallery entrance showcases brick's versatility.

masonry. **Compressed earth block (CEB)** is manufactured by compacting damp soil under high pressure into the shape of a brick. It is an environmentally friendly manufacturing method, however, the unit output is fairly low and the end product has fairly low abrasion and moisture resistance. **Rammed earth** involves the same technique, the resulting product is large blocks or entire floors and walls.

Brick boasts have **significantly lower embodied energy** than glass, steel, or aluminum. Brick is a brittle material and there's always some broken ones in every transported batch, on the other hand, thanks to its modular nature breakage is limited to individual units and construction waste is minimized. Also, its **modular nature** enables expressivity and creative visual statements. Even though they are not as durable as new bricks, **reclaimed or antique bricks** can be used for their distinctive character. They are slightly more expensive and significant visual variability should be expected.

Brick can be **bonded in many different ways;**



Fig.06/12 Reclaimed brick features a unique character.

every single one providing different structural properties as well as visual character. Certain bonding methods are associated with different cultures, regions, or eras. **Stretcher** is the long side of the brick, and the bond featuring bricks laid in stretcher courses with only their long sides showing is called the stretcher bond or a running bond. Each course is staggered to the half-length of the brick face. Similarly, **header** is the short side of the brick and only the short side is seen in the header bond. **English bond** is a very strong bricklaying method featuring one stretcher course and one header course in alternation. **Common bond**, or American bond involves a header course between three to five stretcher courses. Flemish bond, involves courses made up of a stretcher and a header in alternation. These are staggered so that the center of the header in one course meets the center of the stretcher on the course above and below. **Stack bond** is somewhat weak and can only be used for decorative purposes, features completely aligned stretcher faces with no staggering.

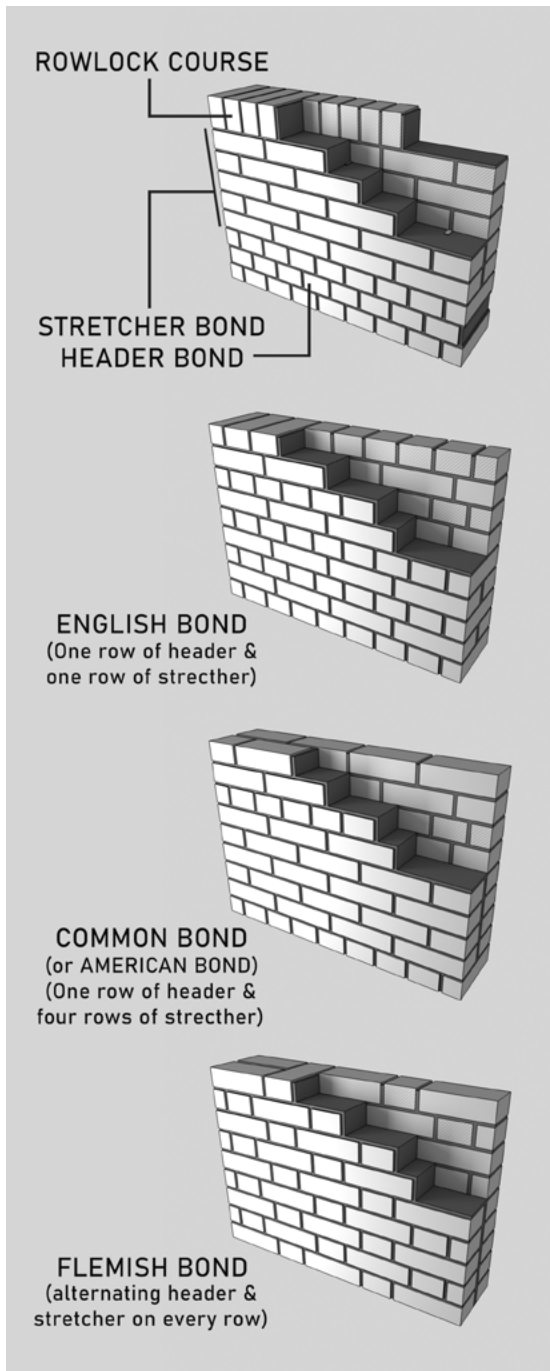

Fig.06/13 A selection of important brick bonding techniques.

Brick provides unique texture, pattern, and relief effects when interacting with light and mortar lines can further elevate the effect. **Mortar lines** can be shaped to influence water-shedding behavior besides the aesthetics; they can be concave, flush, angled, recessed, or extruded. Brick can be painted over for decorative purposes and protection, which can be removed through pressure washing.



Fig.06/14 Brick can be painted over to achieve a more contemporary feel.

STONE

Rock is a naturally occurring mineral aggregate. When rock is removed from its bed for various purposes, it is referred to as **stone**. Stone can be directly used without any processing, or it can be cut, shaped, and, dressed (cut, worked) to create dimensional stone. Stone, alongside wood and mud, shaped early architecture. The earliest constructions often utilized unprocessed stone, boulders, and rubble instead of quarried stone. One of the earliest examples, Skara Brae is a cluster of eight stone houses in a Neolithic village located in Scotland. The Great Pyramid of Giza, built 4600 years ago, is the biggest stone monument today, a testament to the material's strength and durability. Furthermore, natural stone is also highly desirable when aesthetics is a concern, owing to their rich and complex color and texture features. Pietra dura, a technique involving inlaying finely cut, polished colored stones into a stone base, was used extensively in Renaissance Italy.

Natural stone is extracted through quarrying, which involves cutting and removing large blocks of stone from the earth. With the **diamond wire technology operations** sped up and rapidly expanded to previously hard to quarry areas. **Diamond wire technology replaced the feather**



Fig.06/15 Skara Brae is one of the first stone settlements featuring only 8 dwellings.



vid.06/06 Video on how marble is quarried and finished.

and wedge technique, which involves inserting metal tools called feathers into periodically drilled holes on a line on the stone and pushing wedges into the feathers, to force the stone to split. This technique is time-consuming, expensive, and the results could be unpredictable as the stone is essentially split instead of cut.

Depending on how difficult it is to remove natural stone from its bed, its embodied energy can be higher or lower. However, *this is only true for locally sourced stone, as imported stone requires very heavy material to be transported from thousands of miles away, as some desirable colors and textures can only be quarried in specific locations over the world.* For instance, Lava Jewel is quarried in India, or Blue Bahia is quarried in Brazil. **Quarrying** has a significant negative environmental impact. Besides scarring an established landscape possibly causing erosion and destruction of habitat, deeper quarries may affect groundwater flow patterns and quality.



Fig.06/16 The pietra dura technique, developed by Venetians, was extensively utilized in the Taj Mahal.



Fig.06/17 A 1936 photograph from a Maine quarry depicting how the stones were manually processed.



Fig.06/18 The diamond wire needs to be constantly sprayed water to provide lubrication and manage heat build-up.

Depending on a quarry's proximity to various radioactive elements deep underground, radioactive contamination can occur. Consequently, there's a possibility that natural stone used in interiors might emit radon, as well as beta and gamma rays, however, **the radiation is fairly negligible and does not present any danger to the occupants, according to the EPA.**

Petrology is the study of the composition and structure of rocks, their formation, and transformation. Stone is categorized based on how it

was formed. This also determines the hardness of the material. Stones from igneous formations are harder than metamorphic formations which are harder than sedimentary formations. **Igneous rocks** are simply solidified molten magma. Examples include granite, andesite, basalt, pumice, etc. **Sedimentary rocks** consist of tightly compacted sediment such as limestone, sandstone, gypsum, and travertine. **Metamorphic rocks** are formed when the pressure and heat conditions around existing igneous or



Fig.06/19 The Rock of Ages granite quarry is located in Vermont. It is the largest deep-hole quarrying operation in the world, measuring at 600 feet.



Vid.06/07 Video on rock formations.

metamorphic dramatically change and force the rock formation to transform. This last group includes marble, soapstone, and slate.

Fieldstone refers to naturally occurring rocks found on the surface of the soil, rather than being quarried. Requires minimal processing, though labor-intensive to construct with due to random shapes and sizes. Broken bits of stone are referred to as **rubble**. **Pebbles** are small rounded stones. **Tumbled stones** are processed to have rounded edges and a smooth, weathered appearance, mimicking natural wear over time. **Flagstone** is flat stone with naturally split layers commonly used as paving material. **Stone Mosaics** are decoratively arranged small colored stone pieces. **Engineered stone**, or commonly referred to as quartz, is mixture of stone aggregate and resin intense heat and pressure, resulting in a highly durable and non-porous surface. Thanks to its homogeneous resin matrix, it does not require periodic sealing of the surface, unlike its natural counterparts.

The hardness of any stone is expressed by the **Mohs hardness scale**, which is a comparative abrasion resistance test for minerals. The hardness rating ranges from 0 to 10. Materials from

Tab.06/01 Hardness ratings of various natural stones in accordance with Mohs hardness scale.

Rating	1	2	3	4	5	6	7	8	9	10
Material	Talc	Gypsum	Calcite	Fluorite	Apatite	Feldspar	Quartz	Topaz	Corundum	Diamond
Slate										
Marble										
Travertine										
Granite										
Engineered Stone										
Basalt										

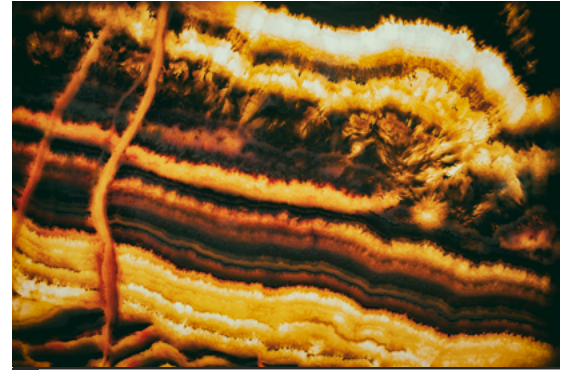

Fig.06/20 The vein structure on onyx results in varying levels of translucency and illumination patterns.

each subsequent hardness rating can scratch the surface of materials belonging to the previous rating. A higher rating means the material is more resistant to abrasion.



Vid.06/08 Video on quartz manufacturing and properties.

Natural stones can be specified for countertops and furniture, panels and tiles are used for finishing floors, walls, and many other architectural elements. **Natural stone is heavy and brittle**, consequently, breakage is a common occurrence. The designer should think about



Fig.06/21 Vein cut texture is linear and layered.



Fig.06/22 Cross cut texture is swirly and cloudy.

how components will be handled and transported to the building site as well as how they will be installed. Natural stone can contain voids, fissures, separation lines that significantly affect workability. The **Marble Soundness Classification** published by the Natural Stone Institute categorizes marbles and granites into 4 groups in relation to the number of holes, voids, and fissures: “rating A” with minimal proportion of geological faults and highest quality, whereas on the other end, “rating D” with the largest proportion of geological faults. Such holes may be repaired by waxing, sticking, or filling with a polymer resin.

Stone slabs are sawn from larger blocks. Typical slab size is around 5’ by 10’, but the actual usable area depends heavily on the source block shape and it is often assumed to be approxi-

mately 45 square feet. The typical slab cuts have 2cm (3/4”) and 3cm (1-1/4”) thickness, custom thicknesses are also possible. Stone slabs can be cut in different ways to achieve different visual effects. **Vein cut** is when the slab is cut parallel to the vein, featuring parallel lines and layers. **Cross cut** is when the slab is cut against the vein, provides a cloudy complex look.

When a block of natural stone is cut, it generates a series of slabs with similar color and texture features. Very similar to how wood veneers are matched, in order to cover large surfaces while maintaining a coherent and pleasing visual whole, various matching techniques can be employed. **Slip matching**, or side slip, involves repeating the same pattern without changing the orientation of the tiles. A very common method, **book matching** involves reversing

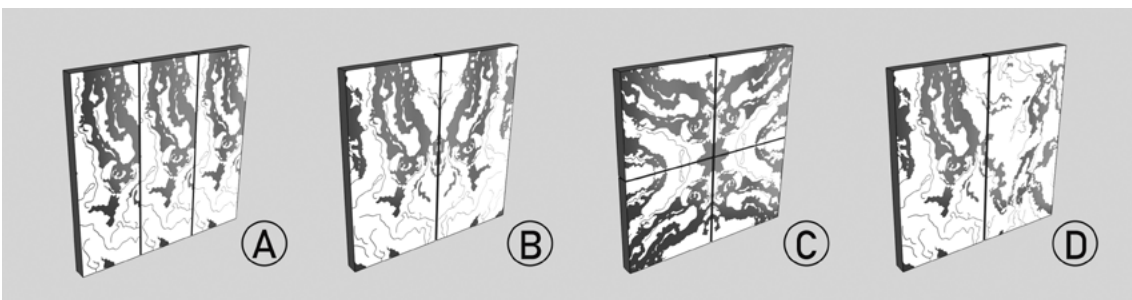

Fig.06/23 Four granite pattern matching techniques are slip (A), book (B), diamond (C), and pattern (D) matching.

one tile to mirror the adjacent tile, resembling an open book. **Diamond matching**, or quarter match, involves 4 tiles mirrored on two axes creating an impression of a diamond shape with their linear vein structure. **Pattern matching**, or blend pattern, involves carefully aligning visual features to create a consistent and continuous visual composition.

*Even though it can create a lot of wastage, for smaller-sized pieces, such as countertops or furniture components, a **specific section of the stone slab can be identified and cut** based on desired vein structure.*

Also referred to as **sawn finish**, stone slabs can be left unfinished after they are cut, which creates a raw, rough, and irregular look. Or, slabs can be further processed to create polished, honed, leathered, etched, frosted, or flamed finishes. A **high-gloss polished surface** can be attained by grinding, honing, polishing and buffing with progressively finer grit abrasers. Denser stones such as marble and granite can achieve a higher sheen compared to sedimentary stones such as limestone or sandstone. Polished granite is high maintenance, requires daily mopping, and regular waxing and buffing. The polish wears off with traffic exposure. Polished stone is often less expensive and readily available. It has poor slip resistance, not appropriate for exterior applications without surface treatment or walk-off mats. Moreover, the reflective polished surface can cause significant glare, especially for darker colored stones. Installation requires extra care as loose sand and grout smears are capable of scratching the polished finish. **Honing** is another type of smooth, yet not glossy finish achieved through grinding and sanding, but with lesser grit abrasers. Visually, it is more understated than a polished finish, though it can hide dirt and smudges; performs well under heavy traffic where cleaning and maintenance is a concern; provides better slip resistance. It is possible to

via.06/09 Video on refinishing polished granite back to honed.



rebuff already polished stone to get a honed finish. **Leathering** is similar to honed granite; it has smooth appearance, but the surface is somewhat coarse and textured. This finish can hide dirt and smudges slightly better than a honed finish but cleaning and maintenance is harder. Requires additional processing therefore slightly more expensive than honing. **Flaming** involves the application of high heat, typically with a blowtorch, to the granite surface, causing the outermost grains to pop and create a rough, weathered texture. Thanks to its prominent texture, this finish hides soiling well and provide slip resistance, though it can affect the natural color of the stone resulting in a darker and duller appearance.

There are two common types of masonry, ashlar, and rubble. **Ashlar** masonry involves finely



Fig.06/24 Ashlar masonry (left) is a stark visual contrast against rubble masonry (right).



Fig.06/25 Natural stone veneers are being thinset on CMU (Concrete Masonry Unit) wall.

dressed stones laid in regular patterns with fine mortar joints. The term ashlar also refers to each of the rectangular masonry units. **Rubble masonry** involves undressed or roughly dressed masonry units, arranged in a seemingly random pattern.

Natural stone can be **placed in mortar**, cement- or polymer-based; or **anchored** to a concrete or masonry substrate. Natural stone is very heavy, between 6 to 10 pounds per square foot, depending on tile thickness. The substrate must be capable of supporting the weight without deflection over time. Depending on the extent of the application consultation and site visit with a structural engineer might be needed. *Natural stone tiles are cut with a **waterjet**, ensuring minimal dimensional difference between each tile.* This enables the grout lines to be very thin, down to 1/16".

Similar to ceramic and porcelain natural stone can be installed on a substrate with a thinset and thickset method. **Thinset** installation requires consistent and meticulous subfloor preparation,



vid.06/10 Video on granite cutting with waterjet.



Fig.06/26 When left to dry, acidic liquids such as lemon juice damages the granite surface.

especially important for polished finishes for consistent reflections. On the other hand, the mortar bed created with **thickset** installation is appropriate when substrate and slab variations are present. Stone slabs can be anchored to gypsum board, masonry, or concrete walls with wire ties or it is possible to install with an epoxy-based thinset adhesive for reliable bonding.

Even though the surface of natural stone appears dense and impenetrable, it is actually porous, especially for the rougher finishes, and it is absorptive. Leftover moisture and food is trapped within the tiny crevices and pores, facilitating bacteria growth. Consequently, there is a need for periodical sealant application. Sealers can be topical or penetrating. **Topical sealers**, such as polyurethane (PU) and acrylic, sit on the surface and wear out quickly and require frequent reapplication. **Penetrating sealers** include silicone and fluoropolymers, which create a stronger bond, however, the finish appears matte, dull, or even foggy if applied improperly. Acids in common food such as dairy, carbonated drinks, alcohol, or even meat can permanently damage the stone if not cleaned immediately. Natural stone with calcite in their composition, such as marble and travertine can stain and etch by acid exposure more readily, especially if its color is lighter.

07

WOOD

- *Vocabulary for wood products*
- *Forest management*
- *Performance properties and behavior*
- *Prominent wood species*
- *Processing and finishing*
- *Wood veneers*
- *Engineered woods*

Within the context of materials and finishes, wood is often used to reference solid wood, however, wood can come in various forms to suit multiple needs of the designer, such as veneer, engineered wood, or it can be processed into thin layers of paper, impregnated with resin, and bonded to form strong dense boards. **Solid wood** is simply lumber cut from trees into boards, planks, studs, or any regular form, which are called dimensional lumber. Lumber is dried in kilns, naturally, or in combination to remove the excess moisture so that when transformed into a structure, furniture, or decorative component, the wood won't distort in response to the environmental moisture. **Veneers** are very thin sheets of wood sliced from lumber, used to laminate other, often more stable or cheaper substrates to incorporate the desirable wood texture without consuming substantially more valuable wood, all the while ensuring high workability and visual consistency. **Engineered wood** refers to veneers, wood dust, chips, or various

mill yard waste bonded together with polymer resin to create a composite product, such as plywood, medium-density fiberboard (MDF), particle-board, oriented strand board (OSB), and cross-laminated timber (CLT).

An important classification for solid woods is the **hardwood vs. softwood** distinction, which simply identifies if the source tree was deciduous or evergreen, respectively. Even though the words hard and soft are mentioned, the classification has little to do with the actual hardness or softness of the wood. For example, Pacific Yew, a softwood, is harder than some hardwoods and Balsa Wood, a hardwood, is softer than many softwoods due to its very low density porous structure. Bamboo is categorized as grass and depending on how it is processed, it can also be harder than some hardwoods.

Like any other category of materials, sustainability is an important consideration when specifying wood. Similar to other materials the overall environmental impact should be considered. Wood has very low embodied energy, easy to process, and local sourcing is often possible as there are many alternative species available for virtually every use. Locally sourcing wood lowers initial energy costs and carbon footprint typically associated with transportation. Designers should avoid contributing to deforestation by

reducing, reusing, and recycling wood and wood products. Despite having superior performance features and unique textures, exotic woods often encourage deforestation, habitat destruction and loss of biodiversity. Designers should be especially wary of rainforest species from Africa, South America, and Southeast Asia.

Wood is a renewable resource as long as good forest management practices are employed.

Forest management refers to maintaining forest health and growth, protecting associated ecosystems while reducing hazards such as wildfires or landslides. Forest management is primarily about conserving the balance of a very complex system, involving activities like controlling various invasive species of trees as they threaten forest integrity, or cultivating younger trees as they sequester CO₂ much efficiently than older trees. Additionally, older trees become more susceptible to disease and rot. The **Forest Stewardship Council (FSC)** is a non-profit organization focusing on sustainable forest management operating throughout the world. If a wood product features a **Chain-of-Custody** certification, it means that from sourcing, to handling, processing, and delivery the wood product meets the standards set by FSC. An FSC label on a wood product should be sought as it means the material is responsibly



Fig.07/01 Oak is a deciduous tree that supplies hardwood lumber.



Fig.07/02 Good forest management practices ensure that deforestation does not happen.

sourced without compromising the integrity of any forests, ecosystems, or local communities. **Programme for the Endorsement of Forest Certification** is another widely acknowledged independent organization promoting sustainable forest management, claimed to be more appropriate for small forest management.



Link 07/01 [Link to FSC's public certificate search.](#)

GENERAL PROPERTIES

The financial and emotional value of solid wood, as well as its usefulness and desirability are linked to the following characteristics: ① natural grain formation, ② dimensional stability, ③ abrasion resistance, ④ workability and finishability, ⑤ weathering.

Visual characteristics, such as the color, texture, and definition of the natural grain formation can vary between different species, between the same species growing in different soil and climate conditions, also, within the same tree between sapwood and heartwood. *The changes in growing conditions year over year determine grain formation, introduces a lot of visual variation.* Lighter rings are called *earlywood* or *springwood* representing fast growth at the beginning of the season and darker rings are called *latewood* or *summerwood* and they are typically denser. The transition between them can be gradual or abrupt affecting performance and workability. Overall, *slow-growing trees with narrower and denser growth rings tend to be harder and stronger than fast-growing trees with wider and more juvenile growth rings.* Another important distinction is the sapwood and heartwood. **Sapwood** is the actual growing part of the



Fig.07/03 Heartwood (cracked core) and sapwood (outer yellowed area) seen on a trunk cross-section.

tree, usually has lighter color and features. As the tree grows, inner sapwood layers go through a chemical transformation and become heartwood, providing structural support for the tree. **Heartwood** is often denser, stronger, and has less moisture content. Trees can endure various outside effects disturbing their natural growth, ultimately creating some unique grain figuring. *This deformed growth is commonly referred to as burl.* The cause may be injuries or virus infection. Insect and animal intervention can cause various figuration as well. *There are also various types of decay that can produce desirable visual results,* such as spalting which is the formation of black lines caused by fungal decay. The visual quality of such deformations is desirable and they are often used as wood veneer. Due to their rarity they are typically expensive.

Being a hygroscopic material, in other words, reactive to environmental humidity, solid wood responds to moisture by expanding and contracting. Wood shrinks or swells most on the tangential direction (across the grain), less on radial direction (approx. 50% less), and neglectable on the longitudinal direction (along the grain). Finished wood will still acclimate and move, and this movement can happen multiple



Fig.07/04 Despite being a growth anomaly, burls have highly desirable visual character and are expensive.



Fig.07/05 Spalting is not a defect but a fungal decay that forms colored streaks.

times within a year as environmental humidity changes. The movement is highly dependent on the species of wood, how it was cut, and if it was dried and acclimatized appropriately or not.

*Bigger lumber pieces are **subject to more movement**, which is one of the reasons for the cracking of lacquers and polyurethane coatings on larger wood planks.*

A log is, in the most basic sense, a cylindrical object that is made up of conical layers of slightly undulating growth rings. Lumber, on the other hand, is a planar product. The sawing direction of the lumber determines the visual and performance properties of the resulting wood product. There are three common sawing methods to

extract lumber: Plain sawing, quarter sawing, and rift sawing. **Plain sawing**, the least wasteful and cheapest cut, involves cutting the log into parallel slices along its length. This method creates the characteristic elliptical grain lines, in some sources referred to as cathedral peaks. The biggest disadvantage, aside from inconsistent grain structure, is that the resulting tangential grains are more susceptible to moisture change, causing further warping. In **quarter sawing**, the log is sawed into quarters, then each quarter is sawn towards the log's center. Grains are parallel on the longitudinal axis, hence there is more dimensional stability and little chance of shrinking and swelling. Lastly, **rift sawing** involves cutting the log perpendicular to the growth rings creating the most consistent parallel grain

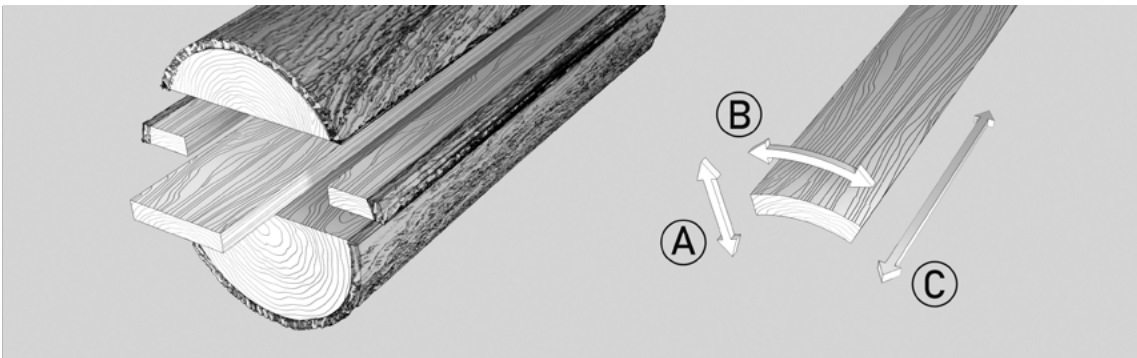

Fig.07/06 Radial (A), tangential (B), and longitudinal (C) dimensions of lumber and warping tendency on radial dimension.

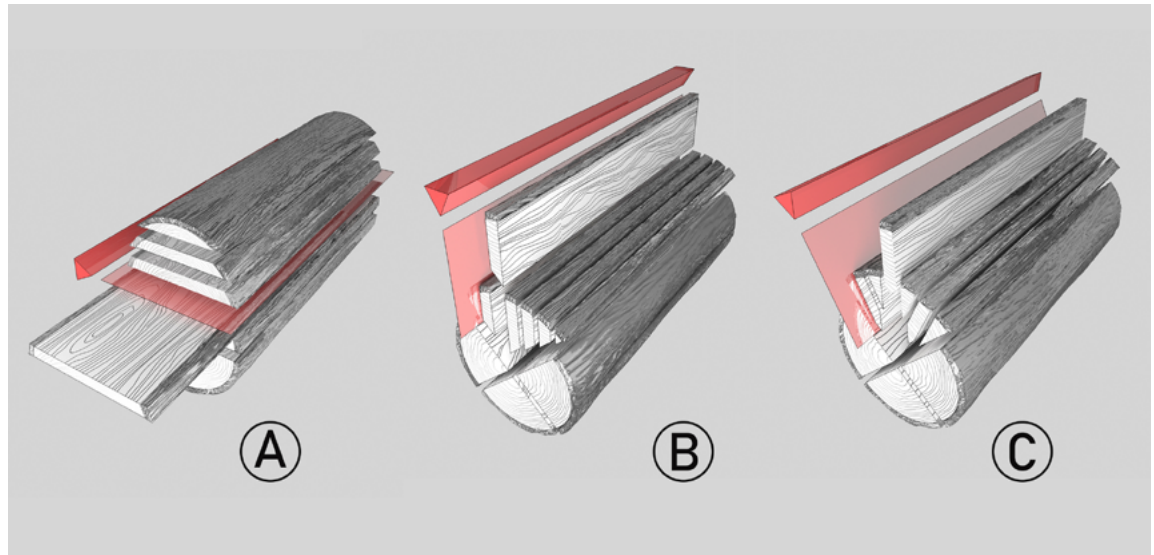

Fig.07/07 Common lumber sawing methods include plain sawing (A), quarter sawing (B), and rift sawing (C).

texture as well as minimizing the possibility of dimensional movement. Rift sawing is often a byproduct of other sawing methods as it causes low yield and relatively useless wedge-shaped wastage between each plank.

The cuts are made in order to obtain wood products useful for a variety of purposes, so it is possible to see multiple types of cuts employed on a single larger log. As an example, for flooring planks (wider than 3”), strips (narrower than 3”), and parquet strips (narrower than 1”, arranged in geometric patterns) are used. Sawmills cut hardwood to obtain the **best yield at a specified thickness**, as a result, pieces of lumber won't have a consistent outline. Hardwood lumber thickness is expressed in quarters – 4/4 means 1” thickness, and 6/4 means 1-1/2” thickness. These are nominal values and actual value depends on if the lumber is rough sawn or planed. In dimensional lumber manufacturing, the word **nominal** means “in name”, which is different from the real value. a 2-by-4 wood stud actually measures 1½ inches by 3½ inches. The principal reason is, when the wood product is **dried, planed, sanded, cured, etc.**, its dimen-

sions become smaller and smaller.

The working properties of different species of solid wood can be found and compared in categories such as machinability, stability, gluing, sandability, nailability, stainability, and paintability. These are often approximations and can vary based on the sub-species, growing conditions, lumber grade, etc. **Hardness and density of a solid wood is also a determining factor for its workability.** The harder the wood is the harder it will be to cut and mill, the blades and tooling



Fig.07/08 A pine log being processed on a modern automated milling machine.

bits will be blunted very quickly. Another important parameter for workability is the **consistency of grains** and the presence of knots, streaks, spots, and other blemishes. These might cause some lumber to split and check during sawing.

The cellular structure of the wood is a significant determining factor in finishability. Some wood species with larger cells have open pores, broad rays, and an **open grain**, has an ability to soak up stains, though in order to achieve a truly smooth finish a filler application may be needed before the topcoat. On the other hand, some wood species have smaller cells, fewer pores, thinner rays, and an overall **tight grain**. These woods are harder to stain, especially when sanded too finely, and pre-stain conditioning might be necessary to prevent an uneven look. The presence of **knots and other blemishes** can be problematic as these can bleed resin or simply create an uneven surface that is harder to finish consistently.

The abrasion and denting resistance of the solid wood product depends on its hardness. When hardness is mentioned in the context of materials and finishes, it refers to the ability of a material to resist deformation under stress or impact. The hardness of various wood species is measured by the **Janka Hardness Rating**, which involves embedding a .44 inch diameter steel ball halfway into a piece of wood and measuring the deformation. This rating is very useful for making comparisons. For instance, when specifying flooring for a high-traffic area, a wood species with a higher hardness rating would perform better against the expected wear and tear.

The species at the top of the hardness scale are usually **exotic woods**, which are expensive and slow-growing but more importantly specifying them would possibly encourage unsustainable wood sourcing practices.



vid.07/01 Video on the Janka hardness test.

Wood can weather, oxidize, develop a patina, and fade. UV exposure affects each species differently. Some wood species develop a desirable tint in a matter of months, and others can bleach and turn gray over the course of a few years. Using UV/Fade resistant protection, such as acrylic-based finishes, would slow the process, but in some cases fails to completely eliminate it. *The designer should always be mindful of how **UV exposure** will affect a material, as it is possible to cause visual inconsistencies over time.* For instance, the wood flooring underneath an area rug won't fade at the same rate as the flooring around it. When the rug is removed, the resulting visual inconsistency might be jarring and undesirable. **Surface finishes can also age and weather.** *In general they dry out and harden in time, cracking and peeling, in addition to darkening or yellowing with dust and UV exposure.*

The National Oak Flooring Manufacturers Association (NOFMA) or currently known as **Wood Flooring Manufacturers Association** has



Fig.07/09 Wood shingles on different facades clearly depict the weathering effect of UV exposure.

established wood quality grades, to help with solid wood specification. There are **4 grades available**, from higher to lower: First and Second (FAS), Select, No 1 and No 2 Common (1C and 2C). **First and Second (FAS) grade** features minimal defects and grain variations, and comes in as longer and wider boards. On the other end, in **No. 2 common grade**, there is considerable visual variation and defects throughout. Common grade is appropriate for utility applications where appearance is less critical, or the design calls for a more rustic look. National Hardwood Lumber Association (NHLA) also publishes a rulebook that contains guidelines for inspecting and grading solid wood products. The identification rules are numerous and complicated, however, the logic is similar to the NOFMA quality grading method.



vid.07/02 Video on hardwood lumber grades.

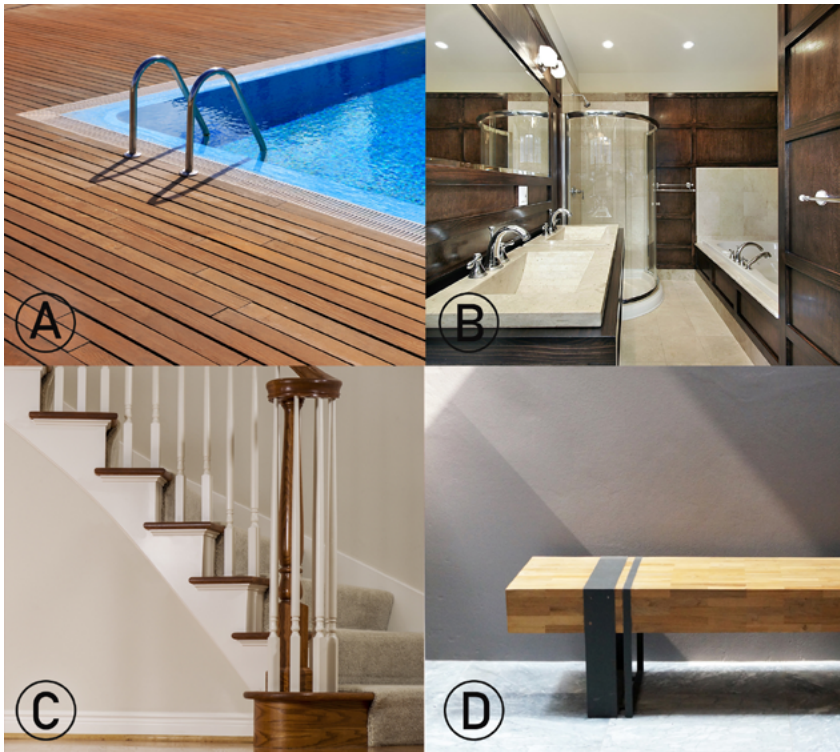

Fig.07/10 Common solid wood applications: flooring – teak hardwood decking (A), paneling – American walnut paneling (B), trims and details – oak stair trims (C), furniture – hickory blockboard (D).

The cost factors for wood are diverse and pricing is determined based on ¹**the type of wood** (type, rarity, supply and demand, transportation), ²**quality/grade** (official grade, size and thickness, treatment and finishes), and lastly, ³**the size/complexity of the job** (includes quantity, skill level, prepwork, installation, maintenance, etc.). *Lumber prices can fluctuate based on various bottlenecks in the supply chain, a %300 increase was observed following the COVID-19 pandemic, in the span of only 6 months.*

Beyond solid wood lumber, the trunk of a tree can supply additional wood resources. The outer bark of the tree is a protective tissue surrounding the vital outer layers of the woody core, which transports water and nutrients along the length of the tree. Besides forming a protective barrier, bark has antimicrobial properties, resistant to decay, especially strong against outdoor conditions, water and moisture, due to its waxy constitution. **Cork** is actually the bark of a species of tree known as the cork oak, mainly grown in Southern European countries such as Spain and Portugal. Properly removing bark requires skill. It is usually done manually, as damaging the inner bark can be fatal for the tree.

Cork is a great thermal and sound insulator, and being naturally impact-resistant, it prevents transmission of vibrations, making it a great underlayment. **Cork** is a **rapidly renewable material**; after harvesting, it regrows within around 10 years. Owing to its structure of millions of microscopic closed air pockets it is resilient, it returns back to its original shape after the pressure is removed. Furthermore, cork cell walls contain a waxy substance, making it **hydropho-**



Fig.07/11 The laborious traditional methods of cork extraction are still widely employed today.

bic, meaning it does not absorb water. The cork panels commonly used in construction are actually grounded and agglomerated cork, whereas the highest quality cork is used as wine bottle

stoppers. Cork is antistatic and antimicrobial; it would inhibit mold growth. Cork can have somewhat random and unpredictable visual features, which can be a blessing and a curse. There are some significant disadvantages to the material, such as heavy objects may leave marks, when subpar binders are used it tends to break into pieces, and sunlight causes fading. When specifying cork under heavy traffic the designer should consider that it is porous and uncleaned spills can cause staining, furthermore, it cannot endure the harsher cleaning products such as ammonia or bleach.

SPECIES

Every piece of lumber features several properties making them suitable for some tasks and unsuitable for others. It is likely to observe property differences **between sub-species** and even between the **heartwood and sapwood** of the same exact tree. There are also many examples of referring to different species with a single name. Such as, oak which actually refers to 30 to 60 different tree species with similar properties, each available in multiple different regions. When considering a wood species, the designer should consider factors such as hardness, strength, dimensional stability, resilience, grain and pore structure, color and texture, workability, maintenance, and of course price range and availability.



Fig.07/12 The color difference between Walnut sapwood (left) and heartwood (right) is dramatic.



Fig.07/13 Hickory heartwood.

HICKORY ● Hickory is a hard, heavy, and strong species, often considered a utility hardwood. The color difference between heartwood and sapwood is distinct, ranging from pale-yellow to dark brown. The texture is uniform and the grain is fairly straight. High bend strength enables shaping around tight curves. Its hardness and density provide resistance against crushing and denting, however, workability is relatively low. Requires sharp tools and quickly dulls edges, though it can be smoothed well and can hold fine details. Hickory is widely available and priced in the low to mid-range.

MAPLE ● Maple is a hard, dense, and strong wood, resistant to wear. Commonly used for flooring. Sapwood is pale yellow-cream and more commonly utilized. Heartwood is reddish-brown, almost mimic more expensive cherry and mahogany, especially with darker staining. It has a fairly consistent texture with faint and closed grain, as a result it stains unevenly. Abundant and moderately priced. There's a hard and a soft maple distinction, which is based on surface hardness difference of around 60% to 100%.

OAK ● Oak is a highly versatile and widely used hardwood species, commonly seen in many residential interiors, making up almost 70% of all hardwood flooring. Sapwood is white to light brown and heartwood is light to medium brown. It has consistent texture and coloration. Owing to



Fig.07/14 Maple sapwood.

the very characteristic open pores, it stains and finishes very well. It features high workability, and moderate dimensional stability. There are two common types, white and red oak. White oak grows slower than red oak, slightly heavier, denser, and durable. Red oak has a slightly reddish-pinkish tint; lighter, cheaper, and more workable than white oak. Northern red oak is commonly used as a comparison standard in the construction industry.

ASH ● Ash is a family of multiple species with similar properties. It features nearly white sapwood, and depending on sub-species, the heartwood can be grayish, creamy, or brown. The grain is straight and open. Black ash has more contrast in grain coloring, tighter grain spacing compared to white ash. Highly workable and steam bend-



Fig.07/15 White oak.



Fig.07/16 White ash.

able. It has relatively high density and hardness. Relatively inexpensive alternative to hickory.

BEECH ● Beech is a dense and hard species with great workability. Commonly used in plywood manufacturing. The texture is somewhat plain with pale tan sapwood and pinkish-brown heartwood. Its grain is straight and moderately tight, however, it is also porous, takes surface treatments well. Somewhat resistant to abrasion and finishes well. Highly suitable to steam bending, used in the construction of famous Thonet chairs. Darkens when steamed. Dimensional stability is problematic and there's considerable shrinking. Widely available and relatively cheaper. Comparable to birch, beech is slightly stronger with more texture definition.



Fig.07/17 Beech sapwood.



Fig.07/18 Yellow birch.

BIRCH ● Birch features a similar appearance to beech, its texture is more subdued and uniform. The sapwood is white to yellow, and heartwood is light to golden brown. Porous, stains and finishes well. It has high workability but due to grain figuring it is also prone to splitting. Carvable and turnable. Relatively flexible with high bendability. Commonly used as veneer, often in plywood manufacturing. There are many iconic pieces of furniture featuring birch plywood. Abundant, widely used, and relatively cheap.

ALDER ● Alder is the softest among widely available hardwoods. Dents very easily, has a smooth and consistent texture. There isn't much distinction between sapwood and heartwood. Normally white to pale-tan, oxidizes to golden-tan or brown



Fig.07/19 Alder.

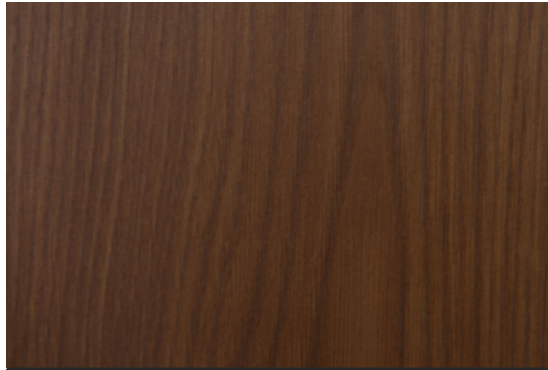

Fig.07/20 Black walnut.

during the drying process. Knots and mineral streaks are not uncommon. Highly workable and machineable. Planes, sands, and finishes well. Commonly used for kitchen utensils, toys, and millwork.

WALNUT ● Walnut sapwood is cream to light brown and heartwood is brown to dark brown with blackish streaks. The very unique and highly desirable color is fairly uniform for sapwood and heartwood separately but there's a dramatic jump in between. It has an open grain structure, the sapwood can be steamed and stained to darken. Dense, hard, with medium to high workability. Carvable and turnable. Planes, sands, and finishes exceedingly well. Resistant to

warping and shrinkage. Resistant to decay and weathers well. Even though a domestic species, considered premium hardwood and relatively expensive. Consequently, popular in veneer form.

CHERRY ● Cherry is another popular premium hardwood. A domestic species, slightly less expensive than walnut. Highly figured and defined grain. Sapwood is pale yellow to light brown and heartwood is reddish-brown. Oxidation and UV exposure causes the wood to quickly develop a darker orange-amber tint. The tree itself is already small, but, due to over-specification only small pieces of lumber available. Fairly stable after drying. Medium to low workability, difficult to stain evenly. Can finish well, though requires significant skill.

MAHOGANY ● Mahogany is a premium hardwood, available only as import. It is listed among vulnerable species. Desirable due to unique visual features; has a tight and interlocked grain structure and shifts color based on viewing angle. Its sapwood is pale pink and the heartwood is reddish-brown. Stains well due to the presence of large pores, finishes exceedingly well. Highly stable, rarely warps or checks. Lighter and softer than walnut and highly workable. Despite being an imported wood it is cheaper than walnut yet more expensive than cherry.



Fig.07/21 Cherry.

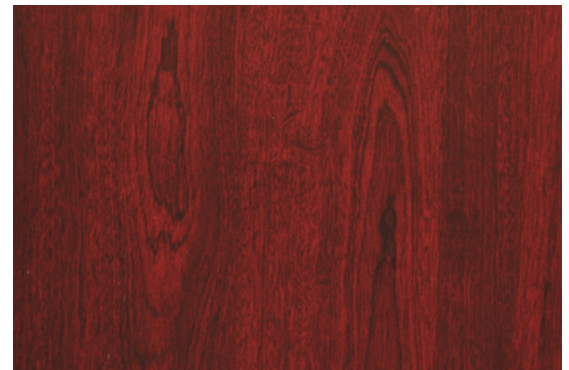

Fig.07/22 Mahogany.

vid.07/03 Video depicting the color shift (chatoyancy) of mahogany.



PINE ● Pine is a softwood with very good performance properties, commonly used as construction lumber. Easy to cultivate, abundant, and relatively cheap. Sapwood is pale yellow and heartwood is golden brown, referred to as heart pine. It has medium contrast in grain texture, and it is fairly recognizable. Depending on the cut it can feature characteristic knots. It has high workability and it can last very long with good protective finish.

DOUGLAS FIR ● Douglas Fir is a softwood obtained from a large growing evergreen/coniferous tree. Due to the size of the tree high-quality knot-free timber can be obtained in long lengths. Moderately resistant against elements, infestation, and rot. It features high workability and dimensional stability. Widely used in construction and can meet demanding performance requirements. Its appearance is distinctive, the heartwood is yellowish-to reddish-brown, and the sapwood is cream, with very pronounced straight grain when quarter sawn. Finishes well.

RED CEDAR ● Red Cedar is another evergreen/



Fig.07/24 Douglas fir.

coniferous tree that is renowned for its natural resistance to moisture, decay, and insect infestation. It is low density, light, and workable. Commonly used in the exterior for decking, siding, and roofing. It is a fairly small tree and the lumber can feature knots, streaks, and other blemishes. Straight grain, pinkish to yellowish in sapwood, purple-red color in heartwood. Has a very distinctive smell.

EXOTIC WOODS ● There are a plethora of exotic wood species available with very unique visual features and outstanding performance properties. Ebony, Rosewood, Zebrawood, Wenge, Teak, and Iroko are some vulnerable and endangered species that have been over-specified and extensively logged. Before specifying an exotic wood, the designer should consult with the lumber



Fig.07/23 Eastern white pine.

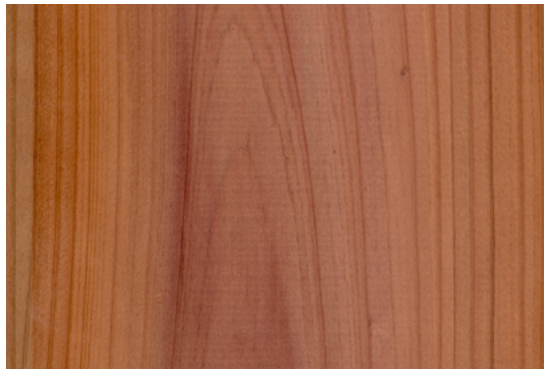

Fig.07/25 Red cedar.



Fig.07/26 Zebrawood.

supplier and consider possible alternatives first. For visual features, **engineered veneers** can be a good, environmentally friendly substitute.

RECLAIMED WOOD ● Reclaimed Wood refers to the wood obtained from dismantled structures or products, often old barns, old casework, shipping crates, or ships themselves. Features a highly desirable weathered look. Even though essentially discarded lumber, reclaimed wood is relatively expensive due to the labor required for sorting, cleaning, de-nailing, planing, sanding, refinishing work. Aside from trusted resellers, it is also possible to directly source unprocessed reclaimed wood, which might have significant defects such as termite damage, warping, dirt, rusted fasteners, and overall inconsistency in quality. Reclaimed wood can be dimensionally stable due to the long time spent acclimatizing. White oak is commonly available as reclaimed wood, however, it is possible to find some wood species that are rare and expensive, such as chestnut. It is possible to find some larger-sized lumber that are not readily available today.

Vid.07/04 Video on working with reclaimed wood.



Fig.07/27 Reclaimed wood.

PROCESSING

All lumber need to go through an initial drying process so that the excess moisture content can be expelled and a balance can be reached. There are two wood drying methods. **Air drying** involves stacking the wood in the open in a way that allows air flow. This is a slow process sometimes taking years, and there's a limit to how much moisture can be expelled. The other method involves drying lumber in large kilns. Known as **kiln drying**, this method is faster and the wood can be dried further, however, it is expensive and various deteriorations such as



Fig.07/28 Lumber drying kiln.

warping and checking may occur depending on lumbers position in the kiln. It is also possible to utilize a combination of both. *Surface moisture content for solid wood has to be 6-9% for interior use, and 9-14% for construction and exterior use.* For different regions, the average equilibrium moisture content differs based on relative humidity. Coastlines such as parts of Florida and California (11%) demand higher moisture content than inland areas (8%), and then there are the arid areas such as parts of Arizona, Nevada, and Utah (6%).

Wood responds to the relative humidity of the environment, and while doing so the material expands and shrinks. This should be considered when specifying solid wood for various uses. Seams, gaps, or kerfing can be provided to accommodate movement, or miter joints might be avoided with wood species that are more susceptible to movement, such as beech or birch.

*When joining wood from different sources (species, heartwood/sapwood, kiln/air dried, reclaimed, etc.) it should be considered that both will **respond differently to moisture** and dimensional change might vary, straining the assembly.*



Fig.07/29 Moisture content of the environment causes the wood to expand and contract.

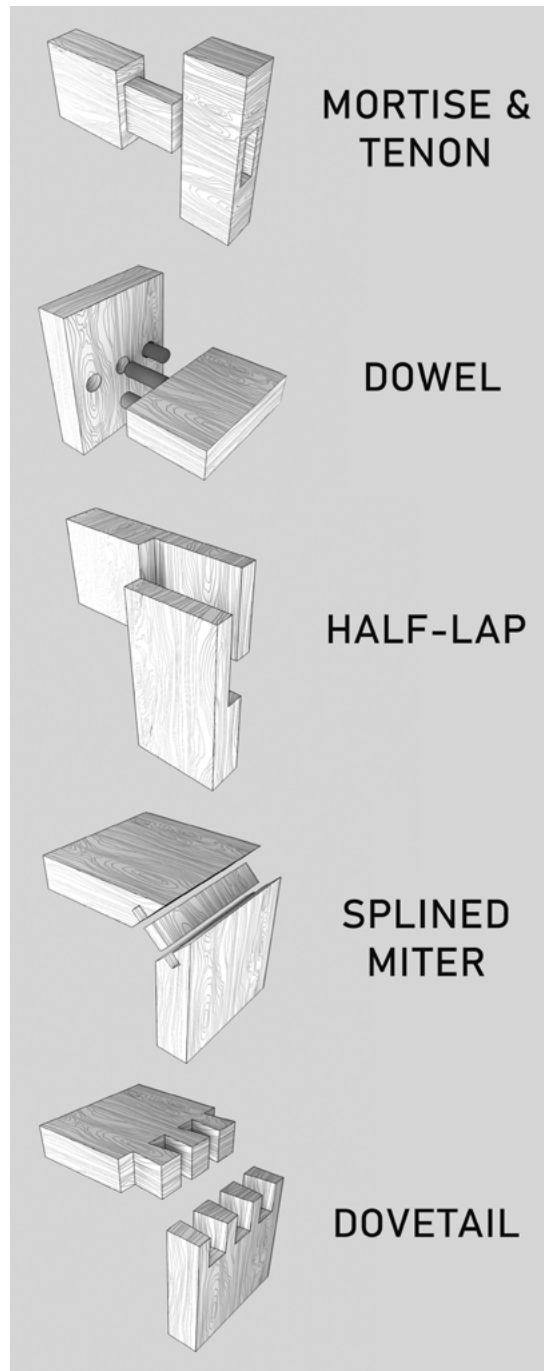

Fig.07/30 Common wood joinery types.

Vid.07/05 Video on the intricacies of drying lumber.



Type of joinery can allow for expansion and contraction without damage to components. An additional important consideration is the **sources of moisture surrounding the wood component**. For instance, when planning to apply wood flooring on concrete, the designer should be wary of the likely moisture draw and should specify details to minimize moisture transfer, such as pads or sleepers. There are various ways to measure moisture in materials, both from the surface and through probing. It is better to write down the required conditions in the initial specification document than dealing with weeks of re-flooring later.

Acclimatization involves placing and aerating the wood in the environment in which it will be installed, so that the moisture content is at an equilibrium before the installation. The time to acclimatize can be between 3 to 7 days, depending on the species of wood and how it will be



Fig.07/31 The preservative use in the pressure treatment provides significant protection but harms the structural integrity of the lumber.

finished. Before attempting acclimatization, the moisture content of the surrounding environment should be already stable. For example, if there's wet paint, it needs to dry or the concrete needs to completely cure first.

It is possible to **treat the lumber** with pressure and heat to achieve protection against moisture-induced deformation, rot, insects, and decay. It is also possible to infuse fire-retardant chemicals to the lumber during the process. It should be noted that pressure treatment and thermal modification are two different processes with different price ranges, performances, and aesthetics. Though not appropriate for most typical structural applications, these products require less maintenance and are often preferred for exterior applications like decking, siding, etc., or when the wood is expected to be in contact with concrete or masonry through which moisture can easily travel. **Treated wood can corrode metals** over time when in contact, a protective coating on fasteners is required. Acrylic Impregnated Wood is another modified wood where pores are infused with acrylic resin throughout the wood, making the wood highly dimensionally stable and moisture resistant.

Solid wood can be finished by one of the many stains, seals, and coatings. **Factory finished solid wood products are available; or wood can be finished in the workshop or on the site.** Even though it is slower, finishing wood later on can be advantageous in terms of fine-tuning and matching color, but some VOC emissions and dust should be expected, and ventilation time should be accounted for before move-in.

Before the application of any finish coating, the wood substrate should be carefully prepared. The wood might contain cracks, wormholes, knots, and the various inconsistencies should be treated with **wood filler**. **Sanding** involves applying progressively higher grit sandpaper to smoothen out the wood surface. Some premium hardwoods such as walnut and mahogany can

receive finer sandpaper well, while others such as Douglas fir and pine, cannot. Sanding should be applied carefully, always along the grain and after the filler is completely dried. The dust should be completely removed following sanding. A **wood conditioner** applied shortly before staining helps open up pores and ensure consistent application.

Wood stain is a solution that deeply penetrates the wood and affects color and grain definition. It can be transparent to enhance the natural visual features or to camouflage the imperfections and inconsistencies on the wood, or anywhere in between. Before applying any coating, water and conditioner can be applied to open up pores. Multiple coats can be applied for better effect. Different types of wood accept stains differently. With its open grain structure oak takes stain well, maple is harder to stain due to its tight grain. On the other hand, for pine, even though it is absorptive, the results would be uneven.

The designer should consider **compatibility issues**, such as water-based vs. oil-based, between each layer of conditioners, stains, and topcoats, as these can significantly deteriorate performance.



Fig.07/32 Sanding should be performed across the grain and never against the grain.

vid.07/06 Video on various wood finishes.



Stains only color or tint the wood and they don't provide protection. Therefore, a protective topcoat is often needed. The most common types of wood finishes are **oil finishes, varnishes, shellac, lacquer, and wax**. It is possible to flame and char the surface of some types of wood to create a unique look that enhances grain patterns. The surface can be further finished with other coatings after the charcoal dust is completely cleaned.

Varnishes are a type of topcoat, often clear, applied as multiple layers of film coating on the wood surface. It isn't absorbed by the wood. It protects and preserves the wood and makes maintenance and cleaning easier. Stains are absorbed and need to be applied before varnishes. Varnish can have a tint and different levels of sheen, down to anti-shine matt. Can be applied with brushes or wiped-on, and some types are available as spray-on. There are different resin-based varnishes with different properties. A water-based acrylic will generate



Fig.07/33 Stains can alter wood's look to such an extent that identifying species requires careful inspection.

fewer VOCs, on the other hand, alkyds are more water-resistant but generate more VOCs. **Polyurethane (PU)** is another type of varnish that is more durable and applied where intense traffic is expected, such as on floors. PU varnish is hard and brittle and it can crack if the wood substrate is not dimensionally stable. Polyethylene (PE), is another such alternative.

Natural oils and waxes are a different class of finishing options. **Oils** can penetrate the surface to an extent but not durable as other applications, they can wear or wash off. **Wax** can be applied as a bare minimum to finish wood or to add sheen and for shedding water. Other finishes won't adhere to wax, so it needs to be cleaned if an additional layer of topcoat is considered. **Shellac** is another similar type of finish that has been in wide usage since the 16th century. It is extracted from natural sources, specifically from the secretions of the Lac bug. It does not feel plasticky and is non-toxic.

Lacquer is a fast-drying coating, similar to varnishes. It is sprayed on in multiple thin layers that slightly dissolve into each other, creating a thick and smooth coating. Can be transparent or opaque, there are also high sheen and matt versions available. Lacquer has a desirable elegant look, though it is not durable. Some types are brittle and crackle over time, especially on larger pieces of wood that deform relatively more.

Depending on the species, wood weathers in unique ways based on exposure to elements and most importantly sunlight. Poor construction and finishing, as well as wear, tear, and damage can result in a distressed and rough look, which may be desirable in some cases. *Most finishes cannot block all UV content in sunlight, allowing for the wood beneath to weather.* Most species of wood will darken first and then turn gray. Cherry wood readily weathers and its color tints over time through exposure to air and light. *Sapwood and heartwood can weather at differ-*



Fig.07/34 Solid wood and veneer can be sanded and refinished multiple times.

ent rates and the color distinction may become pronounced over time. For wood that is expected to be exposed to sunlight, a layer of UV protective finish will be needed. It is also possible to chemically weather wood and quickly develop a patina.

*The designer should consider that, depending on their thickness, solid wood and veneers can be **sanded and refinished** multiple times. Some solid wood and veneers are very valuable and refinishing them saves significant cost while minimizing environmental impact.*

VENEERS

Wood veneers are thinly sliced wood sheets that are applied onto a core panel to be used in furniture, cabinetry, flooring, and paneling. It has been a widely employed method throughout history to maximize surface coverage of rare woods and also to maintain costs. Ancient Egyptians first used hand sawn wood veneers in furniture making in around 2000 BCE. Veneering gained popularity after Renaissance, and with machine sawing techniques developed during the industrialization period, veneer use

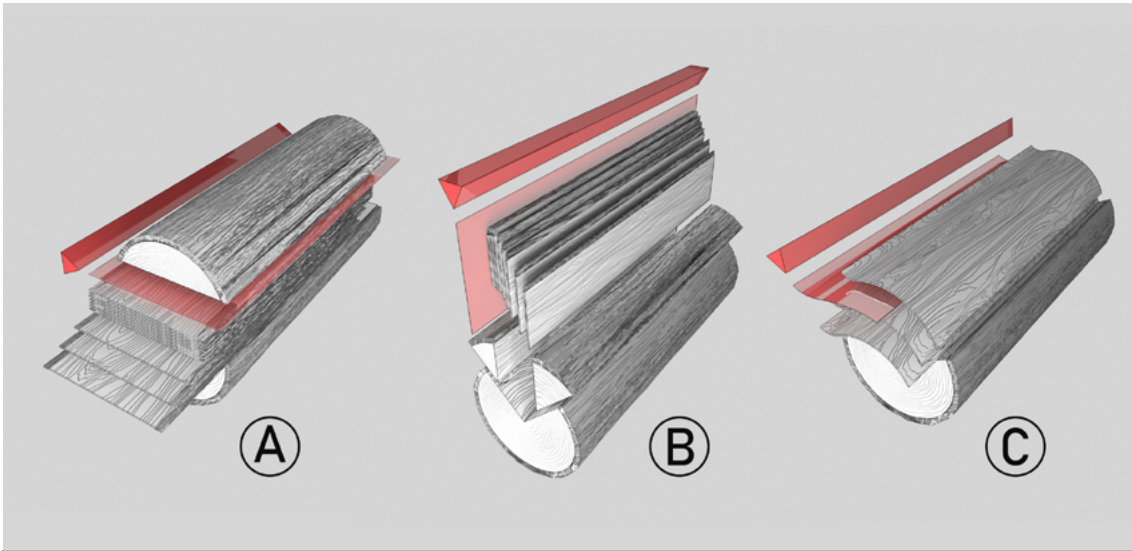

Fig.07/35 Common veneer slicing methods include plain slicing (A), quarter slicing (B), and rotary slicing (C).

became truly widespread. Today, veneer sheets as thin as 0.23 to 0.36 inches can be easily and consistently achieved.

Flitch is a stack or sequence of veneers that have been sliced from the same log and are kept in order. Very much like the way the wood is cut, the way the veneer is sliced ultimately affects the texture. Wood can be sliced around the circumference (rotary peeled) or across the width (straight sliced), each approach resulting in a different pattern. **Rotary peeled** is a good option when sapwood or heartwood consistency is sought after. **Straight sliced**, on the other hand, emphasizes color and grain. Plain slicing or crown-cut veneer will give the familiar elliptical pattern, and quarter-cut veneer will feature a uniform and linear grain structure.

Types of wood veneer include raw, backed, and reconstituted veneers. **Raw veneers** feature no backing and are fully exposed, therefore can be fragile and difficult to work with. Veneers can be of different thicknesses. For example, **shop-sawn veneer** is around 1/8" thick, appropriate for sanding and penetrating finishes, it can

be refinished after a period of use. There are numerous backing options for veneer such as **paper, polymer, fleece, foil, or wood**. The backing imbues the veneer with strength and stability, while potentially improving adhesion to the substrate. Lastly, **reconstituted, engineered, or composite veneers** are manufactured from fast-growing wood species, where veneers are dyed, glued, and re-sliced to create the desired effect. They are an economic and versatile option with high visual consistency.

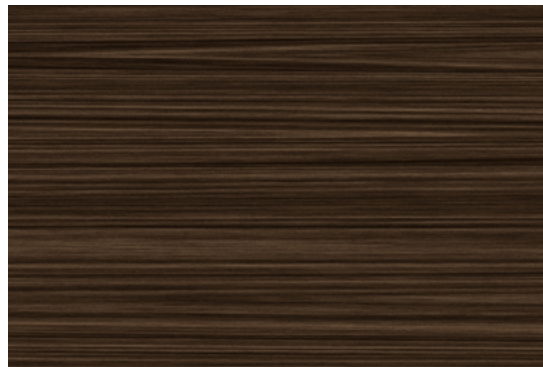

Fig.07/36 Wenge, an endangered exotic lumber, can be easily imitated with veneer reconstitution.

vid.07/07 Video on reconstituted veneer manufacturing.



Using veneers minimizes the overall impact of wood consumption while enabling designers to utilize the much desired appearance of the wood grain. Veneers allow for **expensive and rare woods** to have higher surface coverage. Even though veneers are thin layers and their impact is significantly lower than solid wood, there's still a need for cutting down trees, and high demand for exotic woods can still create environmental repercussions. Another advantage of veneers is that some species and types of wood that would be **unstable and unworkable as solid wood** can be highly workable when affixed to a stable substrate. A prominent example of this is burl wood veneer.

Veneers are typically applied on a **dimensionally stable flat substrate**, such as plywood, particleboard, and medium-density fiberboard. A large variety of adhesives can be utilized in the process, such as PVA, epoxy, contact cement. The process typically requires clamping, and the edges require trimming and sanding. The process is similar to plastic laminate application. Solid wood parts can be incorporated complex details such as edges, corners, and decorative

vid.07/08 Video on wood veneer application.

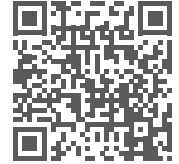

details. Veneer size is limited and sometimes in order to cover large surfaces, veneers are rotated and aligned in an aesthetically pleasing manner, a set of techniques referred to as veneer matching. **Book matching** involves placing two sheets of veneer so that they mirror each other, like an open book. Book matching works well with plain cut veneers creating interesting visuals, though other cut types work as well. **Diamond matching** is similar but the leaf is rotated by 45 degrees and mirrored on 2 axes, creating a diamond-like shape with a pronounced center point. **End matching** is the same as diamond matching but the veneers are not rotated. **Slip matching** involves repeating the pattern, emphasizing the long axis. Slip matching is more appropriate for straight grain veneers, such as quarter sawn oak. In **reverse slip matching**, every other leaf is flipped on the longer axis, creating a flowy look with plain sawn veneers. **Random matching** involves matching, or purposefully unmatching, leaves with random width where seams are highly emphasized. The designer can get very creative and create elaborate patterns, however, this would add to workmanship costs.

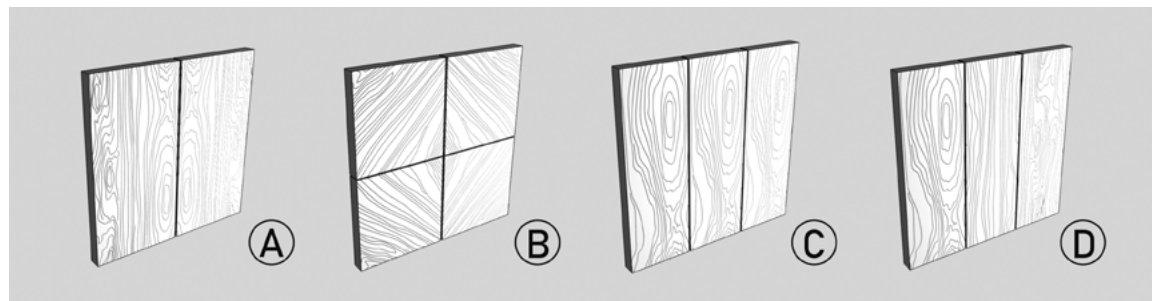

Fig.07/37 Four veneer pattern matching techniques: book (A), diamond (B), slip (C), and random (D) matching.

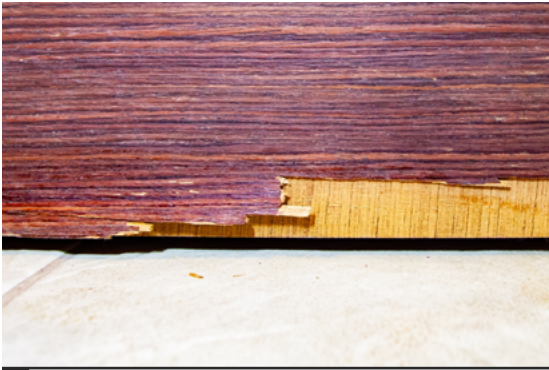

Fig.07/38 Veneer applications can check and peel over time, when exposed to moisture and abrasion.

Solid wood finishing techniques and processes translate to veneers as well, including staining, sealing, lacquering, varnishing, oiling, waxing, polishing. Though, thin veneers cannot be sanded down. The substrate can be highly stable, however, veneers can still crack and peel off. The change in humidity levels or the use of adhesives with high water content might cause the veneer to develop web-like fine cracks, resulting in **checking**, a common and important failure in veneer application.

ENGINEERED WOOD

Engineered wood, also known as wood panel products or composite boards, enable efficient and sustainable use of wood waste. The principal idea is bonding wood veneer, chips, and other wood waste with various plastic resin under high heat and pressure. The strength of the resulting panel is **uniform along the panel**, as knots, checks, shakes, splits, and variations in grain directions and other defects are eliminated. They are highly stable and do not expand or contract with moisture level changes (except particle board), making them more predictable and consistent. They boast high workability. Very much like solid wood products wood panels can be finished with stains, varnishes, oils, lacquers, veneers, and laminates.



Fig.07/39 Shredded wood waste is held together by formaldehyde resin to manufacture particle boards.

There's no need to acclimatize engineered wood products, but ventilation will be needed due to high VOC emissions from the resin component. For fusing the wood content various types of formaldehyde resin are being used, most common ones being urea-, phenolic-, and melamine-formaldehyde. Urea Formaldehyde (UF) used in the manufacturing process emits harmful VOCs to the environment. It is possible to reduce emissions with a careful laminate application or polyurethane (PU) coating. EPA has set standards for formaldehyde emissions from engineered wood panel products, under the Toxic Substances Control Act (TSCA) Title VI. 0.05ppm is allowed for hardwood plywood and 0.11ppm for medium density fiberboard (MDF). Some boards using UF can stay within these emission limits others can't, largely depending on the manufacturer and origin. Alternatives are being researched continuously, polymeric MDI being a promising low-emission option.

Since **leftovers and waste** from other wood manufacturing processes are utilized, engi-

neered woods might seem environmentally friendly, however, processing under heat and pressure results in **high embodied energy** levels, approximately 3 to 4 times more than solid wood. Combined with high VOC emissions, these products can hardly be called environmentally friendly.

Plywood is manufactured by glueing together an odd number, commonly between 3 to 7, of wood layers/plies (softwood, hardwood, veneers, engineered wood) and applying high pressure. Each subsequent layer is cross-laminated for added strength, meaning grain directions are perpendicular to each layer in sequence. There are different types of plywood appropriate for different uses. Structural or sheathing plywood provides better physical performance and their surface is often unfinished. Hardwood plywood is strong, sturdy, and wear-resistant with a desirable grain structure, used mainly for fabricating furniture and casework, suitable where the surface might be visible. The plywood surface can be sanded and finished like other wood products. Similar to plywood construction, blockboards and lumbercore feature a softwood core made up of thicker glued strips, sandwiched between hardwood veneers. There are also various other plywood products that utilize MDF or particle-board as a core, for price advantage without sacrificing aesthetics. Marine plywood is coated with a water-resistant glue to achieve moisture resistance, appropriate for wet spaces where exposure to high humidity is a concern.

American Plywood Association (APA), or currently known (since 1994) as “APA The engineered wood association”, is a non-profit trade organization that sets performance and safety criteria, defines testing procedures, and outlines design standards. APA publishes specific quality grades and ratings for different plywood products and defines their appropriate use. Based on their structural integrity, durability classifications include: exterior, exposure 1, exposure 2, and interior grades which include sheathing, siding,

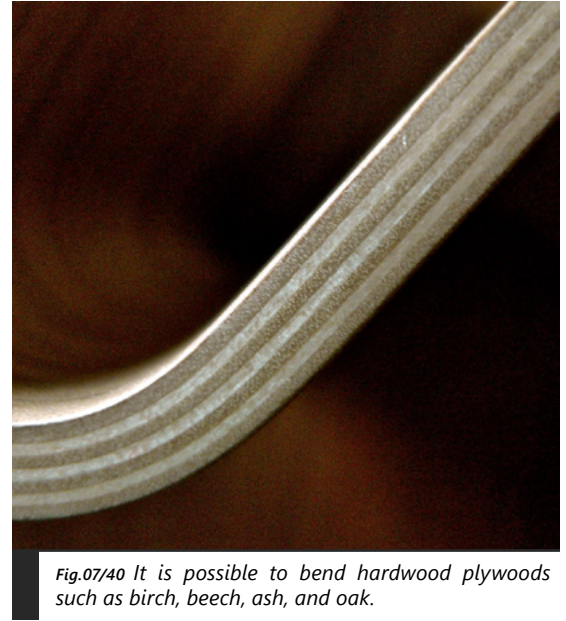

Fig.07/40 It is possible to bend hardwood plywoods such as birch, beech, ash, and oak.

and subfloor underlayment (Sturd-I-Floor). Exterior plywood is manufactured with grade A and B veneer which are free of knot and other defects and have mostly even grain, whereas grade C, C-plugged, and D veneers are used for plywood targeting interior use. All of this can be seen on the APA label on a wood product, along with face grade, thickness, species number, and mill number.

Due to the properties of their adhesive resin, certain types of plywood can be bent using steam or by employing jigs and molds. Birch, beech, ash, and oak veneers can be bent relatively easily. On the other hand, thicker, construction-grade plywoods cannot be bent.

Products such as Wood-Composite Lumber,



Vid.07/09 Video on the manufacturing process of the Eames Lounge Chair.



Fig.07/41 The raw look of the oriented strand board (OSB) became desirable in recent years.



Fig.07/42 The Apple Valley Road Bridge in Lyons, CO utilizes bent GluLam beams as the structural component.

including Glu-Lam, feature layers that are oriented in the same direction, and Cross Laminated Timber (CLT) features layers that are alternated at 90-degree angles; both can span great lengths and support multi-story buildings. Glu-Lam can actually span hundreds of feet, and support greater loads showing similar strength characteristics to pre-cast concrete structural members while being lighter. They can be exposed as they have a unique and desirable look with an already finished surface. There may be some cost savings depending on the fluctuating cost of lumber, though wood-composite lumber products do not perform nearly as well as steel and require more maintenance. It is possible to hybridize the structure and utilize both metal and wood.

Particleboard, also known as chipboard, is manufactured by compressing wood chips, sawdust, and shavings with a synthetic resin, typically urea-formaldehyde (UF), under heat and pressure. They are inexpensive, relatively less durable, susceptible to deformation, especially when moisture is introduced. They are

commonly specified in residential and commercial grade casework, as a substrate for plastic laminates and veneers. Plastic laminate is applied to the surface with contact adhesives, and the exposed edges are later sealed with PVC banding, or in some cases MDF or solid wood trims. There are factory laminated board options available for speeding up manufacturing in the workshop.

Oriented strand boards (OSB) are made of randomly oriented long wood shreds bonded under under heat and pressure using a waterproof resin-wax mixture. Even though largely used as a substrate, exposed OSB became a popular sight in some contemporary interior spaces with an industrial look, such as loft designs.

Vid.07/10 Video on particleboard manufacturing process.



Fibreboards are manufactured from residuals of other wood manufacturing processes, mixed with resin and compressed under intense heat and pressure. Medium-density fiberboard (MDF) and high-density fiberboard (HDF) reside in this category. MDF has a very consistent structure and homogeneous performance properties, often at a cheaper price point than plywood. It has a consistent and smooth surface that can be finished with veneers or plastic laminates, as well as lacquers. Since there are no defects or air pockets in the material, it is highly machinable, interesting relief patterns can be attained with CNC routers. MDX is a waterproof variant of MDF. HDF, also known as Masonite™ or hardboard (lesser versions made with linseed oil), used as underlayment for flooring, substrate, or backboards in cabinetry, or door skins. It is thinner and denser than MDF and manufactured for somewhat different purposes. An important technique for processing fiberboards, kerfing



Fig.07/43 MDF panels can be CNC cut, lacquered, and installed in a sequence to define complex curves.

vid.07/11 Video on kerfing and wood bending.



refers to a sequence of sawblade cuts making their way through the wood close to the opposite surface, to provide bending capabilities. Kerfing can be an alternative to steam bending.

Wood Plastic Composite (WPC) is another engineered wood panel product where only around 15% wood flour is used as a filler, and contain around 70% different types of polymer resin matrices, such as polyethylene, polypropylene, ABS, PVC, polystyrene. They have high workability, can be sawn, bent, or CNC routed very much like other wood products. They are water-resistant, popular for exterior uses such as decking, door or window frames, etc.

08

GLASS & CERAMIC

- *Glass*
 - *History and vocabulary*
 - *Light transmission*
 - *Environmental impact and recycling*
 - *Specification and fabrication*
- *Ceramics and porcelain*
 - *Manufacturing process*
 - *Environmental impact*
 - *Ceramic types and properties*
 - *Specification and installation*

Glass is liquefied and fused sand, at approximately 3090°F, cooled rapidly into a brittle material, referred to as ***non-crystalline or amorphous solid***, meaning it gradually melts instead of at a specific temperature and its internal structure lacks order. Even though its exact composition widely varies, sand is mostly silicon dioxide (SiO₂), which is also known as quartz. When exposed to high temperatures and the impurities are filtered away quartz becomes transparent to the visible light spectrum as well as an important part of the ultraviolet (UV) and infrared (IR) range. *Glass is strong against **compression** and weak against **tensile forces**.* It is possible to use glass as a load-bearing element. Glass can flex to a very small extent depending on the size of the object or panel. It is completely inert and highly resistant to corrosion, does not react to chemicals or permit microbial and fungal growth.

The volcanic rock known as obsidian is considered a naturally occurring glass, and it was



Fig.08/01 Moldavite is formed by the high temperatures created by a meteoric impact.

used for decorative objects as well as weapons owing to its ability to hold a sharp edge. Another naturally occurring glass, Moldavite, was formed by meteoric impact some 15 million years ago. Glassmaking is an ancient craft with evidence suggesting a history extending back to 2000 BCE Mesopotamia. Romans were pivotal in glass manufacturing. They also experimented with different colors and finishes creating decorative items and mosaics.

Stained glass, as a historically relevant technique, involves arranging pieces of colored glass into decorative designs. Traditionally lead comes

are used to join the pieces. Even though there is evidence that variations of **soda-lime glass** has been used throughout Europe for millennia, Venetians made great strides in refining the formula and methodology since the 13th century. It is the most common glass type today and paved the way for many of the relatively modern glass manufacturing techniques.

Plate glass refers to rolled out sheets of glass, grinded and polished on both sides to achieve the desired finish and clarity. This was the primary method of producing large flat panes of glass until it was replaced by **float glass**, a technique that involves floating molten glass on a bed of molten tin to achieve uniform thickness and smooth surface. This process was developed in the 1950s by Alastair Pilkington and has since become the standard method for producing flat glass.

Glass is transparent to most visible frequencies. **Color Rendering Index (CRI)** indicates how much of the visible spectrum can travel through a piece of glass without being filtered. A higher CRI would be an accurate representation of colors and a lower CRI would indicate a significant amount of impurity. A CRI index of 100 is true color, a CRI above 90 is considered good, which can be achieved with standard float glass; low-iron glass has a CRI of 99.7. Glass is denser than the atmosphere and it refracts, or changes the direction of, incoming light waves. This feature can be used to focus or spread light.

R-value indicates the insulation capabilities of a glazing application, its ability to resist heat transfer. Regular glass is transparent to only the short-wave components (800 nanometers, or 800 nm, to 2,000 nm) of the infrared spectrum.

Link 08/01 Link to the Corning Museum of Glass.



vid.08/01 Video on float glass manufacturing process.



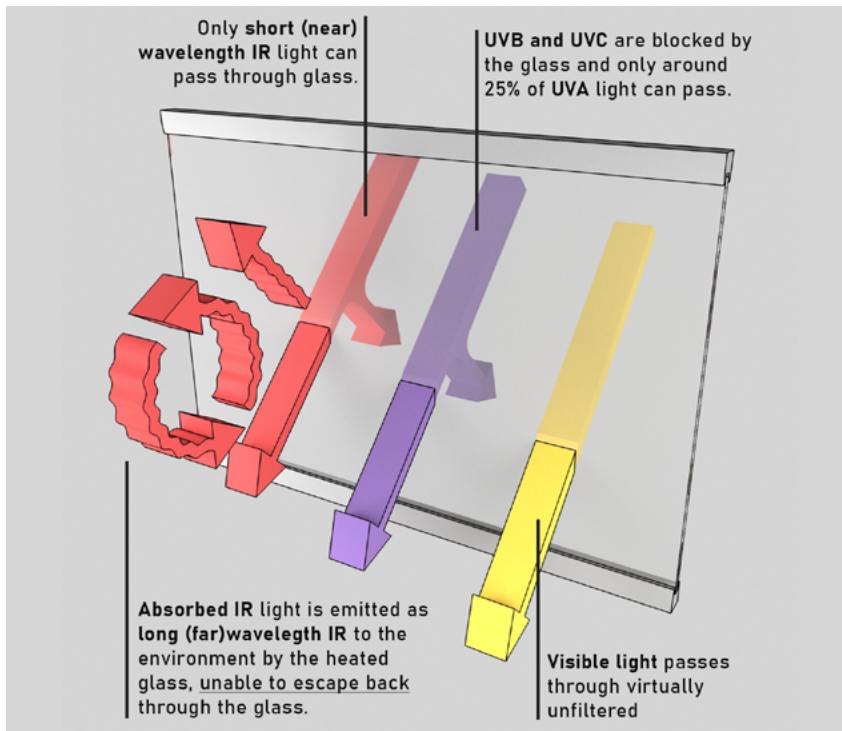

Fig.08/02 Illustration of the greenhouse effect.

However, when struck by long-wave components (8,000 nm to 16,000 nm) glass increases in temperature and re-radiates the heat at long-wave infrared light that cannot exit back and is trapped; which ultimately causes overheating. This is known as the greenhouse effect. **Low emissivity, or low-e, glass coatings can block infrared light as well as minimize radiation.**

Ultraviolet, or UV light is the wavelength range below the visible spectrum between 100 to 400 nm. There are three types of UV-radiation: **UVA**, weaker and not absorbed by the ozone layer, **UVB**, relatively stronger and partially absorbed, and **UVC**, fully absorbed by the ozone layer. UV light is essential for health in short bursts, 15-minute exposure 2 to 3 times a week is recommended by the Center for Disease Control (CDC). However, both UVA and UVB radiation is also a health risk, and along with cleaning

chemicals, a significant cause for material deterioration, weathering, and fading. *Regular glass can block all UVB radiation but only around 25% of UVA radiation. An additional tinted interlayer or UV blocking film is necessary to reduce UV transmittance further.* Even though UVA is weak, it can still cause quite a bit of deterioration. Low-e glass primarily blocks infrared light, but it can also block most of UVA and UVB radiation.

Glass manufacturing process requires intense heat, resulting in high embodied energy and carbon footprint; it is even higher for glass types that require additional processing such as laminated and tempered glass. Furthermore, various harmful chemicals such as sulfur dioxide and nitrogen oxides are produced during manufacturing. Glass is infinitely recyclable, but unlike metals, the recycling process requires the same amount of energy as creating virgin material. The different types of glass should not be mixed together when recycling, it needs to be separated according to chemical additives and impurities. For instance, the float glass of windows and doors cannot be recycled with glass bottles or mirrors. Glass is **chemically inert and non-toxic**. The impervious surface does not require harsh chemicals for cleaning, though the material can withstand them. Glass **does not decompose**, and degrades extremely slowly over the course of many thousands of years.



Fig.08/03 Green and brown glass can only be recycled into new green and brown glass, respectively.

vid.08/02 Video on the intricacies of recycling glass.

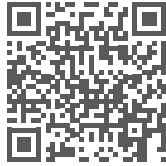

SPECIFYING GLASS

Approximately 90% of glass made today is **soda-lime glass**, which is composed of almost 3/4 silica plus soda ash to lower the melting point and limestone to increase stability and chemical resistance. It is inexpensive, stable, predictable, and highly recyclable. This glass can be modified with additives and is suitable for further processing to tailor it for various uses, such as annealing, tempering, laminating, or many others. **Glazing** refers to the glass panel products that cover building openings or facades. Spandrel glass covers and conceals the structural elements on a full glass façade, in between vision glass that functions as the windows for occupied spaces. A plethora of non-sheet glass products is also available in the market. Glass is extremely versatile in this regard, as it can be molded into tiles and blocks, drawn into tubes, spun into fibers, foamed into insulation, or broken into chunks and used as filler or reinforcement, surface finishes, and decorative components throughout all types of interior spaces.

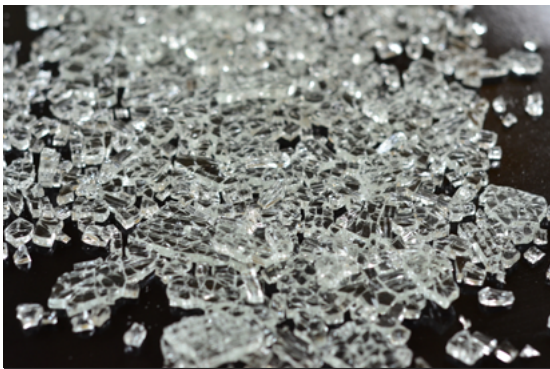

Fig.08/04 Tempered glass crumbles into small pieces instead of large shards, minimizing risk of injury.

Annealing refers to the gradual cooling of glass, that was heated to and hold at a specific annealing temperature. The aim of this process is to reduce internal stress, increasing the durability, impact resistance, and overall performance of the glass panel or component. This process is inherent to float glass manufacturing, as the material slowly cools while it is floating over the tin pool. Glass can be curved through pressing in between two plates at 1150°F. **Tempering glass** involves heating the glass to a critical temperature and rapidly cooling it. This creates internal stress in a specific way so that when met with impact the material crumbles instead of breaking into shards. Annealed glass can be machined, cut, and drilled; however, tempered glass is not workable. The tempering process can be undone by annealing the glass, then it can be worked, and then tempered again. Edges of tempered glass are weaker than the central section of the panel, impact from sides can cause breakage. Low-quality tempered glass with impurities can contain tiny but slowly growing nickel-sulfide accumulations; these can cause spontaneous glass breakage. **Textured glass** is manufactured by rolling the molten glass through patterned rollers. **Wired glass** features a steel wire mesh embedded within the glass during manufacturing. IBC requires wired glass for fire-rated openings, as it can



Fig.08/05 Glass panels can be bend bi-directionally and tempered to cover curved public walkways.

Vid.08/03 Video on spontaneous glass breakage due to nickel sulfide accumulations.



resist higher temperatures, does not explode like other glass types, and can withstand fire hose stream. However, wired glass has low visibility and associated with many safety concerns. Since 2015, wired glass is required to meet strict impact resistance requirements as it had been a significant cause of injury upon occupant impact. **Glass-ceramic** is a fire-rated, impact-resistant, and clear alternative to wired glass, also permitted by IBC.

Laminated glass, also known as safety glass, consists of two or more layers of annealed or tempered glass bonded together with a polymer resin layer. The resin layer can keep shards together when the glass shatters, reducing the possibility of injuries. IBC requires **railing glass** to be tempered laminated glass, to eliminate the



Fig.08/06 It is possible to use laminated glass as load bearing member in less structurally demanding situations such as supporting stairs.

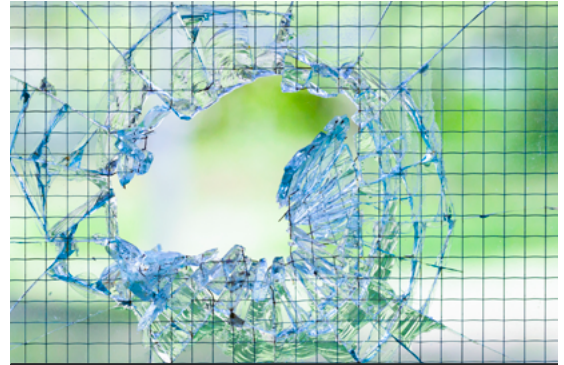

Fig.08/07 Wire glass can be shattered and penetrated by occupant impact, causing significant injuries.

possibility of falling or injury by scattering debris. The only exception is the railing to feature additional precautions to prevent falling and there has to be no walkway below. The bonding resin, or the interlayer, can be either poly-vinyl butyral (PVB) or ethylene-vinyl acetate (EVA). This layer can be 11 mils thick and it can be colored. Most types of glass or polymer panels can be laminated to each other, including acrylic and wire-glass. **Security glass**, as an example for laminated glass, features multiple layers of glass bonded with polymer interlayers, often incorporating polycarbonate panels for added protection and strength. The interlayer is resilient, therefore it reduces the transmittance of sound vibrations, contributing to acoustic separation. The typical window has a sound transmission class (STC) rating of 20 to 30, whereas laminated glass can reach over 40.

Double- and triple-pane glass feature two or three layers of panes, respectively, separated by a vacuum or inert gas-filled space to minimize heat transfer and attain thermal efficiency. 1/2 to 5/8 inch space in between panes is optimal for achieving the highest R-value. Triple pane glass offers an STC rating of 30 to 40. In order to gain better sound attenuation, the distance between glass panes need to be increased which in turn reduces the R-value, therefore the thermal efficiency of the window.

The typical architectural glass contains 0.1% iron-oxide to facilitate the manufacturing process by lowering the temperature requirements. Iron oxide can be in a variety of colors, red, yellow, or blue, depending on its molecular formula (FeO , Fe_2O_3 , Fe_3O_4 are all referred to as iron oxide). The iron oxide used in float glass making process creates a green tint while minimizing light transmittance. The thicker the glass panel, the more apparent the negative effects are. **Low-iron glass** is manufactured by lowering the iron-oxide content. It is suitable when high optical clarity, superior color rendering, increased glass thickness, or simply a clear white/colorless look is required, especially at the edges of a glass panel. For instance, to manufacture thicker security glass without the green tint, or high-end windows to maximize sunlight and clarity of view. **Anti-reflection coating** is a thin polymer film, that minimizes reflections by diffusing and canceling light-rays without impacting clarity or color rendering capability, often used in optical glass. The coating can also be applied on acrylic and polycarbonate. The product is useful for glass display units, storefront displays, or anywhere reflections are a hindrance. The exposed anti-reflection coating lacks durability and chemical resistance, compared to the glass itself, and specific cleaning procedures outlined by manufacturers should be followed. A **mirror**

features a thin layer of highly reflective metal such as silver, tin, nickel, chromium, aluminum, or an amalgam of multiple metals, fused on the polished back surface of a glass sheet. **One-way glass** is actually a semi-transparent mirror, with a thin sheet of aluminum sputtered on one side; the effect is primarily created by the substantial difference of illumination on both sides. In **privacy glass**, a.k.a. **smart glass** or **electrochromic glass**, a small electric current causes a thin electrochromic layer to alter its color and opacity. This enables the glass to instantaneously shift from a transparent state to a translucent state.

During manufacturing various **oxides can be introduced** to the glass mix, as a result the glass selectively absorbs various light frequencies, causing the view behind the glass to appear tinted. For instance, to create a blue tint cobalt oxide is added, while a rich red can be produced by adding gold chloride. These oxides are not the same as paint pigments, they can withstand the high processing temperatures and the resulting color is predictable.

*It is cheaper and more common to apply a **colored polymer resin film** to tint glass, though this is only viable for panel applications.*



Fig.08/08 Architectural glass features a slight green tint due to iron oxide impurities.



Fig.08/09 Some of the more unique and desirable color tints can be easily achieved with a resin film.



Fig.08/10 Translucent vinyl film is a viable alternative to sandblasting and acid etching.

Sandblasting produces a translucent effect by spraying high-velocity abrasive particles against the glass surface. It can be used to add visual richness, make the glass panel more visible, or ensure privacy to an extent. This process results in many small pores on the glass surface, causing the material to hold onto and emphasize dirt, oil, and fingerprints. Furthermore, the sustained abrasion is detrimental to the structural integrity of the glass panel. Tempered glass might shatter after several passes of sandblasting. The same effect can be achieved via **Acid etching** which involves applying hydrofluoric acid on the glass surface. The acid is toxic and highly corrosive to the human body. This process can be applied in layers to achieve multiple levels of translucency, and stencils can be utilized to incorporate interesting graphic elements such as text or logos.

vid.08/04 Video on sandblasting complex graphics on glass.



Light transmittance of acid etching is lower than sandblasted glass, however, the resulting surface is smoother, shows relatively less dirt and fingerprints. Both types require a protective top-coat for preventing smudges and staining. A much more convenient and cheaper method of achieving translucency is applying a **translucent vinyl film** on the glass surface. This provides more control to the designer, however, this layer is not durable and can get damaged over time. Even though relatively more expensive, **fritted glass** can create the same frosted look by fusing ceramic frit to glass during the manufacturing process. The resulting panel can be fully tempered and the surface is more durable and scratch-resistant than regular glass. Since the glass is not abraded, its mechanical performance is not diminished. Highly suitable and common for façade applications.

Glass sheet size is dependent upon manufacturing equipment limitations. 84" by 144" inch panels can be supplied by most manufacturers. Oversized custom sheets would cost significantly more than readily available sheets and lead times should be expected.

Glass is heavy, brittle, and expensive to transport, and lack of **planned and careful handling** can result in breakage. The designer should make sure that there are no scratches and



Fig.08/11 Inconsistent reflections can create a jarring effect.

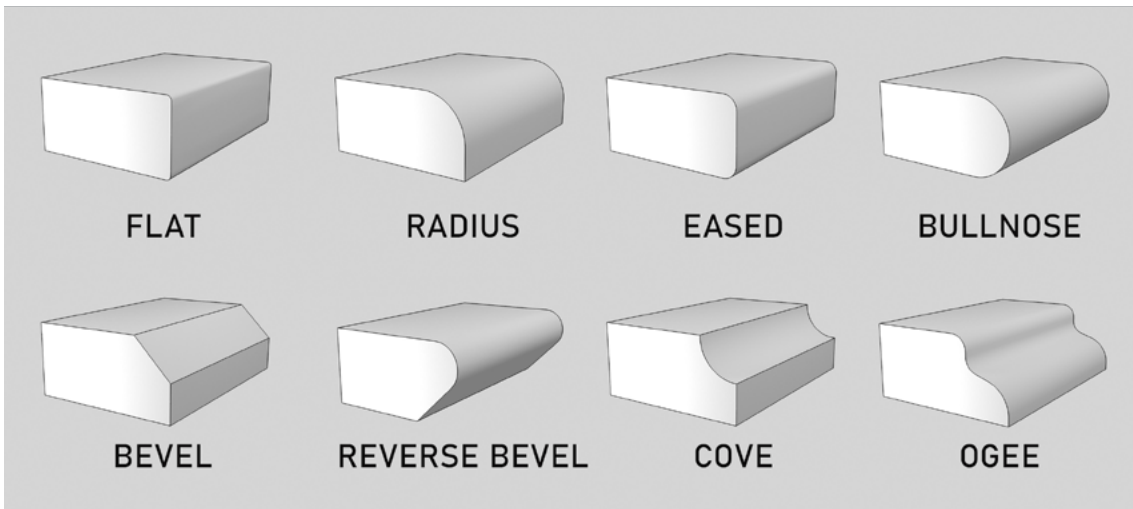

Fig.08/12 The various edge treatment methods used for slab, panel, and sheet products.

defects on glass sheets. Furthermore, glass components need to be checked for alignment to ensure consistent reflections, and smooth operation without friction or obstruction.

It is important to **specify how the glass will interface** with other components. Being a brittle material, glass is sensitive against dimensional change in adjacent materials, which might induce stress. A dimensionally stable backing or intermediary layer such as MDF or plywood minimizes the possibility of shattering. Even though aluminum profiles are widely available, it

is possible to utilize any material with a straight channel, as long as a resilient interface, such as a rubber strip, is provided to prevent cracking; *as the glass will be continuously responding to temperature changes.* Glazing systems can also be suspended from special clamps – e.g. spiders, mullions, and fins. Glass joints can be sealed with urethane or silicone sealants, weatherstripping, and preformed seals, in order to prevent air and water leaks, minimize heat loss, and ensure acoustic separation. **Caulk** is not appropriate for sealing glass as it hardens



Fig.08/13 Glass panels can be suspended with spider fittings, enabling a continuous look without mullions.



Fig.08/14 Glass sealers can dry in the long term, losing resiliency and starting to peel off.

over time and inhibits movement. Dry glazing involves using preformed sealers or gaskets and does not require any curing time. Wet glazing refers to using polymer-based sealants or glazing compound that requires curing time.

Glass has several inherent safety problems, primarily related to poor impact resistance and an ability to form sharp edges. For this reason, lamination and tempering are required by code as upon impact, glass can easily shatter or crumble. In addition, raw edges need to be treated with one of the many types of edging methods to facilitate safe handling. Transparency is another safety issue for glass. The application of **safety squares** or other decorative designs on larger glass panes improve visibility and minimize the risk of occupants running into the material.



Fig.08/15 Safety squares improve visibility of glass panels, useful where occupant impact is a concern.

CERAMICS & PORCELAIN

Ceramics as a category comprise a wide array of different materials, including structural ceramics, refractory ceramics, white-wares, technical, and advanced ceramics as well as ceramic composites. Ceramics have a long history stretching back almost 30,000 years, with pottery fragments dating back 10,000 years. In terms of architectural use, glazed bricks were found in the Elamite Temple in Iran, dating back to approximately 1250 BCE. The Islamic architectural tile, precursor to some modern tile designs, started flourishing after the 7th century. Today, depending on their composition and manufacturing method, ceramics can provide high abrasion resistance, non/semi/super-conductivity, high temperature resistance; enabling many uses beyond pottery and tiling.

Ceramics, in the context of design, primarily refer to white-ware, a category of ceramics comprising formed clay products fired in a kiln at high temperatures to modify chemistry and improve performance. This category includes products such as porcelain, terracota, and vitreous tiles. *The manufacturing process of common ceramics involves* ¹*mixing the ceramic body,* ²*pressing/forming/molding,* ³*drying,* ⁴*bisque firing,* ⁵*glazing, and* ⁶*final firing.* Before first firing and drying, the ceramic product is in the fragile green-ware state, with significant moisture content. Firing can be single-stage or involve two separate stages, referred to as monocottura or bicottura. Drying and firing create considerable dimensional change on the clay body.

Glaze is an impervious layer or coating, composed mainly of silica, as well as fluxes, pigments, stabilizers, etc. The glaze is coated on the ceramic body; following the firing process this coating melts and fuses to the ceramic body, forming a non-porous and abrasion-resistant glass-like layer with various physical and visual properties. It can be glossy, matte, textured, it

can boast a decorative layer underneath or it can feature colors and textures itself.

*The main differences between common ceramics and porcelain is use of refined raw materials and **higher firing temperatures** which helps the body to melt and fuse together; they are also called vitrified products.*

3d printing of ceramics is also possible with polymer-derived ceramic (PDC) resin. Ceramics are generally porous and brittle. They cannot withstand deformation and break almost immediately. Ceramic and porcelain tiles are completely fire resistant, do not combust, however, they can crack or shatter at very high temperatures.

*Ceramic tiles have **very high embodied energy** due to multiple high temperature firing sessions. Proximity to raw materials can reduce environmental impact to an extent by limiting the carbon footprint generated via transportation. It is also more feasible, therefore, it is common to see ceramics manufacturing plants near clay pits. In the past, even the proximity of the heat source, such as wood forests, was an important consideration.*



Fig.08/16 Mass-manufactured ceramic products are fired in large kilns.



Fig.08/17 Abstract glazed tiles from Alhambra complex, in Granada, Spain.

*Porcelain tiles and glazed facing of ceramics are **chemically inert, non-toxic, easy to clean,** and can withstand harsh chemicals. Due to some advantageous visual and physical properties lead is still used in small-scale bespoke ceramic manufacturing. For example, Japanese Raku style glazing. These products are not food safe and there's a possibility of lead exposure, especially dangerous for small children.*



Fig.08/18 Gaudi utilized broken ceramic tiles to finish curved surfaces of Park Guell in Barcelona, Spain.

SPECIFYING CERAMICS

There are three major categories of ceramic: earthenware, stoneware, and porcelain. ① **Earthenware** is fired at lower temperatures, porous, coarse, and low durability. ② **Stoneware** is the common ceramic tile, fired at high temperatures, features an impervious glaze. Lastly, ③ **porcelain** is fired at even higher temperatures, very high performance, and often used for sanitary components as well as high-performance finishes.

Water-resistance of a tile is influenced by chemical composition, density, and surface quality. The **vittrification** process involves melting a silicate compound on the fired clay and form glass crystals, ultimately imbuing the material with impermeability.

Paver is a comprehensive term that refers to stone, clay, concrete, and composite flooring tiles, mainly exterior tiles and rugged interior tiles. **Quarry tiles** refer to unglazed clay tiles with a matte finish; can be fired at high temperatures to attain impermeability. Periodic sealing may be needed. **Terracotta tiles** are natural clay tiles with a characteristic reddish hue, fired at relatively lower temperatures. They lack durabil-



Fig.08/19 Contrary to what their name suggest, quarry tiles are actually fired clay.

ity and readily absorb moisture, rendering them inappropriate for wet spaces due to a significant possibility of mold and mildew growth.

Ceramic tiles feature a glaze layer covering the ceramic body. This layer can abrade over time exposing the tile, which readily absorbs moisture either through exposed areas or more likely through aging grout lines. Most ceramic tiles perform poorly under heavy traffic or high moisture exposure. Ceramic tiles feature unique designs, of numerous sizes and shapes, and interlocking methods. The very small ceramic mosaic tiles feature a mesh backing that groups units together in order to simplify the installation process. It is also possible to order handmade or bespoke tiles from artists, though these will have a higher price tag and often unpredictable performance.

For **porcelain tiles**, the raw materials that make up the body, the existence of glaze, and firing temperatures are different; resulting in a product that is much denser, dimensionally stable, abrasion-resistant, and truly impermeable compared to ceramic tiles. These features render porcelain tiles highly effective under heavy traffic loads and extreme moisture exposure, however, the better performance capabilities come with a relatively higher price tag. **Gauged porcelain**



Fig.08/20 The layer of glaze on ceramic tiles is actually thin, can crackle and wear off over time.

tiles are very thin, with a depth of 1/8" to 1/4"; they are relatively lightweight and can be applied with a thin adhesion agent, resulting in a very low profile. The very large gauged tiles of up to 5' by 10' minimize the number of grout lines, improving cleanability and ease of maintenance. However, installation requires significant experience and it is relatively costly. **Color-through, through-body, or true color, are terms referring to a monolithic body tile with visual and performance properties consistent throughout the entire tile.** This means, there is no glaze to wear off of the surface under heavy use. As the tile abrades under dense traffic, simply more tile is revealed.

When specifying ceramic and porcelain tiles, the designer should consider three separate performance values: water absorption performance, abrasion resistance, and coefficient of friction. **Water absorption** is measured via the test ASTM C373, and a rating of non-vitreous (7-20%), semi-vitreous (3-7%), vitreous (3-0.5%), or impervious (less than 0.5%) is assigned based on the rate of absorption in relation to tile volume.

Abrasion resistance indicates the ability of the tile to withstand scuffing and scratching. Higher values indicate better performance under heavier traffic. It is measured with the test method ASTM C1027, also known as visual abrasion resistance. Accordingly, the tile is given a class rating of heavy commercial (V), medium commercial (IV), heavy residential/light commercial (III), residential (II), light residential (I), and not recommended as a flooring material (O). In some tile specifications, **Mohs hardness scale** is used. On this scale, porcelain tiles typi-



Fig.08/21 Besides the common rectangular form, ceramic tiles can be manufactured in highly complex shapes with relief effects, enabling creative arrangements.

cally perform between 7 to 9 and non-vitreous ceramic tiles are between 5 to 7. For commercial applications, a value of 7 or more is recommended. The **Porcelain Enamel Institute (PEI)** has published their own hardness ratings very similar to ASTM C1027, however only glaze wear is considered; the ratings range between Group 5 indicating suitability for heavy traffic, and group 1 indicating suitability limited to residential environments and vertical surfaces.

Tile Council of North America (TCNA), the related non-profit international trade organization, developed a standardized rating system based on the test ASTM C627, that evaluates floor tile installations with a device called **Robinson Floor Tester**. This relatively simple device applies pressure on the flooring system

vid.08/05 Video on large-format gauged tile installation.



vid.08/06 Video on the Robinson floor tester in action.





Fig.08/22 Slip resistance is a significant factor when specifying ceramic and porcelain tiles.

through three wheels that rotate on a circular path. Based on the number of cycles the system goes through, it is assigned a value according to five performance levels: extra heavy suitable for high impact manufacturing plants, heavy suitable for heavy traffic such as retail, commercial kitchens, etc.; moderate suitable for restaurants and hospitals; light is suitable for offices and reception areas, and residential spaces. **Coefficient of friction (COF)** is tested according to ASTM C1028, indicates slip resistance of a flooring finish. A static COF of 0.6 or less when wet is required for interior finishes and 0.8 or less is required for exteriors. A newer method, dynamic COF is replacing the static version and wet slip resistance of smaller than 0.42 is being required. In these tests 0 means no friction, and 1 means maximum friction, therefore the highest level of safety.

Sorting category, or calibration code, is used to ensure that tiles are both dimensionally and visually consistent. The test ASTM C609 deter-

mines a tile's aesthetic class at 5 increments, from V0 with maximum color and texture consistency between tiles to V4 with substantial color and texture variance.

TCNA publishes a handbook for ceramic, glass, and stone tile installation setting standardized guidelines from substrate preparation to mortar selection. Substrate preparation is very important in tile setting. *The substrate should be sloped to drain water, and the surface should be smoothed out to ensure consistent tile setting. In addition, the substrate needs to be dimensionally stable, completely cured and dry, and should not react to or absorb moisture.* If moisture migration to or from concrete is expected, for instance, for wet spaces or below grade applications, a **vapor barrier** underneath the mortar layer is required. For vertical applications, drywall substrates require water-resistant adhesives and grouts such as epoxy. *Better substrate alternatives are water-resistant "green boards", backer boards, cement boards, or plywood.* However, these might delaminate in time with excessive moisture exposure.

When planning how tiles will be laid, the designer should first think which section would be more visible and which section should be concealed, subsequently focusing on minimizing slivers while trying to align grout lines with spatial features, such as columns, stairs, built-in furniture, windows, etc. *The best method of planning involves placing a "key tile" at the center of the room, loose laying tiles to calculate distances, and sliding the key tile in accordance with the room's features.* If the flooring design involves complex patterns, it is better to correctly draw and specify the tile types, cuts, and locations

vid.08/07 Video on subfloor preparation for tile application.



vid.08/08 Video on tile layout planning.





Fig.08/23 The three steps for tile installation: troweling, laying, and compressing.

before the construction process. Tiles can be equally and consistently spaced by using plastic spacers. Alternatively, there are self-spacing tiles available on the market as well.

Thick-setting involves laying tiles on a thick mortar bed over the substrate. Also referred to as mud installation, this method is great for compensating for unevenness or flaws on the substrate as well as for more flexibility while sloping. It is possible to mechanically separate the mortar bed from the substrate with a membrane, allowing to compensate for the dimensional movement difference between the substrate and the application. The thickness of the mortar bed is around 1" to 2" depending on the specific method. **Thick-setting for wall surfaces must involve a furred metal mesh or ribbed metal lathe** to allow for holding onto enough mortar. Wall tiles are usually 1/4" to 5/8" thick and feature a raised pattern on their backside for better adhesion and stability. Tile applications on walls with cementitious adhesives are not recommended for exteriors, as moisture can seep behind a tile and when frozen, forces the tile to come loose. A much more common tile setting method is **thin-setting**, also referred to as **dry-set mortar**, which involves adhering tiles

to the substrate with a 3/32" fine cement or polymer resin layer. This technique is relatively quick and less expensive, on the other hand, the dimensional movement on the substrate can crack grout lines or loosen tiles. Non-cementitious adhesives, such as epoxy or polymer/latex modified mortars can provide better adhesion, chemical resistance, impermeability, though these can be expensive and somewhat difficult to apply.

An **expansion joint** is a divider strip with a resilient component that can accommodate dimensional movement. These are recommended by TCNA for every tile installation in a gap at the perimeter of the room which can be hidden underneath a baseboard, or for larger rooms, situated at every 12' to 16'. Without expansion joints cracking and tenting can occur. Especially for large format tiles, in spaces with direct sunlight and moisture variations, expansion joints are highly recommended.

The term **grout** refers to cementitious or polymer-based mortars used to fill the seams, or grout lines, between tiles in order to compensate for building movement and thermal expansion, accommodate size variations between tiles and minimize liquid seepage to the substrate.

Cementitious grout mortars harden quickly but they can develop cracks over time. So, a polymer-based filler, such as acrylic latex grout, is a better choice if a lot of building movement or substrate deflection is anticipated. Typical grout space for a ceramic tile is 1/8", usually

vid.08/09 Video on correct adhesive troweling method.



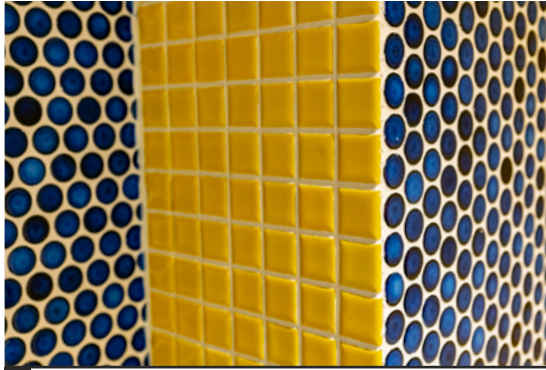

Fig.08/24 Mosaics feature a much higher grouted area compared to other tile types.

this is smaller for porcelain tiles as tile sizes are more consistent. During manufacturing, porcelain tiles shrink in a more predictable manner, consequently minimizing dimensional variability between tiles which can help minimize grout width. However, spacing smaller than 1/16" cannot be properly filled with grout, therefore unfeasible. Large format tiles, which are tiles with one side longer than 15", require at least 1/16" grout space; but manufacturers recommend up to 3/16" grout space to accommodate movement and tile size inconsistencies, which can be more severe for larger tiles.

Besides their functional contributions, grouts are a visual element that can either enhance or deteriorate the aesthetic impact of the tile. **Grout fillers** are available in different colors to introduce contrast and visual interest. **Grout release** is a type of removable surface coating, administered before grout application to protect tiles from staining.

vid.08/10 Video on grout release and grout application.



Fig.08/25 Without the use of grout release, colored grout applications can easily stain white tiles.

Grout lines can facilitate **bacterial and fungal growth**, therefore minimizing the overall proportion of grout lines results in a more hygienic and healthy design solution. Large-format porcelain tiles are better for minimizing grout lines, whereas ceramic mosaic tiles feature the maximum proportion of grout lines. A **grout sealer** can be applied on cured grout to minimize moisture penetration under the tiles. With the exception of polymer-based fillers, grouts expire relatively quickly and require periodical cleaning, re-grouting, and resealing.

09

TEXTILE

- *Textile vocabulary*
- *Environmental impact of textiles*
- *Fiber types and yarn construction*
- *Natural and synthetic fibers*
- *Textile manufacturing and performance*
- *Leather*
- *Carpet construction and types*
- *Carpet installation*
- *Upholstering and soft goods*

Textile refers to either woven or non-woven, flexible sheet products. **Woven** products are networks of fibers constructed via techniques like weaving, knitting, braiding, crocheting, or netting. **Non-woven** products are either hides from animals, compressed or matted fibers, or they are calendered, heat-bonded, or dip-coated polymer sheets. Research indicates that humans started to utilize textiles as clothing between 50,000 to 180,000 years ago. Felt was believed to be the first actual textile besides stiched animal hides. Some early woven textile examples were used to enshroud the dead, found at a prehistoric site in Anatolia. One type of textile gave its name to the Silk Road, and dominated international trade and cultural exchange for centuries. With the industrial revolution, fabric production became mechanized. Consequently textiles became more varied and accessible.

There are three fundamental definitions pertaining to textiles: Fiber, fabric, and textile. **Fiber** is a linear construct with varying cross-sections



Fig.09/01 A colorized cotton mill interior from the 1850s.

and lengths, essentially a basic building block for textiles. **Fabric** is a flexible planar material made through weaving, knitting, or matting fibers. As previously mentioned, **Textile** is a more general term that includes woven fabrics as well as some non-wovens. Textiles can be used for upholstery, window treatments, and finishing interior surfaces. Identification of textiles is controlled through the **Textile Fiber Products Identification Act**, which requires the manufacturer to provide a label containing the manufacturer's name, the country where the fabric is manufactured or processed, generic names and weight percentages of all fibers used, and lastly, the Registered Identification Number (RN). **Association for Contract Textiles (ACT)** is a non-profit organization that represents companies and individuals involved in contract textiles manufacturing, design, and trade as it relates to commercial interiors. The organization's website contains a list of industry-leading textile manufacturers; it has published several voluntary performance and flammability guidelines; the

Link 09/01 Link to the Association for Contract Textiles website.



Fig.09/02 The Textile Fiber Identification Act requires all manufacturers to provide a detailed label.

organization also promotes the NSF/ANSI 336, or the Facts Sustainability Certification program.

Water consumption is necessary for all steps of the textile manufacturing process. It is estimated that each piece of fabric requires the consumption of around 200 times of water in its weight. When the consumption for plant cultivation is added, it is estimated that around 2000 gallons of water is required to manufacture a single pair of jeans. Furthermore, the chemical footprint of this process is also concerning. Especially in developing countries, an absence of government regulations leads to contaminated discharge being dumped directly into waterways. **Closed-loop dyeing systems**, where water is filtered and reused, are proposed to overcome resulting detrimental environmental effects. It should also be noted that, recycling fabrics is a very complicated task and not always feasible.

Blending involves spinning diverse fibers into yarns. It improves performance and cost but complicates reprocessing. For example, it is extremely hard to separate wool fiber from polyester fiber after they are spun together into a yarn.

Textiles are commonly manufactured by following a series of discrete steps. The very first step is fiber production followed by spinning fibers into long continuous yarns, suitable for use during the rest of the fabric weaving process. Following the weaving of the fabric, pre-treatment processes such as washing, scouring, bleaching, or mercerizing can be applied; some of these can also be applied during previous steps. The fiber can be drawn from pigmented pellets, can be dyed in yarn form, or after the weaving process. Then a final finish layer such as glazing or fire-resistant coating can be applied.

Fibers are basic building blocks for most textiles, typically categorized as either natural or synthetic. **Fiber cross-section** is pivotal in determining the performance, appearance, and feel of the overall fabric.

Denier (den, or d), is a fixed-length unit of measurement to indicate the weight and bulk of a fiber. It is the number of grams (0.035oz) per 5.6mi (9km) of fiber. Silk is around 1 den and is commonly referred to as a basis for the denier unit. Microfibers are 1 denier (or 1 den) or less. A strand of human hair is 20 den. A 40 den fiber is very lightweight, whereas a 500 den fiber will

feel heavy and bulky, and over 1000 den is very heavy and bulky. Carpet fibers can vary between 700 den up to 2400 den and are associated with carpet softness and wear resistance. There are various other units to refer to the mass and bulk of a fiber, per determined length, such as “tex”, which is a similar measurement system that is based on the metric system, values are 9 times smaller than denier, despite serving the exact same function. *The thickness can be referred to as yards-per-pound, in the fixed weight system, the lower the number, the thicker the fiber will be.* Over 1500 yds/lb is a fine fiber whereas lower than 500 yds/lb is a bulky fiber.

The bulky fibers mentioned here are actually yarns that feature many fibers twisted or fused together, or unified by some other technique. There are two types of yarns: filament or spun. **Filament yarn** requires very long fibers to be grouped or melted together to create a smooth continuous yarn with a consistent thickness. This method is suitable for synthetic fibers as well as silk. **Spun yarn** involves twisting together shorter fibers, or staples, creating a fuzzy look and softer feel. More suitable for natural staple fibers. *The twisted yarn can be twisted again*

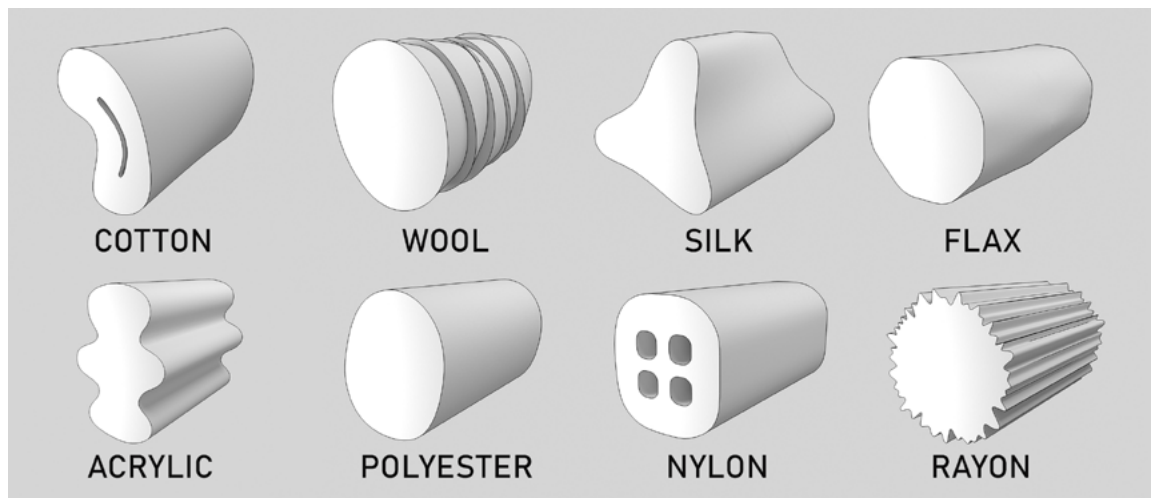

Fig.09/03 Common natural and synthetic fiber cross sections.

with another yarn for added strength, each one referred to as a **ply**. Two-ply yarns are more durable than single-ply yarns. The resulting yarn's denier value will be the total of the denier values of all fibers used in the process. For instance, if two 10 den fibers are twisted together, they would make a 20 den single-ply yarn.

The designer should treat these numbers as a way to compare various fibers and yarns, making sure to **compare the same type of values** between products.

Yarn weight and bulk is only one facet of **wear resistance**; spinning method, weaving method, density, and overall build quality, all factor in to wear resistance of a fabric.

Based on their length, fibers are referred to as staples or filaments. **Staples** are short fibers, up to 30" in length, whereas **filaments** are continuous. All natural fibers are staples, except silk, which is categorized as a filament. Synthetic fibers can be manufactured as continuous filaments with indefinite length. Longer fiber lengths indicate durability and smooth surface quality. Fibers can be naturally **crimped** or they can be artificially crimped before yarn spinning, showing irregularities along the length that improve various performance parameters such as resiliency, stretch, bulk, absorption, and insulation, while negatively impacting appearance parameters such as smoothness and luster.

NATURAL FIBERS

The fibers extracted from plant, animal, and mineral sources are referred to as natural fibers. In order to enhance their properties, they are often combined with synthetic fibers.

Cellulosic fibers originate from the cellulose found in plants such as cotton, bamboo, and hemp. They undergo extensive processing and are regenerated in fiber form. **Retting** is

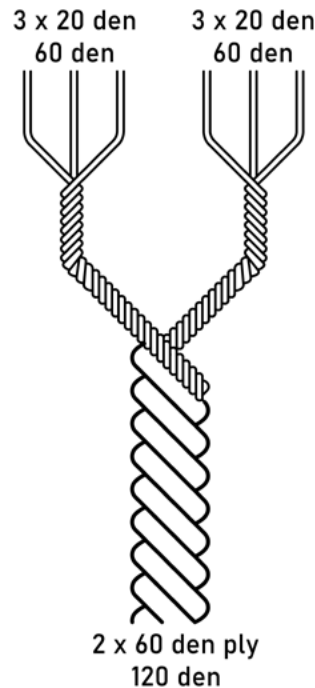

Fig.09/04 A 120 den yarn structure comprising 2 plies with three 20 den fibers.

a process that involves soaking plant stalks in stagnant, chemical-laced water, and decaying the pectin to separate fibers. This category of fibers features high absorbency and low resiliency, biodegradable, and flammable.

COTTON ● Cotton is made from the fuzzy bolls that surround the seeds of the cotton plant. The fiber is soft to the touch, absorbent, and hypoallergenic, commonly used in the apparel industry. It has relatively high durability but is susceptible to UV damage. Even though cotton is a popular and convenient fiber, it has a significant negative impact on the environment. *It requires an*

via.09/01 Video on the steps of manufacturing fabric in a modern mill.





Fig.09/05 Cotton fiber is derived from the fuzzy bolls of the cotton plant, which are pure cellulose.

immense amount of water to cultivate and the **agrochemicals** needed in the process degrade soil and underground water resources.

BAMBOO ● Bamboo fibers are extracted through mechanical or chemical processes, typically utilizing natural enzymes or mild chemicals like sodium hydroxide. It is comparatively softer than cotton, absorbent, breathable, UV resistant, and flexible. Bamboo fiber manufacturing is environmentally friendly in the sense that it does not require irrigation systems or agrochemicals, however, the increasing demand has been causing some deforestation in China and India.

HEMP & FLAX ● Hemp is a durable, resilient, and sustainable substitute to cotton. It is anti-bacterial, and compatible with many other fibers. Used for making linen, flax fibers are relatively less elastic and coarser than cotton, but more absorbent, breathable, and stronger due to longer filaments. Linen does not lint, pill, fray, and crease easily; becomes softer as it is used.

JUTE ● Jute is a coarse and brittle fiber, used in packaging and apparel. In interiors it is used for area rugs, as well as carpet backings. It is very popular in South-East Asia, yet not so much in the Western world. Being a plant-based natural fiber, it is rapidly renewable, biodegradable, antistatic, and hypoallergenic. Finer jute can be



Fig.09/06 Jute is a cheap and durable fiber, yet the yarns are often very coarse in texture.

woven in combination with cotton.

Animal fibers are protein-based natural fibers derived from hairs, fur, as well as secretions of various animals. They are **hygroscopic**, meaning they absorb and retain humidity from the surrounding atmosphere. These fibers require antimicrobial treatment as they are very susceptible to insect attack as well as mold and mildew growth, especially when they are used for carpeting or carpet pads. Animal fibers lose some strength when wet and do not react well to alkaline cleaning chemicals.

SILK ● Silk is a luxurious and somewhat expensive fiber that is generally obtained from mulberry silkworm cocoon, a species cultivated specifically for silk production. Silk is a strong and flexible fiber, exhibits moderate resistance to abrasion and wrinkles, boasts a high sheen and dyes very well. Silk quickly deteriorates, yellows, and fades under UV exposure. It is somewhat fire-resistant, hard to ignite, and burns slowly.

WOOL ● Wool is sourced from sheep as well as other animals such as goat, alpaca, camel, llama, and rabbits. Wool is a common fiber used in interior textiles such as upholstery fabric, drapery, carpeting, and wallcoverings. Wool is lightweight, resilient, flexible, and an efficient insulator. Wool resists combustion and can self-extinguish. Wool



Fig.09/07 The cocoon of the mulberry silkworm is boiled to extract silk fiber, killing the creature in the process.



Fig.09/08 Sheep farming causes considerable amounts of greenhouse gas (methane) release.

carpets are seen as a benchmark for quality; good at hiding soil and provide high appearance retention. Wool, however, can build up a static charge and needs antistatic treatment. *Wool staple length and quality depend on how the sheep are farmed.* Relaxed conditions such as open pastures allow for longer, straighter, higher quality staples; while rocky and rough conditions create a shorter, scallier, and lower quality fiber. **Worsted** is a type of wool yarn that is stronger, finer, and smoother as it is constructed with longer staples; as opposed to **woolen**, constructed with shorter scallier staples, which has the characteristic fuzzy texture that traps air, rendering it insulative and warm.

Even though wool is often referred to as a rapidly renewable resource, **large-scale sheep farming generates methane, an impactful greenhouse gas, can cause deforestation, soil erosion, and water pollution.** Recycling wool is also possible, however, the recycling process results in increas-

ingly shorter fibers and consequently lower quality textiles.

There are many different types of wool harvested from animals other than sheep. **Mohair** fibers harvested from angora goats is one example. Even though expensive, they are also smooth, absorbent, and show relatively high abrasion resistance. **Cashmere** fibers are ultrafine, super soft, and luxurious; harvested from cashmere goats bred for their high-quality fleece.

MINERAL FIBERS • Mineral-based fibers are classified as natural fibers. Glass fibers are formed when glass is melted and extruded into fine strands, they are highly fire-resistant. They are also very brittle and subject to abrasion. Even though the research is not conclusive, there's a possibility that *persisting glass fiber exposure may be carcinogenic.* Asbestos is also a natural fiber that can be woven. Even though it was a fascinating and useful material in the past, today the risks are well understood.

SYNTHETIC FIBERS

Although they were originally developed to replace natural fibers at a lower price point, synthetic fibers evolved to feature many robust and desirable properties not found in any natu-

vid.09/02 Video on the differences between worsted and woolen fibers.





Fig.09/09 PVC fibers are being drawn and spun into spools.

ral fiber. Synthetic fibers can be manufactured from plant-based sources such as wood pulp or totally synthetic sources such as polyvinyl chloride (PVC). Synthetic fibers can be processed to mimic the look and feel of natural fibers, for example, acrylic fiber can be processed to feel like wool, cotton, as well as silk. Synthetic fibers can be heat set enabling them to hold pleats and resist wrinkling. Crimping is also achieved via heat-setting. They are mold, mildew, and insect resistant; most resist ignition, some self-extinguish, but most melt. *One big disadvantage of synthetic fibers is their tendency to **retain static electricity** that can cause light electric shock.* Especially for carpeting anti-static treatment is a necessity. Pilling is another issue for most synthetic fibers partly due to their strength in holding on to abraded lint and partly because of static electricity built up. *Anti-static, flame-resistant, stain-repellant, etc. **additives can be used to augment the performance** of synthetic fibers.* Synthetic fibers are often blended with natural fibers to provide desirable properties and to control costs. For instance, wool is blended with nylon to make an otherwise delicate wool

fabric more elastic and machine washable. Or, a high-end woven carpet can feature wool blended with nylon for high traffic use without sacrificing luxurious feel.

RAYON • *Rayon is the first synthesized fiber, essentially regenerated cellulose (viscose) from refined wood pulp, therefore it is not completely synthetic. The manufacturing process is harmful to the environment and the workers due to high carbon disulfide and sulfuric acid usage.*

NYLON • *Nylon is a thermoplastic polymer, developed by DuPont® in the 1930s as a synthetic replacement for silk. A type of polyamide (PA) itself, Nylon has many variations. For example, Nylon 6 exhibits good performance and high recyclability, whereas Nylon 6,6 exhibits higher performance but is difficult to recycle. Nylon fibers in general have good elasticity, elongation, and recovery. They have low moisture absorption and high abrasion resistance, rendering them very suitable for **carpet manufacturing**. Nylon has low UV resistance.*

ACRYLIC • *Acrylic fibers can be engineered to mimic the look and feel of natural fibers such as silk, wool, and cotton. Acrylic is UV resistant, retains color well, and does not react to harsh cleaning chemicals, therefore appropriate for heavy traffic loads. It can provide significant bulk due to its lightweight and compatible with other fibers.*

OLEFIN • *Olefin, a polymer family that usually reference polypropylene and polyethylene. This fiber is relatively cheap, lightweight, and resilient with good colorfastness. Melts easier than other synthetic fibers. Relatively low static electricity generation, commonly used in carpet manufacturing. It cannot perform as well as Nylon.*



vid.09/03 Video from 1949 on the comparison of nylon and rayon.

POLYESTER ● Polyester is a very popular synthetic fiber commonly utilized in the apparel industry. Strong with great abrasion resistance, dimensionally stable, retains its shape well, and very suitable for crimping. It also retains color and vibrancy well. Polyester has relatively good UV resistance, easier to maintain than many other fibers, and as a result, often blended with other fibers such as cotton, wool, or rayon to increase fade resistance, wrinkle resistance, and washability. A blend of polyester coated with Polyvinyl Chloride (PVC) can offer extra durability and resilience, at a slightly higher price point.

ARAMIDS ● *Aramids are a category synthetic fibers known for their strength and fire resistance.* Kevlar and Nomex are brand names for aramid (aromatic polyamide) type fibers famous for their impact and fire resistance. Woven aramids and other fabrics can be laminated for added performance. **Carbon fibers** are synthesized under intense heat from various polymers such as polyacrylonitrile (PAN) or Acrylic (PMMA). Carbon fibers are woven just like normal textiles and then they are set in resin. The resulting product is a very high strength, lightweight material with high chemical and fire resistance, especially when formed into carbon-carbon composites.

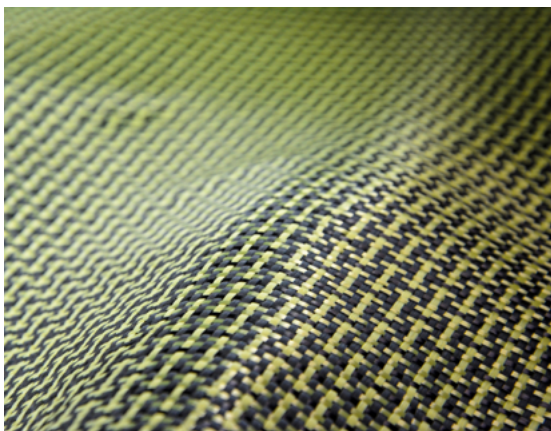

Fig.09/10 Aramids, a fire resistant fiber, can be woven with carbon fiber for increased effectiveness.

MICROFIBERS ● Microfibers are fibers with very fine cross-sections drawn from common plastic resins such as acrylic, polyester, nylon, etc. These fibers retain the properties of the original resin, but they are softer, flexible, can be woven densely. These are popular as cleaning cloths since the tiny extensions on the surface can reach the smallest crevices and hold onto dirt efficiently.

METALS ● *Metals can be expanded, drawn, spun, or cut to fibrous shape and form* **metal fibers**. Similar to other synthetic fibers the fiber profile can be modified to increase strength, durability, flexibility, or appearance. It is also possible to coat metal fibers with a transparent polymer film to minimize eroding and tarnishing. These fibers can be spun with other fibers during yarn manufacturing or can be directly woven into the fabric. Gold fiber has been used to decorate fabrics throughout history. Silver fibers can be woven in to imbue a fabric with anti-microbial and conductive properties. Copper further provides structural support and creasability. Aluminum is a multipurpose and cost-effective alternative to other metal fibers. It is also possible to weave a fabric only with metal fibers. **Metal meshes** with thicker fibers and wide spacing are very suitable for spatial applications.

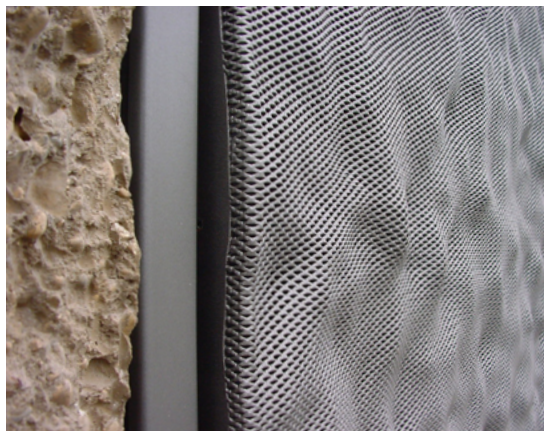

Fig.09/11 A non-woven metal sheet product, expanded metal mesh is able to hold form.

TEXTILE SPECIFICATION

Woven fabrics are manufactured on a loom by **interlacing two or more threads** at a perpendicular angle. These threads, or floats, are referred to as warp (goes up) and weft (goes left). Woven fabric width is determined by the manufacturer based on the capabilities of the looms used; most common widths are between 36" and 60". **Textile hand** refers to the physical feel of the fabric, defining characteristics such as smoothness, drape, elasticity, etc.

The density and type of weave affect fabric texture, durability, and stability. The denser the weave and the more interlacing points there are, the more durable the fabric will be. The simpler and balanced the weave, the more durable it is. The longer a thread is exposed, or floating, the more it is susceptible to wear, snagging, and seam slippage. The direction of the abrasion or friction determines how the fabric will wear. For instance, floats of a weave that are perpendicular to the seating direction experience significantly more snagging.

Plain weave has a basic over-under pattern, very strong and durable, featuring a subtle texture particularly suitable for printing applications. Basket weave is a variation of the plain weave with an over-over-under-under pattern and

slightly less strength due to reduced interlacement of threads. **Twill weave** is characterized by a diagonal construction rendering it more durable to unidirectional wear. The widely recognizable texture of denim is cotton twill weave. Herringbone weave is a variation that alters the direction of twill lines, creating a distinctive zig-zag pattern. **Satin weave** features extended floats for enhanced luster, however, it is prone to abrasion and snagging. Most other weave types are variations of these basic weaves.

Computer-driven looms that are highly capable in articulating yarns allow for highly complex and visually interesting weaves. **The jacquard loom** was the precursor of the modern computerized looms, it utilized punch cards to automate the complex weaving process. Today, the term Jacquard is also used to refer to all automated power looms that can create complex weaves such as brocade, damask, brocatelle, messier, pique, and tapestry. Moreover, it is not uncommon that all of these different complex weaves are referred to as simply Jacquard weaves.

In weaving, two straight threads run perpendicular to each other, whereas in **knitting**, a single thread meanders, both creating and going through consecutive connected loops. As a result, the knitted fabric gains high elasticity, bulk, and provides great insulation, especially

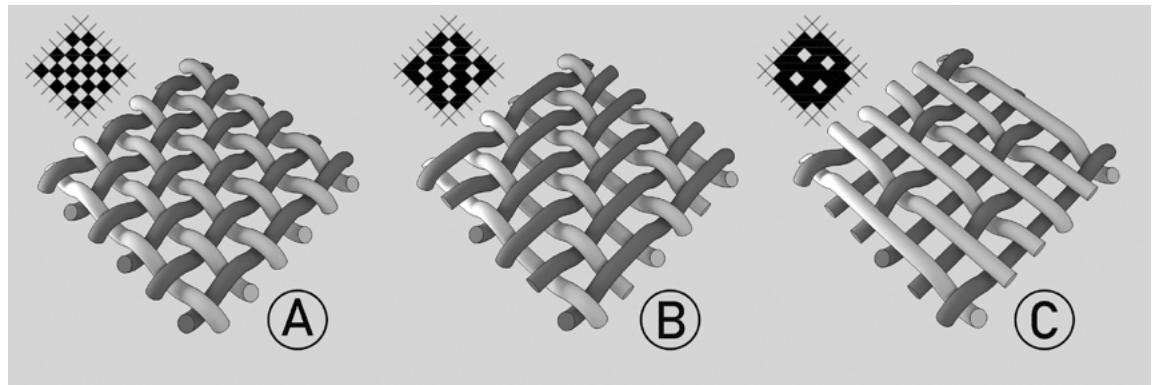

Fig.09/12 Common weave types include plain weave (A), twill weave (B), and satin weave (C).



Fig.09/13 An original Jacquard loom with punch cards, that detail the pattern, fed from the left.

desirable for winter apparel. Knitted fabrics are harder to work with and sew, they are prone to snagging and pilling.

Felting refers to compressing or matting randomly arranged fibers, often in a solution. Felting is fairly straightforward and has a history stretching 8000 years back to Asian nomadic tribes. Felted fabrics are usually compressed or needled wool or wool blends, categorized as non-woven. Felt is a great insulator, can be



vid.09/04 Video on the comparison of weaving and knitting.

very firm and strong, or soft and easily workable depending on the manufacturing process. The acoustical advantages made felt slats, tiles, and panels a popular way to introduce color and texture to an interior space while controlling the acoustics of the interior environment.

Fibers, yarns, or whole fabrics can be dyed or printed on. *Dyeing is a **water-intensive** process.* Over 20% of the discharged water from dyeing processes contains pollutants. **Mercerizing** involves treating fibers in a caustic solution (sodium hydroxide) and stretching them. This process enhances the luster, absorbency, and dye affinity while reducing shrinkage.

There are multiple dyeing methods, each with different purposes, features, and price points. **Solution dyeing** refers to coloring the melted synthetic resin before it is drawn into fiber; different than other methods where color is applied to the fiber, yarn, or woven good. Since the color is inherent to the material, this technique provides higher colorfastness, lightfastness, and stain resistance as the pigments are part of the composition of the fiber. Custom coloring is relatively hard with long lead times. **Stock and Skein dyeing** involves submerging stocks of fibers or yarn skeins – which are loosely coiled yarns – into boiling dye vats, allowing the pigments to penetrate the material. This is a fairly old,



Fig.09/14 Traditional skein dyeing involves submerging the yarns in boiling dye vats.

labor-intensive, and expensive method, though colorfastness is fairly high. The fiber or yarn also gains a softer fuller feel. The dyeing process is fairly quick, measured in hours, and custom colors can be done fairly quickly. **Greige goods** are undyed, colorless (gray) textile products that are waiting to be further processed. **Piece dyeing** involves dyeing woven or knitted fabric or carpet in large batches. Very useful for large solid color fabrics. Relatively cheap and large amounts of material can be dyed very quickly, however, visual evenness and color retaining ability are relatively low. Crafted pieces can also be piece dyed. **Printing** is a way to attain complex patterns without the cost of a complex weaving process. There are two major printing methods: screen printing and digital printing. Screen printing involves creating several large screens to transfer transparent colors in overlapping layers, when combined forming an image or a pattern. This option is cheaper when large production volumes are involved. On the other hand, in digital printing, the printing area and output volume are limited, though the result can be higher quality with techniques such as dye-sublimation. It is priced per product, hence expensive regardless of volume. For both printing methods, the durability and color retention properties would be fairly low as the color is not inherent to the fiber but it is merely a topcoat.

Colorway is a term used to refer to textile color schemes, often containing two or more colors. Alternative colorways may be present for each pattern. This term applies beyond textiles, to many other designed products. Color trends in the textile industry rapidly change. Consequently, the designer should be mindful of the

via.09/05 Video on traditional dyeing with natural pigments.



Fig.09/15 Textile patterns often feature various colorway alternatives.

fact that many patterns or colors can go out of fashion and become hard to procure.

Textile finishing is the final process that the product will go through, in order to improve the performance and appearance of the fabric, such as shrinkage and wrinkle control, UV protection, moisture resistance, impermeability, fade resistance, stain resistance, insect, mold, and bacterial control, etc. **Flame retardant finishes** can help reduce or prevent combustion. However, direct skin exposure, especially of younger children, to these finishes should be minimized due to potential health risks. Such treatments can also be corrosive, therefore any metal component in contact should be carefully selected. **Glazing** is a process that introduces sheen and smoothness to a fabric surface. The fabric is first impregnated with the desired wax or resin, then, a calendaring process – which is compressing fabric in between two heated rollers – is used to apply polish via friction. This process increases the durability of the fabric, very useful in upholstery applications. One example of this process



Fig.09/16 Nanocoating imbue fabrics with desirable qualities, yet they tend to wear off with use.

is the fabric type known as “chintz”, which is fundamentally shiny glazed cotton, featuring floral patterns. **Nanocoatings** can be applied to enhance fabric properties such as cleanability, abrasion-resistance, and hydrophobicity. Nanocoatings, as well as other finish coatings wear off over time.

Fabric weight is the measurement of the weight for a unit area, typically expressed in ounces per square yard; it is a good indicator of the workability and durability of a textile. Lightweight fabrics have a weight of less than 4 ounces (per square yard) and are appropriate for upholstery, draperies, linings, etc. Medium-weight fabrics have a weight of 4 to 10 ounces and are appropriate for upholstery, draperies, decorative elements, etc. Heavyweight fabrics are over 10 ounces and are appropriate for upholstery, draperies, etc. Similar to fiber weight, fabric weight does not immediately determine quality.

When specifying fabric for various uses, the designer needs to consider a multitude of variables in order to judge the suitability, cost, and

life expectancy of the product. Each one of the prominent variables is elaborated on below.

Abrasion Resistance signifies the capacity of the fabric surface to resist mechanical wear via friction with another surface, a good indicator for the useful life of the fabric. There are two important abrasion tests that designers frequently encounter when specifying fabric: Wyzenbeek and Martindale abrasion tests. **The Wyzenbeek method** features a sandpaper abrader being rubbed against the fabric test sample and the number of double rub cycles before yarn breakage indicates abrasion resistance of the fabric. On the other hand, **the Martindale method** involves a wool abrader moving in a figure 8 pattern, instead of sandpaper moving back and forth, and the outcome is measured in cycles. Consequently, more cycles of the Martindale test can match the performance in the Wyzenbeek test. For example, textiles with 10K double rubs in Wyzenbeek test and 15K cycles for Martindale test performance are appropriate for residential use, and 30K double rubs in Wyzenbeek test and 40K cycles for Martindale test performance are appropriate for commercial use. When going through fabric test results it is not uncommon to see products with 100K to 250K published results. Another important abrasion test is the **Taber test**. This method is commonly used for leather but for other textile and non-textile products as well, including but not limited to vinyl sheets, powder-coated metal, or hardwood. This test features a revolving sample under two revolving abraders with change-able weights. So, Taber test results can vary based on different weights and abrader types and when comparing products this needs to be considered.

Vid.09/06 Video showcasing the Wyzenbeek abrasion test.



Pilling is caused by short filaments breaking away from the yarn due to abrasion and forming small chunks of lint on the fabric surface. Staple length and yarn construction directly determine the intensity of pilling. Wool, cotton, and polyester fabrics pill more; and linen, silk, and nylon pill the least. Every fabric eventually pills, therefore pilling is not considered a defect and does not correlate with fabric quality. The designer should anticipate the amount of abrasion the textile will receive and specify a fabric with tighter yarns and longer staple lengths to minimize pilling. **Fraying** refers to the threads at the edges of a woven fabric coming loose. This affects seam allowance and might hasten seam slippage under heavy traffic load. Heavier fabrics with tighter weaves fray less than lighter fabrics with looser weaves. **Selvage** is a densely woven edge of the fabric to prevent fraying in textile while stored, it is not intended to be used as part of textile construction. Nonwoven and knitted fabrics

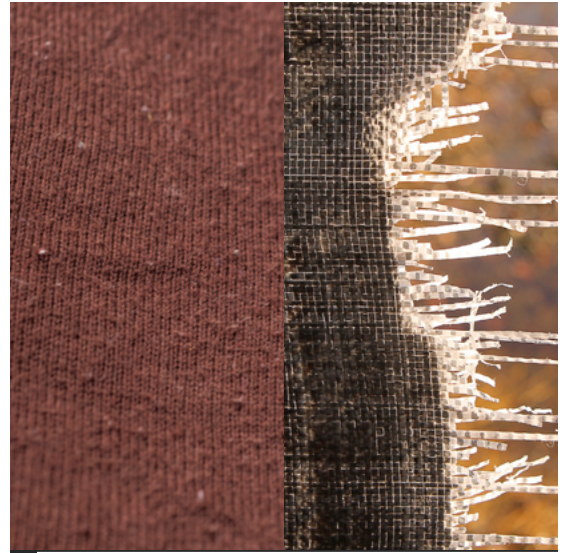

Fig.09/18 Examples of common textile wear: pilling on the left and fraying on the right.

CONTENT 83% Wool, 15% Post-Cons. Recycled Polyester, 2% Acrylic	ABRASION RESISTANCE Martindale Test - 65,000 Wyzenbeek Test - 50,000
WIDTH / WEIGHT 57 in. / 14.7 oz.	FLAME RESISTANCE NFPA 260 - Class 1 CAL 117 / 2013 Section I - Pass
COLORWAYS Ash, Fire Opal, Green Tea	COLORFASTNESS TO CROCKING AATCC Method 8 Wet: Class 3 / Dry: Class 4
PATTERN REPEAT H: 2.3, V: 2.4	COLORFASTNESS TO LIGHT AATCC Method 16 (40 Hours) Class 4
AVERAGE BOLT LENGTH 55 yd.	CLEAN AIR CERTIFICATE Gold
CUTTING DIRECTION Non-Railroaded	PILLING RESISTANCE ASTM D3511 - Class 4
CLEANING Only use mild, pure water-free dry cleaning solvents.	SEAM SLIPPAGE ASTM D434 / D3597 Warp: 53 lbs, Fill: 71 lbs
SEWING Ball-tipped needle and polyester thread are recommended.	BREAKING STRENGTH ASTM 5034 Warp: 282 lbs, Fill: 295 lbs

Fig.09/17 Sample textile information card.

won't fray. **Seam Slippage** refers to a section of seam pulling apart and opening up due to fabric construction giving in, yarns opening up, and stitches losing grip. When constructing a seam, the number of stitches per inch can be increased especially in areas expected to receive higher pressure, such as seat cushions and armrests. A fabric with a denser weave construction can also be used, the fabric can be reinforced at the seam, hemming or overlocking can be applied. **Overlocking**, also known as a serged seam, is a seam constructed with multiple threads, the edges are cut off and automatically finished so fraying is minimized.

Colorfastness refers to the ability of a textile to hold onto pigments and resist color loss. Some textiles can lose color and fade significantly based on abrasion, UV exposure, water and moisture exposure, heat exposure, and reaction to cleaning products and other chemicals. The dyeing method, type of dye, dye penetration, hue and shade, all determine the strength of colorfastness. **Crocking** is the smearing of textile dye

to another surface and causing staining through contact. There is a wet and a dry crocking test available for measuring crocking resistance with grades assigned based on the fabric's performance. Grade 5 signifies no transfer and Grade 1 is high degree of color transfer. For upholstery and drapery Grade 3 and up is required. Sometimes crocking resistance information is provided as colorfastness, or colorfastness to crocking. The test methods are developed by the American Association of Textile Chemists and Colorists (AATCC). **Lightfastness** is the resistance of the textile against fading under UV exposure. Similar to crocking resistance test, AATCC developed another test for lightfastness which exposes the fabric sample to a carbon-arc or xenon-arc lamp for 40 hours of accelerated fading units (AFU) and compares fading. 1 hour of AFU approximates to 1.3 hours of direct sunlight exposure. Similar to crocking resistance, Grade 5 signifies no fading, grade 4 is slight fading, and grade 1 signifies little fading resistance.

All textiles soil and stain during use, and based on the extent of active usage, **periodical cleaning** is necessary. Not all fiber types and fabric constructions are compatible with every cleaning product and method in the market. The cleaning procedures for healthcare or restaurant environments are different from an executive office or a residential environment. The cleaning protocols and practices to be employed need to be checked with the manufacturer's cleaning recommendations for the product. **Commercial grade** textiles can withstand the harsher types of cleaners, whereas **residential grade** textiles are relatively more delicate.

Yarn weight and bulk are only one facet of wear resistance; spinning method, weaving method, density, and overall build quality, all factor in to **wear resistance** of a fabric.

LEATHER

Leather is a non-woven sheet product, classified as textile, manufactured from hides of animals such as cattle, sheep, goats, pigs, reptiles, and even birds. Leather is speculated to be the first utilized textile in history, possibly worn as clothing while also being used for shelter construction and insulation. Leather boasts strength, puncture and tear resistance, insulation, breathability, elasticity, and moldability. It also exhibits resistance to chemicals, abrasion, fire, fungi, and mildew. Leather is very versatile; it can be dyed, painted, embossed, carved, or stamped. The majority of hides obtained for leather production are by-products of the meat industry, implying that it is a rapidly renewable and sustainable material at first glance. However, **leather tanning processes require substantial amounts of water and chemicals to produce workable and durable leather, resulting in nega-**



Fig.09/19 The historic leather tanning pools in Fez, Morocco are the oldest in the world.

tive environmental impact. Leather is a recyclable material; even though the resulting product, known as bonded leather, is of inferior quality. Besides the environmental impact, public sensitivities are a concern as well; various groups of people are known to be against leather use due to religious or humanitarian reasons.

Left untreated, leather is extremely perishable, quickly deteriorates, and decomposes therefore it is immediately cured. After being transported to the processing facility, hairs are chemically removed with the liming process. At this stage, the excess flesh is also removed and the hide is split into desired layers. This process is followed by tanning, dyeing, and finishing. *The raw hide itself is thick and is commonly **split into multiple layers** with distinct properties. **Rawhide** refers to the de-haired and cured but untanned leather. Typically rigid, becomes workable when wet. It acquires a natural patina with use. **Full-grain** is the outermost layer of a hide. The entire grain is unaltered, featuring natural scars and blemishes. It is highly desirable and expensive due to resilience and visual character. **Top grain** is positioned slightly below full grain, second in terms of quality. Its surface is corrected via sanding and buffing to create a consistent and smooth result and embossed with an artificial grain pattern, lacking natural variations. **Split grain** is the lower and thinner layer of leather with loose collagen fibers. This layer can also be embossed with artificial grain or buffed to create suede. **Genuine** leather produced from this layer is actually of lower quality and desirability. **Bonded leather** is the lowest grade leather: featuring shredded leather scraps reconstituted with bonding agents pressed into sheets. It is highly susceptible to cracking, peeling, and flaking. A fabric backing can be covered with a polyurethane (PU) or vinyl (PVC) layer then embossed with leather grain texture to manufacture **artificial leather**. Vinyl's natural sheen creates a plasticky look therefore forming a fake and cheap impression. Polyurethane, with its*

vid.09/07 Video on the types of leather.



more diffuse visual quality, higher breathability, strength, and durability, is considered a good alternative to natural leather, though it is considerably more expensive than vinyl. The polyester and polyurethane blend **Alcantara** can mimic suede with enhanced qualities, providing durability and stain resistance.

Tanning is a chemical process that inhibits decomposition of the hide by binding chemicals to collagen fibers, permanently altering the protein structure. There are two fundamental ways of tanning: one is chromium tanning and the other is vegetable tanning, named based on the chemicals used in the process. Almost 90% of all leather receives **chromium, or mineral, tanning** treatment. The resulting leather attains high flexibility, it is more workable, and can be dyed in a large variety of colors. The trivalent



Fig.09/20 Artificial leather is highly susceptible to cracking and peeling.

vid.09/08 Video on the steps of the tanning process.



chromium (III) used in the process is not as toxic as chromium (VI), but it is still considered environmentally problematic. **Vegetable tanning** is a lengthier and more expensive tanning process, during which the tannins in tree bark, especially from oak, are utilized. The resulting leather becomes relatively stiffer after drying, however, it is comparatively more durable. The color choice is limited to shades of brown. It features a unique smell and develops a dark patina over time if the natural grain is exposed.

Leather is graded based on the quality of the hide and presence of damage and defects, such as holes, cuts, wrinkles, scores, and gouges as well as visible grain defects. The various areas of the hide such as the neck, belly, and bend – which is the central area – yield different quality hide. A high-quality grade A/No1 hide contains



Fig.09/21 Leather defects determine the quality grade of the material.



Fig.09/22 The required leather pieces are outlined in a way to keep desired patterns and leave out defects, while using the hide as efficiently as possible.

almost no defects, grade B/No2 hide contains individual defects no larger than 1” and less than 1sqft of warts, and for grade C/No3 hide criteria is more than 50% of the surface area should be usable. The lowest grade is called utility grade. The following will affect the cost of the leather: ① species of the source animal; ② origin and health of the animal; ③ quality of the rawhide; ④ method of manufacturing; ⑤ tannery practices (regulations and quality standards); ⑥ dyeing and finishing process.

Leather can have a large variety of finishes. It can be dyed, waxed, oil-treated, embossed, perforated, brushed, sanded, buffed, or distressed. **Aniline dye**, comparable to wood stains, is a penetrating translucent dye that imbues the leather with brightness while enhancing the natural grain pattern, color variations, and imperfections. Highly desirable and expensive, yet aniline leather requires careful maintenance and regular conditioning. In **Semi-aniline dyeing**, the leather features a protective topcoat while featuring a slightly more uniform



Fig.09/23 Chromium tanned and artificially dyed leather can feature any color.

look. **Artificial dyeing** is the application of a protective solution with opaque pigments as a topcoat on buffed and sanded leather. The natural texture and color is removed and the material is embossed with an artificial grain pattern. A large range of colors can be attained with absolute control over texture consistency, and the resulting product is more durable.

Leather has various interior finish applications besides upholstery. **Leather tiles** are often manufactured from unsplit full hides, commercially available for vertical surfaces as well as for flooring applications. It provides a robust and refined appearance, might be associated with luxury and prestige. However, these tiles are susceptible to staining, deteriorate under UV exposure, and not suitable for medium to high traffic loads, moreover, they require yearly conditioning and maintenance. In any case, it is important to use a **leather conditioner** to sustain the material's health and suppleness. Leather requires gentle cleaning practices, such as being wiped with a damp cloth.

Vid.09/09 Video on leather conditioning.



CARPET

Carpet is a versatile and relatively low-cost woven floor covering. **Carpet** has a litany of variations based on yarn properties, weave, and composition. It caters to a large variety of spatial design scenarios. Carpet weaving is an ancient art, origins tracing back to the Neolithic period. Started out as a handmade and fairly expensive product, carpet gradually became affordable and varied since the introduction of the first woven carpet mills in the 18th century. A major milestone was the introduction of the mechanized tufting machine in the early 20th century, which streamlined manufacturing and significantly reduced costs. As of 2022, carpets accounted for a **33.7% market share** in the US floor covering industry.

Carpets feature the same types of fibers that are used in many other fabrics, such as wool, nylon, acrylic, olefin, etc. Although, the yarn construction is thicker and it features techniques such as bulking and crimping to increase wear resistance. When choosing the appropriate fiber, the designer should focus on abrasion, flame, and fade resistance values as well as the price point. *Due to its versatility and performance characteristics nylon seems to be the most popular fiber for carpet manufacturing today with almost 30% of the market share.* **Bulked Continuous Filament (BCF)**, is single continuous nylon, or other synthetic, fiber that is given bulk through a zig-zag or randomized crimping process. Since there's no yarn spinning involving shorter staple fibers, the resulting yarn is more durable, wear-resistant, and won't shed and lint like many natural fibers, such as wool which is only available as staple fibers.

Aside from the properties of fibers being used, carpet construction is important in determining the purpose and quality of the product. High-quality carpets typically feature densely packed yarns. **Woven carpets** offer more durability and stability for an additional cost, preferred for high



Fig.09/24 Carpet is one of the most popular flooring materials throughout the US.

traffic loads and demanding locations, where the aesthetic value is also important, such as casino lobbies and corridors. There are two important types of carpet weaving: Axminster and Wilton. **Axminster** weave can feature up to 10 colors and intricate patterns often specified for hospitality and healthcare environments where visual versatility and a sense of luxury are as important as durability and strength. **Wilton** weave features a continuously running yarn, therefore, there are fewer colors, smaller pattern size, and pattern complexity is limited. Due to its more complex interlaced construction, it has relatively higher durability, dimensional stability, and body. Both weaves are suitable for bespoke designs. As opposed to woven carpet construction, in **tufted carpets**, yarns are inserted through the backing and then secured into place. Tufted carpets are significantly cheaper, simpler, and faster to manufacture than any woven alternative. Tufted carpet construction is one important reason why carpeting became so prevalent in the US. In **fusion-bonded carpets**, yarns are set



Fig.09/25 Woven carpets are commonly specified for high-end high traffic spaces, such as casino atriums.

at specific lengths and densities, then affixed to a polymer backing using a liquid adhesive, ensuring they are firmly anchored. This is an even cheaper construction as there's no need for stitching.

*Tufted carpets allow for relatively limited visual variety and they are said to have lower durability, though this is also largely determined by the **manufacturing quality** of the specified product.*

The way piles of yarn are finished is another important property for carpets. **Cut piles** are manufactured by shaving the ends of the yarn loops. Exposed ends render this pile type dense, plush, and pleasant yet less durable. Cut pile is highly susceptible to showing footprints and crushing. Oppositely, **loop piles** are manufactured by leaving the loops of yarn untouched. They are suitable for high-traffic as the yarn ends are not exposed. It is possible to combine cut and loop piles on the same carpet to create

vid.09/10 Video on the differences of nylon and wool carpet fibers.



vid.09/11 Video on the differences of tufted and woven carpets.



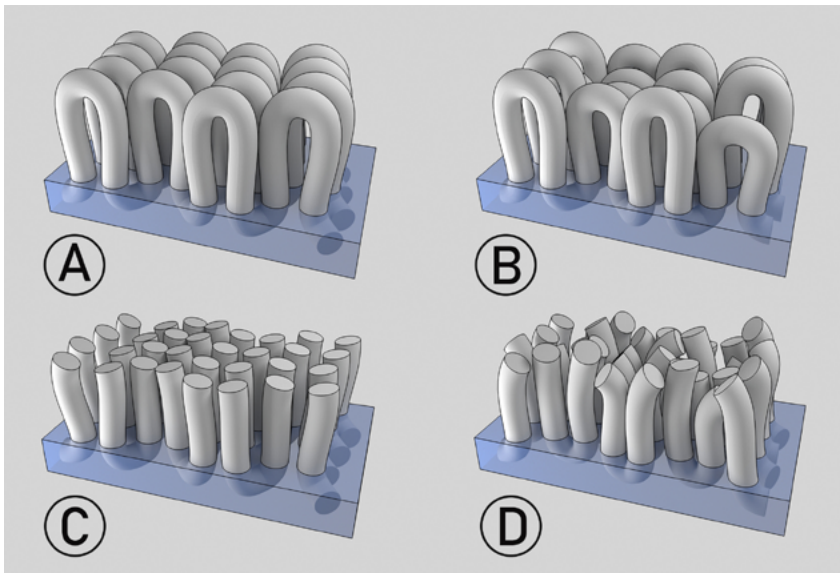

Fig.09/26 Common tufted pile types include level loop (A), multi-level loop (B), cut loop (C), and twist pile (D).

visual interest. In a **twist pile**, each yarn is tightly twisted. When cut, the twist opens giving body to the yarn, provides durability, hides footprints and vacuum tracks. The fuzzy appearance of twist pile is useful in hiding stains. The designer should consider that the complexity of visual patterns help conceal soiling and track marks.

There are various important structural properties that apply to all carpet constructions, determining their performance under use. **Stitch rate**, or stitches per inch, denotes the number of fibers per inch. This value ranges from 5 to 12 per inch, or 25 to 144 stitches per square inch. A higher number indicates higher durability. **Gauge** refers to the distance between each stitch, 8 stitches per inch would equal to 1/8 gauge. For woven carpets a different unit, **pitch** is used, which is the number of ends or stitches per inch multiplied by 27". So 8 stitches per inch would be equal to 216 pitch. **Pile density** refers to the density of fibers on a carpet surface, based on the number and size of tufts per unit

area. Expressed in ounces per cubic yard. For example, commercial carpets range from 4200 to 8000.

Low-density carpets cannot resist crushing, quickly reveal seams, and fail to retain appearance, therefore not appropriate to receive heavy traffic.

Even though longer **pile height** is more comfortable and pleasant underneath the feet, shorter pile height is more durable, cleanable as it can resist staining, matting, and crushing, which is especially important for nylon fibers. Short pile height is more appropriate for commercial applications where appearance retention under heavy traffic is key. The designer should also consider that longer pile height means retaining more dust, dirt, and mites. Without frequent and correct cleaning, this might affect indoor air quality negatively. It is possible to have varying pile heights for creating texture. **Shag carpet piles** that are substantially deeper, creating a fluffy appearance. Despite being comfortable with a softer feel, it tends to trap dust, debris, and mites, while being challenging to clean. **Face weight** refers to the total weight of carpet yarn per square yard. This value ranges between 20 to 100 ounces, however, a higher number does not always correlate with durability. Face weight is helpful for comparing carpets with the same



Fig.09/27 Pile height can be manipulated for texture effect.



Fig.09/28 The pile depth of shag carpet provides comfort, however, it is also difficult to clean.



Fig.09/29 Carpet pads improve both physical and acoustical performance of the carpet.

construction. Only then it can accurately indicate higher strength, otherwise, it can be misleading. Total weight value includes face weight as well as the weight of the backing.

Carpet backing is the foundational sheet layer underside of the carpet, providing dimensional stability and durability. There can be two layers of backing: one securing the yarn loops in place and the other one supplying support, strength, weight, and in some cases, padding. Depending on the quality of the construction, the secondary backing can delaminate over time, creating ripples and wrinkling on the surface.

Carpet pad is an underlayment typically placed during carpet installation; while increasing comfort it adds resilience, insulation, acoustical absorption, and extends the lifespan of the carpet. The carpet pad also enables the carpet to be installed on any even substrate, softening any irregularities. As a result, the visual integrity of the upper layer does not suffer. There are many padding alternatives on the market such as polyurethane (PU) foam which can be thicker and squishier, or rubber which can be thinner and denser. There are also synthetic fiber pads that feature a felt-like appearance and consistency, or re-bonded foam scrap which is manufactured from all recycled content, therefore, more envi-

ronmentally friendly. A thicker and softer carpet pad is useful for achieving comfort while sacrificing durability and appearance retention. On the other hand, a firmer thinner carpet pad achieves more durability under high traffic load though comfort and sound absorption/insulation are sacrificed.

Color can be applied on carpets in a multitude of ways, similar to other textiles. Fibers or yarns may be dyed before fabrication or the coloring might happen after the weaving process. **Pre-dyed carpet** refers to a dyeing the fibers before they are tufted or woven into the final carpet. This way, color is infused to the fiber; achieving higher colorfastness. **Postdyed carpet** refers to a dyeing process after the carpet is fabricated. It is possible to piece dye or print on a carpet. Postdyed carpet will have low colorfastness, and as it wears away it will develop an undesirable faded look.

Carpet size is a crucial concern for the designer. The most common size is the **broadloom carpet**, typically at 12' wide, though there are wider or narrower alternatives available depending on the manufacturer. **Carpet tiles** are modular square pieces with dimensions of 18" by 18" or 24" by 24". These are more convenient to install and remove, they can also be arranged



Fig.09/30 Carpet tiles are especially useful when access to the substrate is required.

in custom patterns. Carpet tiles are suitable for replacement, especially for high traffic sections that can crush and wear under heavy weight. It is also convenient for accessing the substrate. How carpet tiles are laid out is important. It is useful to create a diagram to balance the look and minimize thin pieces and slivers. Upon entering a room the occupant sees the center and the opposite edge of the flooring. Therefore, *it is imperative to align the most visible pieces to the center and the opposing walls to achieve a balanced, pleasant look.*

Essentially, **rugs** are pieces of carpeting that are unfixed, floating on the substrate or finished flooring. They can be of any size, though they are typically smaller than the room that they occupy. Rugs can be hand- or machine-made to specific or custom dimensions or they can be cut from broadloom carpets. Rugs feature a finished border to minimize fraying due to exposed edge fibers. Rugs serve various functions aside from providing warmth and comfort, such as defining an area, delineating paths, directing attention,



Fig.09/31 Persian rug being hand-crafted.

and visually relating spatial components; or they can protect the substrate and provide slip resistance.

The **Carpet and Rug Institute (CRI)** is an independent non-profit organization that sets standards and develops tests for carpet installation, cleaning, maintenance, removal, and end-of-life procedures. **CRI Green Label Plus** program is important in identifying carpets, paddings, and adhesives with low VOC emissions. The National Sanitation Foundation (NSF) also develops standards for carpeting. For instance, the NSF/ANSI 140 Sustainable Carpet Assessment Standard takes a broader, life-cycle assessment based approach awarding public health and environmental considerations, bio/based recycled content, reclamation, end-of-life management, as well as overall manufacturing and innovation.

*Carpet is a complex material featuring multiple components enmeshed together and it is **very hard to recycle**.* Face material has to be identified and separated from the backing. The resulting yarns are often too short and hard to process

due to the coloring, additives, and finishes applied during manufacturing. On the other hand, the unrecycled carpet directly contributes to landfills. In order to counter this, the State of California has established the “Carpet Stewardship Program” to incentivize and increase the recycling ratio of carpet, establish drop-off sites and collection procedures, as well as develop educational programs. Carpet America Recovery Effort (CARE), is a nationwide non-profit program that serves a similar purpose.



vid.09/12 Video on the intricacies of recycling carpet.

CARPET INSTALLATION

There are two common types of carpet installation: stretch-in installation and glue-down installation. In **stretch-in installation**, tack strips are secured to the subfloor along the perimeter of the application area, and following the seaming process, the carpet is tightly stretched across with knee kickers or power stretchers. This method is not suitable for larger areas as the installation process would be very difficult and the carpet can loosen, buckle, and ripple. Also, under heavy circulation load, the seams would quickly peak. Nonetheless, for smaller residential spaces, this is a fairly straightforward, quick, and convenient application where no adhesive is involved, therefore VOC emissions will be very limited. This is especially useful if moisture and heat release is expected from the substrate. A carpet pad or cushion can be placed underneath the carpet, significantly increasing comfort. The lack of adhesives also allows for relatively easy removal and replacement of worn carpet and padding.

The other major method is the **glue-down installation** which typically involves gluing the



Fig.09/32 The long tool is the power stretcher, a crucial tool for stretch-in installation process.

carpet to the substrate. This method is suitable for commercial and public interiors as there are no installation area restrictions, the flooring has higher dimensional stability and reduced movement under high traffic loads, including rolling loads, preventing the carpet from buckling or rippling. It is especially suited for stairs and ramps. The direct glue-down installation does not typically feature a carpet pad or other cush-



vid.09/13 Video on stretch-in carpet installation.



Fig.09/33 Glue-down application involves a thin layer of adhesive on a smooth substrate.

ioning, offering limited comfort and insulation. This means there's no cushion cost, however, there are other labor requirements. For instance, the substrate needs to be perfectly flat, as without any padding in between, the imperfections would telegraph through very easily. Furthermore, irregularities can cause undesirable wear patterns. The **double glue-down installation** features a pad that is adhered to the floor, and the carpet is adhered to the pad. This is a stable, durable, insulative, and comfortable installation, however, it is time-consuming and relatively expensive. One big downside of glue-down installation is stripping the worn carpet, which is more difficult compared to the stretch-in method. When constant flooring replacement is expected, carpet tiles might be a better option compared to a broadloom carpet. *Glue-down installation also enables the designer to utilize custom CNC cut inlays and graphic inserts* which are not possible with a stretch-in installation. Aside from the substantial expertise requirement, this technique is time consuming and expensive. Another

important concern with glue-down carpet installation is the VOC emissions during and following the application. The designer should be careful when specifying the adhesive, paying attention to specifying low VOC alternatives.

*Curing time for carpet adhesives is another important concern. Adhesives can have **varying curing times** and accordingly, the application area should be closed to traffic until the adhesive is fully cured.*

There are **self-stick, or peel and stick** alternatives in the market sold in carpet tile format. These are suitable for small-scale and quick DIY projects, and temporary corrections. They are very cheap to install, however, the seams between tiles easily open up, and since there's no padding, wear can be very inconsistent. *It is also possible to loosely lay a cut-to-fit carpet in an area, without stretching or gluing. This method is referred to as **free lay**.* This is a very simple installation method, enabling the easy removal of the carpet. It is very well suited in situations where constant aeration or cleaning is needed. However, the carpet will constantly shift and move, and in some cases it might slip if the backing is not rigid enough or there's not enough friction between the backing and the substrate, causing significant safety issues.

With the exception of carpet tile installation, both the stretch-in and the glue-down methods require **seaming**, either by hot-melt taping or sewing. A seam diagram shows the exact location of seams and nap directions. **Nap** is the prominent direction of fiber ends on the carpet. Even though preparing a seam diagram can be somewhat time-consuming and expensive, it is useful for assessing the aesthetics and expected wear of the carpet application and possibly minimize wastage. **Nap direction** often runs the length of the carpet. When the nap direction is not aligned well between seams, the seam can

vid.09/14 Video on glue-down carpet installation.





Fig.09/34 A grooming roller can be used to improve the performance and look of the seam.



Fig.09/35 Trim strips conceal the seam between two different flooring materials.

become visible. But more importantly, if the nap direction opposes the prevailing traffic direction, the wear will be more intense in addition to the detriment to walking comfort. Even when the nap direction is aligned properly, seams can still become visible after a period of use, therefore, aligning the seams in a way to minimize visual exposure and receive less traffic is important for retaining the look in the long term.

Trim strips are used to cover the transition between two different flooring applications to prevent edge deterioration and to ensure a clean finish. Any exposed carpet edge is more susceptible to wear, and in the case of a carpet, trim strips minimize fraying of the exposed edges. **Carpet shims** are used to raise the carpet application, for smoothly transitioning to a thicker or higher floor finish, especially when it is not practical to adjust the substrate height.

Due to a large number of gaps and crevices between each pile and tuft, combined with the electrostatic build-up, carpets not only attract dirt but also hold onto it. This creates a constant need for cleaning. Moreover, besides being a detriment to indoor air quality, dirt and grit abrade the fibers creating a faded look, especially for synthetic fibers. Aside from regular vacuuming, periodic deep cleaning can be done to attain a relatively clean carpet.

The designer should consider that the deeper the carpet pile, the **more dirt or spills will be pushed into the pile** and cleaning will become increasingly harder.

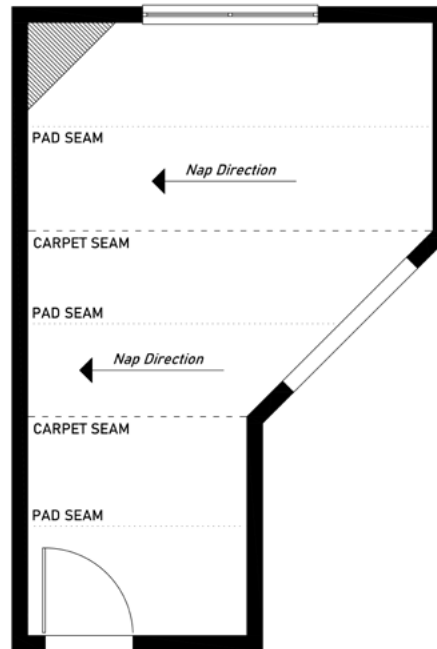

Fig.09/36 Sample carpet and pad seaming diagram with nap direction.

UPHOLSTERY

Upholstery refers to a common method of textile-based fabrication that is based on framing, padding, and sewing to create and retain form. Upholstered furniture typically feature a frame, webbing or spring suspension, cushioning, and fabric. Custom upholstered furniture should feature a wood frame construction, preferably kiln-dried to minimize dimensional movement. Plywood and MDF can also be utilized. The construction typically features dowels, glue, screws, brackets, and staples in combination. Edges of the framework should be rounded to avoid upholstery wear. The frame can be reinforced by utilizing corner blocks or brackets.

The designer should pay close attention to the weight and density of the foam being specified.

Polyurethane (PU) upholstery foam is the most common cushioning material. The durability and support is dependent on the foam's density. The indentation load deflection (ILD) is a test outlined by the Polyurethane Foam Manufacturer's Association, measuring the firmness of PU foams. An ILD value of 8 is very soft, whereas 50 would

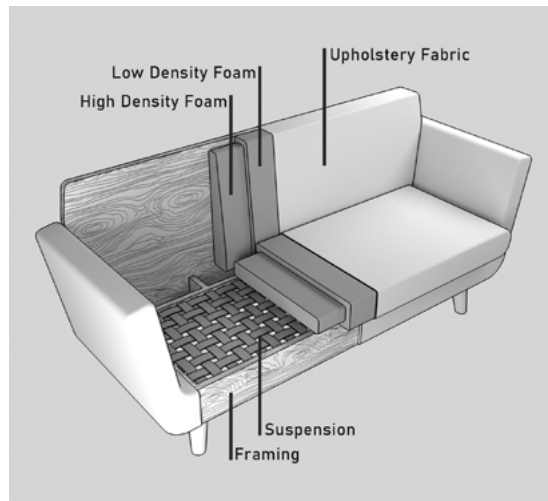

Fig.09/37 The individual constituents of a typical furniture piece.



Vid.09/15 Video on timber furniture frame construction.

be very firm. A typical application would feature multiple layers of foam at different densities to achieve desired firmness. These can be CNC cut to support different parts of the body as it shifts on the seat, sofa, or bed. For instance, a semi-firm thin outer layer, softer middle layer, and a firmer inner layer can achieve a great sense of comfort and support while minimizing fabric wear. The foam may be surrounded by polyester fiber batting, such as Dacron, to prevent slippage and retain appearance. Back cushions can be filled with polyester fiberfill, down, or shredded polyurethane foam. The general feel of an upholstery is determined by the padding and fabric together. Consequently, a softer foam underneath a firm and heavy fabric won't feel as comfortable. **Suspension systems** can also contribute to the overall comfort when used in conjunction with foam. They flex in reaction to

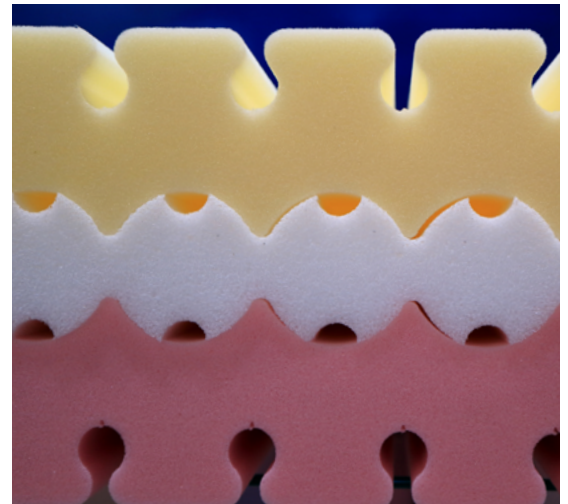

Fig.09/38 Many layers of different density foam should be used to provide proper support.

body weight and movement, increase support and comfort. A typical suspension system would feature springs, coils, straps, webbing, and meshes, often in combination.

*Upholstery, as it relates to unfixed mass-manufactured furniture, is not part of the construction contract but rather part of the **furniture, fixture & equipment (FF&E)** contract.* Therefore, custom upholstery acquisition and coordination is often the responsibility of the FF&E contractor, which can be a furniture dealer or the designer themselves. This is one of the reasons why big furniture manufacturers such as Knoll and Herman Miller also sell proprietary upholstery fabric.

Fabric pattern matching is an important consideration as it relates to upholstery. Proper alignment is crucial for a clean, professional and pleasing look. Complex patterns can be difficult to match and result in a lot of wastage to achieve a satisfactory alignment. The process requires substantial skill on the craftsperson's part, however today, digitalized visualization, matching, cutting, contouring, and stitching systems help with the process and minimize wastage.

There are two ways to apply patterns on a piece of furniture. *In the more traditional **regular (run-right) application** the patterns run on the vertical axis, perpendicular to the floor.*

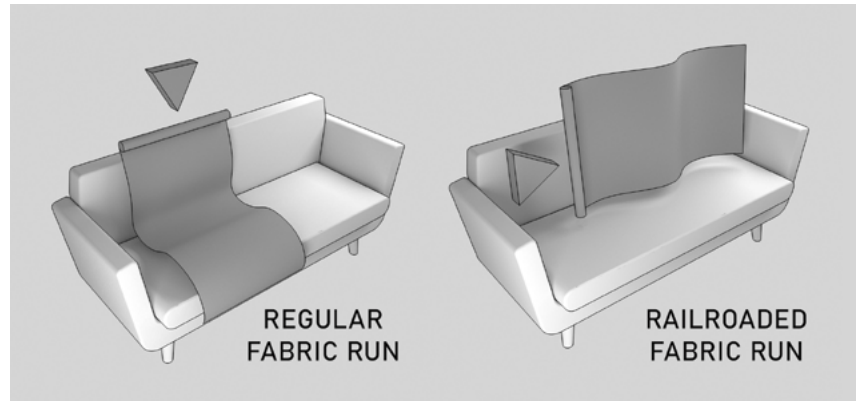

Fig.09/40 Common pattern alignment methods for upholstery.

At around every 44" to 54", a seam is needed due to limitations in fabric width, depending on how much is left after seam allowance. *In **rail-roaded application**, patterns run on the horizontal axis, parallel to the floor.* This application is appropriate for pieces with longer widths as fabric rolls can run up to 100 yards, and can be somewhat more efficient in terms of minimizing seaming and wastage. The designer should carefully consider the orientation. Some fabric patterns are designed in a way that works only in one direction or it may clash with the visual features of the furniture to be upholstered. The stitching method for seams is another import-



Fig.09/39 The seams, buttoning, and nailhead trims utilized on the chesterfield sofa form a unique visual character.



Fig.09/41 Re-upholstery is both budget and environment friendly.

ant aspect of upholstery work. *There are many different **types of stitches** each with different functionality, strength, stability, and aesthetic quality* such as plain seams, topstitched seams, double-stitched seams, French (inverted) seams, lapped seams, piping, cording, and welting.

Re-upholstery is a sustainable way to approach upholstered furniture. The same furniture frame, suspension, and padding can be retrofitted repeatedly. Designers can find and buy old furniture for re-upholstering online, at auctions, in antique shops, or flea markets. Re-upholstered furniture can introduce a vintage feel and charm to a project and add interest by contrasting the more modern elements.



vid.09/16 Video on re-upholstering a wooden armchair.

SOFTGOODS

The term **softgoods** refer to textile products that lack the support of a rigid framework. This section focuses on the products featured in interior spaces, such as window treatments,

upholstery, bedding, and accessories. Apparel products are also considered soft goods.

Window treatments are design components that work in conjunction with a façade opening in order to control daylight and ventilation, modify the appearance, adjust the level of privacy, and alter the view. *The designer should focus on the following when specifying window treatments:* ①sunlight and glare control, ②solar heat gain, ③view and privacy, ④child and pet safety, ⑤user-friendly operation, ⑥aesthetic contribution, ⑦acoustical contribution, ⑧increased property value. **Shading coefficient** indicates how effectively a window treatment can reduce solar heat gain, typically expressed on a scale from 0 to 1, though these values are often between 0.1 to 0.8 for common products. The adjustability of the window treatment is fairly important as it can save part of the energy spent for cooling in the summer but also for heating in the winter.

There are various types of window treatments in the market, and depending on their functional-



Fig.09/42 Shutters are hard window treatments and they can block sunlight relatively well.



Fig.09/43 Different types of shades provide different functionality.

ity, combined applications are not uncommon. **Shutters** are hard window treatments covering the entire frame of the window, and by use of adjustable louvers allow sunlight, adjust airflow, and alter the view. **Blinds** feature slightly thinner and narrower slats. Sunlight, view, and airflow can be altered by adjusting the spacing and rotation of said slats. However, side leaks can be a problem since, unlike shutters, the entire opening is not covered. Blinds can be cheaper compared to shutters, also dependent on type and quality. Cleaning is a problem for both window treatments as the slats collect and retain dust. It is possible to integrate blinds in between panes of double glazed windows, preventing dust accumulation.

Shades feature a continuous fabric mounted on a rolling mechanism. The fabric can be rolled down to cover the window, though there are bottom-up versions as well. Shades are very useful in terms of filtering or partially allowing sunlight and controlling glare. Some versions of roller shades allow for varying the opacity by aligning two layers of horizontally striped fabric. Side leaks are a problem for shades as well.

Draperies are panels of loose fabric suspended from a track or traversing rod. Sunlight, view, and privacy are manually adjusted by pulling the drapery to the sides of the window. Draper-

vid.09/17 Video on drapery headers.

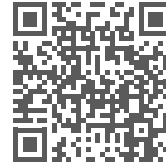

ies often feature pleating in order to increase volume, level of insulation, and add visual interest.

Fullness refers to the relationship between the actual width of the fabric and the desired application width to be covered. Fuller draperies have more volume, are visually more imposing, provide better insulation and sound absorption. Depending on the pleat type and desired fullness, the required drapery width can be **multiple times longer** than the actual application width. For instance, a simple box pleat would require a fabric 3 times the size of the application width, a ripple fold with shallow pleating would require at least 1.5 times. The measurement should also

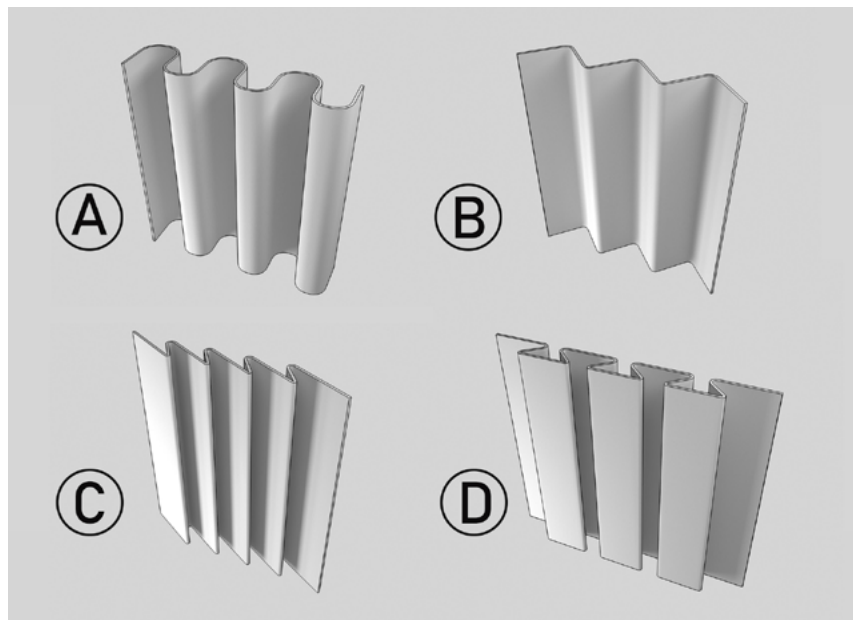

Fig.09/44 Common pleating types include rolling pleat (A), accordion pleat (B), knife pleat (C), and box pleat (D).

allow for seams and side hems. Fullness can be expressed in percentages. 120% fullness means that 120% longer fabric is used for a certain length. For example, to cover a 10' opening with 50% fullness 15', plus sewing and hewing allowances, need to be considered. A *“pleat to” dimension indicates that the designer wants a certain length of fabric to be pleated to a certain width.* In the case of a 48” fabric, pleat to 24” means 100% pleat fullness. The designer should consider that not all fabric patterns work with all pleating types.

Draperies can feature **lining** in order to enhance their various properties, such as increasing UV resistance, adding bulk and weight, increasing acoustic control, etc. For instance, a blackout lining can be a necessity in a conference room where a projector is utilized. **Hems** are the folded and stitched edges of drapery to maintain appearance while adding visual interest, can feature tapes or weights.

Acoustic draperies can be used as an alternative to or in conjunction with acoustic wall panel

vid.09/18 Video on the different types of hems.



applications. The thickness of the fabric, pleating fullness, and distance to the wall behind impact how effective the drapery will perform in terms of sound absorption. It should be noted that acoustic draperies are fairly ineffective at lower frequencies.

Curtains are similar to draperies, however, their construction is simpler and they don't feature mechanical hardware as they are not intended to be operated. A common example is café curtains covering only the lower half of a window. **Valance** is an ornamental piece of drapery covering the curtain rod or track at the top of a window. As a type of valance, **swag**, is a piece of fabric that is draped or hung in a cascading fashion across the top of a window. **Cornice** is a horizontal box-like rigid structure also covering



Fig.09/45 The many components of a drapery form a very specific look and ambience.

When considering custom-made window treatments, it is important to clarify that the workroom is **expected to take or retake** all necessary measurements.

the top. **Jabot** is a fabric draped or swagged on each side of a window.

Even though contemporary textile manufacturers are quite competent in terms of quality control, it is imperative that *all ordered fabrics **should be inspected** under bright light for defects, before starting the fabrication process.* Even if the fabric gets replaced without charge due to a defect, the lost time and effort for fabricating defective pieces can harm the overall project schedule considerably.

10

METAL

- *Core terminology for metals*
- *Metal alloys*
- *Corrosion, weathering, and patina*
- *Processing metals*
- *Finishing metals*
- *Ferrous metals*
- *Non-ferrous metals*

Metals are elementary substances that display high malleability, ductility, conductivity properties. They are opaque and exhibit a unique luster when the material is freshly exposed. The combination of these properties rendered metals valuable throughout history, they were extensively used for crafting tools as well as ornaments. Two highly useful properties of metals are ductility and malleability. **Ductility** refers to a material's ability to withstand and deform under tensile stress without failure – meaning the lack of unexpected and unwanted yielding, buckling, deflecting, or fracturing. This property enables metals to be drawn or extruded into useful shapes and profiles. **Malleability** is a similar property, however, this time the material can withstand compressive stress and deform without failure. This property enables metals to be pressed into thin sheets; most other materials can't perform as well as metals in sheet form. A material's strength in relation to its density, known as specific strength or **strength-**

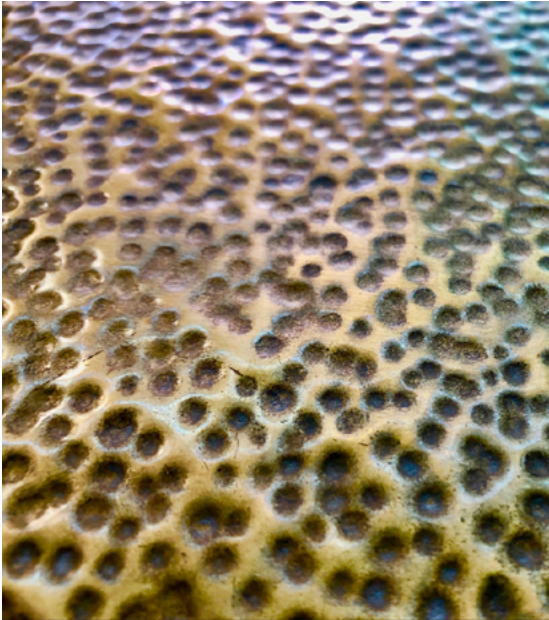

Fig.10/01 The malleability of metals enables the creation of hand-made textures such as hammered bronze.



Fig.10/02 304 series stainless steel alloy panels were used for the Gateway Arch construction.

to-weight, is another important property that renders some metals, such as aluminum, magnesium, and titanium highly useful, enabling components with the same exact strength to be manufactured at a much lower weight. *All metals are **highly recyclable**. Recycling is highly feasible unlike many other materials as the recycled content is equal or highly comparable to the virgin material.*

*High recycling potential also means that scraps carry **considerable value**; an important consideration when planning a demolition phase.*

Alloying is the melting and mixing of different metals as well as metalloids such as silicone or non-metal carbon, in very specific ratios to create a metallic admixture with very specific properties based on the interaction between base metals and the newly formed crystalline structures. For example, brass (copper+zinc)

and bronze (copper+tin). The resulting alloy inherits some desirable properties as well as some weaknesses, such as lower or higher melting point, corrosion resistance, luster, color, conductivity, formability, fatigue limit, price point. Metals are primarily used in alloy form and very rarely in pure form. Based on the formulation of elements and their percentages, there are hundreds of aluminum alloys for many different purposes, and tens of steel alloys, steel being an iron alloy itself. There's a "best" alloy for every specific design scenario.

Every metal and alloy feature a unique color. Metals can be polished to have a very smooth and reflective surface, they can also be textured

vid.10/01 Video on the intricacies of various metal alloys.



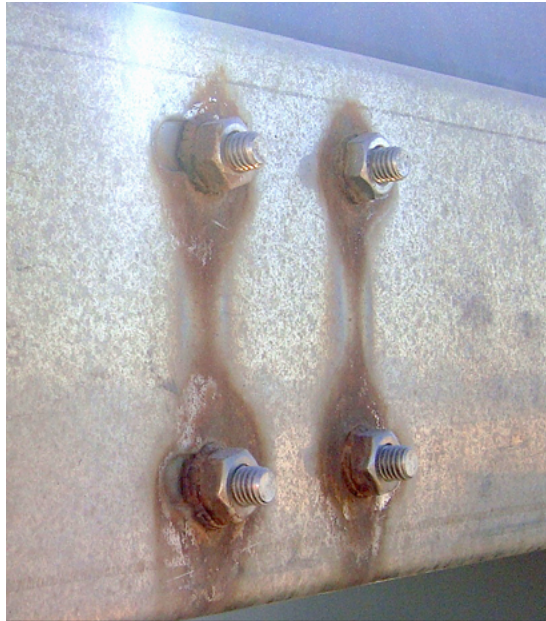

Fig.10/03 Galvanic corrosion can even happen between stainless steel (nut&bolt) and mild steel (beam).

owing to their high malleability. When exposed to elements metals tend to corrode. **Corrosion** is a natural process, during which the metal is attempting to return to a more stable natural state. There are many types of corrosion, such as **pitting** where metal corrodes from a localized point that eats into the metal fairly rapidly, stainless steel is very susceptible to this type of corrosion. Uniform corrosion is another type, referring to an even corrosion on a large area on the metal's surface. Impurities in a metal's microstructure can cause a phenomenon called inter-granular corrosion. **Galvanic corrosion** manifests when an electrical current, known as galvanic current, flows through liquids, vapor,

via.10/02 Video on the construction of the Statue of Liberty.

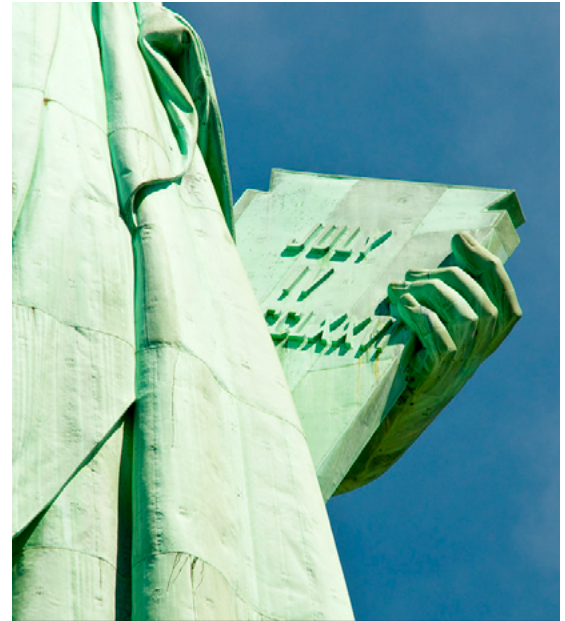

Fig.10/04 The unique light green patina of the Statue of Liberty showcases the impact of site conditions.

humidity, or any conductive substance between two dissimilar metals; dissimilar in terms of the relative difference in nobility and electrochemical potential. The process erodes the metal with the lower galvanic number, such as aluminum and zinc. For example, as soon as a current runs through aluminum and steel, aluminum will corrode, unless an insulative coating is applied.

Metals that are highly reactive, such as copper, zinc, or iron, will start developing an oxide layer, commonly referred to as patina, shortly after being exposed to the atmosphere. Patina can be very desirable as it protects the metal underneath while providing a unique visual quality. For instance, the greenish film developed over its copper cladding gives the Statue of Liberty its unique color. Patina develops over time, as the metal goes through oxidation stages with different visual characteristics until an equilibrium is reached. Copper's patina can develop over 10 years, whereas aluminum or zinc develop patina

within a year. Gold never develops a patina. It is also possible to expedite the patina development process via the use of various chemical coatings. The resulting products are referred to as **pre-weathered**, very useful for achieving the desired look quickly, and very helpful for matching color and texture during repairs while minimizing visual inconsistencies. However, the designer should also consider that the atmospheric conditions, such as the salt present in the environment or unique weather conditions affect the natural development of the patina and the result will be more authentic.

Metals typically require **milder cleaning methods** in order to minimize damage to patinas and coatings. There are purpose cleaning solutions available on the market but oftentimes dusting with a clean cloth, vacuuming, and mild cleaning chemicals are appropriate and sufficient.

Most metals show **anti-microbial** properties; some more intense than others, like copper and silver. This is achieved by metal ions disrupting the vital processes of microorganisms and preventing reproduction.

PROCESSING METALS

Metalworking processes can be broadly categorized into forming, cutting, and joining. Multiple processes may be involved in the fabrication of a single metal component. Metals can withstand plastic deformation before breaking, thanks to their malleable and ductile nature. This enables cold forming techniques such as bending, rolling, extrusion, punching, stamping, drawing, spinning, etc. to be utilized. **Extruding** involves forcing metal through a shaped aperture to achieve a lengthy component with the desired profile. Large roller presses can shape metal into a profile or flat plane. Metal fibers can be drawn with a similar technique. **Casting**

involves pouring molten metal into sand, wax, plaster, ceramic, or die cast molds. Metals that are highly fluid in molten state, and with low viscosity and die shrinkage are the most appropriate for casting, especially if complex geometries and thin wall sections are required. Some highly suitable metals are zinc, copper, cast iron.

Forging is heating and reheating cold metal and shaping it with presses, hammers, and other tools. The metal piece that is being worked on is called a **workpiece**. While the metal is being worked it becomes harder as the molecules are dislocated, this process is called strain hardening. **Annealing** is a heat treatment method to attain a more workable workpiece, by relieving stress and increasing ductility. The metal is heated to its recrystallization temperature and slowly cooled in a furnace. **Normalizing** is another heat treatment similar to annealing, however, the cooling process happens in room temperature. This is a cheaper process but it might create slight impurities and defects. **Quenching** involves rapidly cooling a workpiece in water, oil, or stream of air to increase hardness. **Tempering** is performed by heating the quenched workpiece to a certain temperature below the critical point and cooling by exposing



Fig.10/05 Compressing and shaping metals increases their strength and hardness while decreasing their malleability and workability.

vid.10/03 Video on heat treatment of metals.

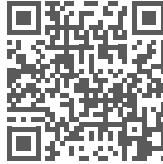

it to still air. This process reduces excess hardness and restores some ductility, rendering the workpiece stronger.

Milling is a subtractive forming process. It involves shaving off material using rotary cutters to achieve the desired shape. Milling can be done with manual or digitally controlled (CNC) tooling machines. There are a variety of CNC or computerized numerical control machines available, the most important feature being the number of axes and reach available to control the cutting tool. This feature determines the types of metal that can be tooled and the size and complexity of forms that can be achieved.

Latheing is similar to milling with one crucial difference, during latheing the actual workpiece

vid.10/04 Video on latheing a cube within a cube.



is rotating rather than the cutting tool itself.

Additive manufacturing is also possible with metals. Various metals such as titanium and aluminum can be **3d printed** with techniques such as selective laser sintering and laser metal deposition, even though the resulting metal component would not perform as well as a milled counterpart in demanding situations.

Gauge, or gage (ga), is a measurement indicating the thickness of a sheet metal. Thicker sheets are referred to as heavy gauge and the opposite as light gauge. The larger the number the thinner the sheet is; 10ga is 84% thicker than 16ga. One problematic aspect of gauge is, for different types of metals a specific gauge can refer to a different sheet thickness. For example, 12 ga steel is 0.105 inches thick, whereas 12 ga aluminum sheet is 0.0808 inches thick. The thickness can also vary between suppliers. Sheets thicker than 0.25 inches (6mm) are referred to as plate. A foil is sheet metal with a thickness of less than 1/128 of an inch.

There are various ways to join two pieces of metal and form strong bonds. Welding, soldering, and brazing are based on the principle that it is possible to melt pieces of metal to form a connection by applying focused intense heat to multiple points on their shared edge, essentially fusing them. The main difference between each of these three processes is the working temperature and if the base material or filler material is melted or not. It is also possible to weld plastics and wood, though the process, tools, and temperatures are vastly different. **Welding** involves melting the base metal at incredibly high temperatures (10,000 to

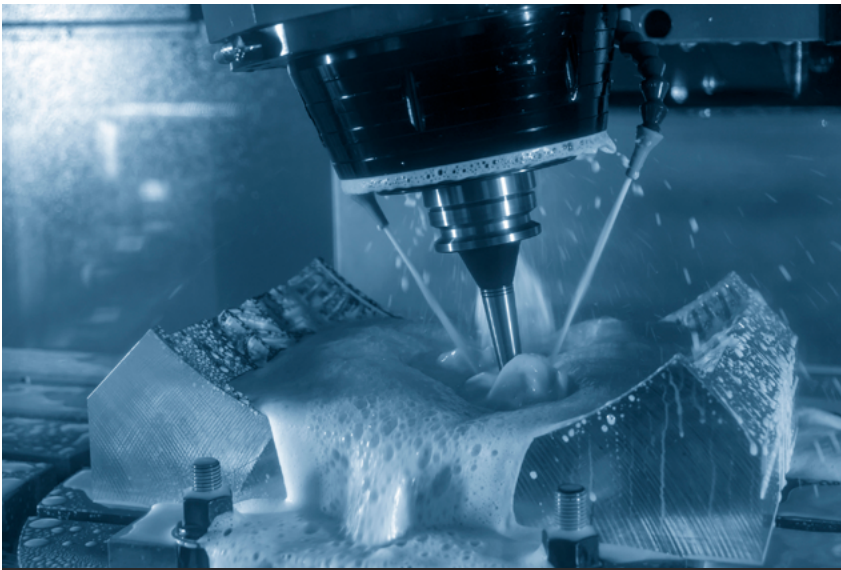

Fig.10/06 The impressive reach of a 5-axis CNC milling machine enables intricate 3d details to be fabricated.

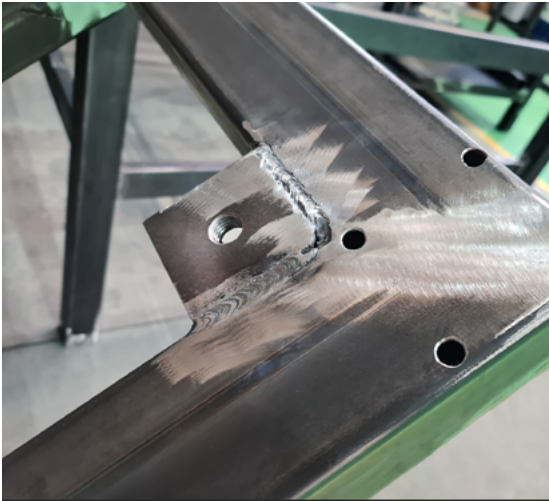

Fig.10/07 Welding is suitable for demanding applications, such as lug joints.

50,000°F). Welded joints are stronger than the other two methods and can join thick sections, appropriate for high-stress load-bearing applications. There are different types such as arc-welding, electron or laser beam-welding, and friction-welding. Some types of welding require a filler material and others don't. Welded sections require heat treatment to relieve residual stress built-up during the welding process. **Soldering** is done at lower temperatures (below 800°F), a metal alloy is melted between workpieces. This filler metal flows into the joint, cooling and binding workpieces. The process bears similarities to welding, with the exception that the base metal stays intact, the mechanical properties of the base metal are protected. Soldering is not appropriate for load-bearing applications, commonly used in jewelry and electronics. Welding requires the welded parts to be similar, however, there's no such limitation for soldering. **Brazing** is very similar to soldering but performed at slightly higher temperatures (above 800°F), not so high that the base material is melted. The joints produced are stronger than soldering, but they still won't be suitable for demanding applications. It is important to consider the types and



Fig.10/08 Riveting is a time consuming process, harder to conduct on-site, therefore a mixture of rivets and bolts is not an uncommon sight in construction.

properties of metals, specifically the alloys to be used as workpieces, the type of load expected, the connection strength required, worksite, budget, and schedule limitations.

It is also possible to join metals with mechanical fasteners. **Bolting** involves joining, or essentially clamping, two plates of metal with large bolt fasteners; bolts can be pre-tensioned to increase strength. Bolts are considered temporary; this means removing them won't destroy the fastener. Loosening can happen but it is not common. **Riveting** involves a rivet, a heated steel rod with a cap, going through two metal plates to be permanently secured by forcing it into a die on the other side. Riveting usually involves more fasteners on the surface and the process is time-consuming, however, higher joint strength is achieved. Mechanical fasteners are useful for assembling prefabricated elements



vid.10/05 Video on hydraulic hot riveting.

on-site, as opposed to welding on site which can be inconvenient and expensive. A strong bond is attained not only through the shank of the fastener but also through the friction between large, overlapped surfaces. Increasing the number of fasteners helps spread the load.

Adhesive bonding is also an option for metals. *Epoxy and acrylic **structural adhesives** work best between metal to metal bonding, as well as for bonding other materials to metals.* Adhesives are useful for hard-to-access points, for quick on-site corrections, and when mechanical fasteners or weld lines need to be hidden. They are not as strong or reliable to replace welding or mechanical fasteners in demanding applications.

FINISHING METALS

*There are three overarching metal finishing types: mechanical, chemical, and coating, as outlined in the **Metal Finishes Manual** published by the National Association of Architectural Metal Manufacturers (NAAMM). The strength,*

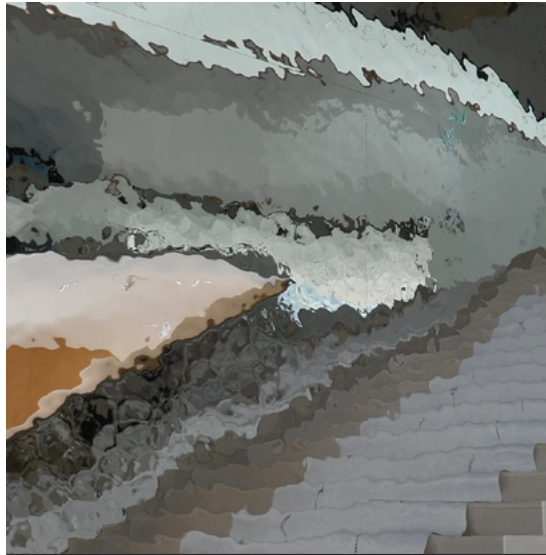

Fig.10/09 Slight wavy texture on polished stainless steel surface can create unique reflections.

durability, and price point that can be attained with each finish type is different, primarily based on the metal or alloy to be finished as well as the task the finish is specified for.

*Common **mechanical finishes** include grinding, honing, lapping, polishing, and buffing. These usually involve creating a gradually smoother and bright, reflective specular, satin, or fine to coarse matte finish by applying increasingly finer abrasives. **Brushing** involves abrading the surface in a single direction to create a distinctive linear pattern. **Particle blasting** is abrading the surface by means of blowing coarse particles to the metal surface to create more diffuse reflections. Some more malleable sheets of metal can be hammered to create a more textured look, great for hiding surface defects. This technique is commonly used for copper hoods.*

***Abrading the surface** can create slight distortions on the material and it can be detrimental to the metal's ability to resist corrosion and aging.*



Fig.10/10 Brushed stainless steel is a very common finish for home appliances.

Chemical finishes include acid etching, hot and cold patina solutions, chemical weathering, and controlled corrosion via oxidizing agents. Some of these methods are used for surface cleaning, preparation, or as intermediary steps for other finishing methods. For instance, a chemical conversion coating or chem-film can act as a protective intermediary surface, or it can be a standalone finish. **Electropolishing**, or anodic polishing, is a great tool for finishing oversized or complex and delicate pieces by dissolving the metal surface in a very controlled way. Chemical finishes can create noticeable visual defects on exposed welded joints, and they may not be a good choice without careful detail design.

Coating processes involve depositing material over the surface of the metal either through brushing, spraying, hot dipping, or various chemical, magnetized, electrical, methods. PU coating, vinyl foils, powder coating, lacquers, waxes, enamels, galvanizing, electroplating, or clear sealants are all considered in this category. The extra layer of material creates an important barrier against weathering and corrosion while improving the ability to clean and maintain the surface. PU film application or lacquering can be used on metal surfaces to lock and retain the desired appearance, stop weathering, and provide a bright sheen. Anti-ice, fire resistance, or hydrophobic qualities can be achieved by various coatings. **Anodizing** is an electrochemical coating process that involves forming a durable anodic oxide layer on the metal surface. This finish can be transparent, translucent, or opaque, and it can be given a unique color and tint. Aluminum is highly suitable for anodizing; a finish popularized by Apple® products. Ferrous



Fig.10/11 Anodized aluminum cladding can feature a wide range of colors.

metals are difficult to anodize and the results are not as durable. **Enameling** is fusing the metal surface with glass frit. A large selection of lively and lasting colors as well as a smooth and resistant surface can be achieved. On the other hand, enameling is often prone to cracking and chipping. **Electroplating** involves running an electric current through a metal to coat it with a thin but consistent layer of another metal, through a process called electro-deposition. The commonly known chrome plating technique is one example. This process creates a durable, bright, and mirror-like finish but byproducts of the process, including hexavalent chromium residue are known to be persistent environmental pollutants and pose great health risks.

Vid.10/06 Video on powder coating metal components.



Vid.10/07 Video on anodized aluminum finish.



FERROUS METALS

Ferrum is Latin for iron (Fe) and ferrous refers to metal alloys that contain iron. There are many classifications of metals, however, *based on the significance of iron for the construction industry, the **ferrous vs. non-ferrous** classification is the most useful for spatial design.* Iron is among the most abundant elements; 35% of earth's total mass and 85% of the earth's core is iron. During ancient times meteoric iron was discovered occasionally; a rare and valued iron type that was stronger due to its nickel content. As the earliest example of metal working dating back to 3200 BCE, Egyptians used meteoric iron to craft cylindrical beads. The archaeological artifacts suggest that a number of civilizations learned smelting and refining iron ore between 1600 and 600 BCE, making various tools, weapons, and ornaments. Over the centuries blast furnaces were developed for large-scale iron manufacturing but only during the mid-18th century iron manufacturing reached an industrial scale and found widespread use in building construction.

The addition of carbon increases the strength and hardness of iron but reduces ductility and ability to be welded. ***Wrought iron** has a low carbon content of less than 0.1% and it is ductile, can be wrought to shape. On the other*



Fig.10/12 Meteoric iron was one of the first types of metal to be processed.

*hand, **cast iron** has a high carbon content of more than 2%, more suitable for molding. **Crude iron**, also known as pig iron, is an intermediate product that is used in the production of other ferrous products such as steel or wrought iron. It has a very high carbon content, up to 4.7%, very brittle and not very useful. Starting around the 18th century **cast iron** could be produced in large quantities and in a consistent, reliable, and convenient manner that it was commonly used as a structural component. The high fluidity of molten cast iron, relatively low casting temperature, high-quality surface finish, and reusable casts render it a suitable material for fabricating detailed ornamentation. Doors, corner blocks, columns, and other building components can be manufactured this way, however, the resulting product is substantially heavy. The crystal palace was an important example of a cast iron structure, which was destroyed in a fire in 1936, 85 years after its opening. **Wrought iron** on the other hand is relatively soft, strong, and malleable thanks to its low carbon content. However, its load-bearing capabilities are somewhat limited. Eiffel Tower is the tallest wrought iron, specifically of puddled iron subtype, structure. Iron in general is unstable when exposed to the atmosphere or most acids, it would corrode readily and rapidly. This is the reason why the Eiffel Tower is painted every 7 years.*



Fig.10/13 The Eiffel Tower is the tallest wrought iron structure, at almost a 1000ft.



Fig.10/14 The original Bessemer converter design was a huge improvement over blast furnaces.

Steel is another iron alloy with a carbon content between 0.1% to 2%, basically between wrought and cast iron. The invention of the Bessemer process, or conversion, in 1855 enabled steel to be manufactured from low-grade ores in industrial quantities. Following the great Chicago fire in 1871, there was a rising demand for rapid construction and steel was extensively employed. Rand McNally Building in Chicago, built in 1889, was the first steel-frame skyscraper.

There are 3 common grades of steel: carbon steel, stainless steel, and tool steel. Each category contains several sub-categories, such as mild (low-carbon) or high carbon steel or, 200, 300, or 400 series stainless steel alloys; each one with different properties ranging from high castability, ductility, corrosion resistance, etc. **Stainless Steel** contains at least 10.5% chromium, which in turn develops a corrosion-resistant self-healing chromium-oxide film when exposed to oxygen. Stainless steel is highly suitable for industrial equipment where corrosion resistance, anti-microbial properties, and

cleanability are required in addition to strength and durability which can already be attained by carbon steel. Professional kitchens often feature stainless steel countertops, one of the few National Sanitation Foundation (NSF) approved materials for commercial food preparation. Stainless steel is almost completely corrosion resistant. Salt flakes, cleaning agents, or rigorous cleaning practices with abrasive tools can cause the protective film to be damaged, which might in turn cause stainless steel to corrode inward, a phenomenon known as pitting; it starts as very small black or brown dots on the surface. It is possible to improve resistance against pitting by adding nitrogen to the alloy mixture.

Steel manufacturing causes one important sustainability concern, *the process of removing the impurities in iron to make steel requires very high temperatures, which results in **very high embodied** energy and a significant carbon footprint.* However, steel is also very recyclable, utilizing around a quarter of the energy required to manufacture virgin material. Furthermore, steel is magnetic and it is relatively easy to separate from mixed waste. Another sustainability issue for steel is the dangerous gases and particles produced during manufacturing and later processing and finishing procedures.

Steel is among of the most commonly utilized metals in the building sector, including interiors, owing to its high strength, durability, and reasonable price point. Steel beams are fundamental components of steel frame construction. *Common types of structural steel such as wide flange, I-beams, and structural channels, are manufactured via **hot working** techniques such as rolling, extrusion, forging.* Steel is easier and

vid.10/08 Video explanation of how pitting occurs.





Fig.10/15 Trusses enable longer spans to be covered efficiently.

cheaper to form when hot, and it gains strength and durability as it is being worked. However, there can be internal stresses, weak spots, dimensional tolerance problems due to inconsistent cooling. Trusses are another structural component comprised of interconnected triangular units engineered to efficiently distribute vertical and horizontal forces throughout their framework. **Cold rolled** steel, features a better finish and minimal dimensional tolerance problems, appropriate for more accurate jobs. Even though it is more expensive, the process puts a lot of stress on the material, improving mechanical strength properties. Steel can be extruded into various profiles and then can be welded. Steel sheets can also be pressed or stamped, and reshaped with the help of a die, e.g. stainless steel sinks, appliance panels, pans, pots.

Rebars, short for reinforcement bars, are manufactured from mild steel and used in the construction of reinforced concrete. Rebars are laid to form a lattice within a mold referred to as formwork, within which concrete mixture is poured. Reinforced concrete is a highly effective composite material due to the fact that mild steel has a very similar coefficient of thermal expansion to concrete. Moreover, the specific pH of the concrete wrapping steel rebar keeps them from corroding. However, embedded steel reinforcement can corrode within the concrete

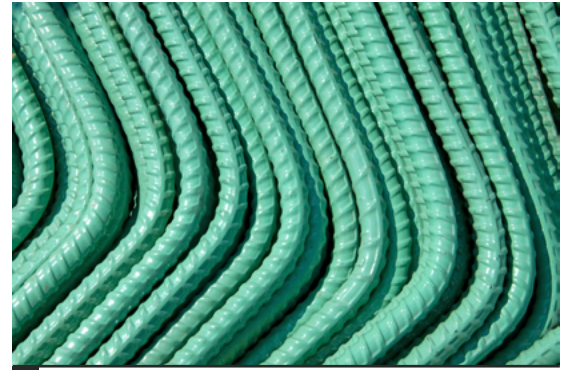

Fig.10/16 The epoxy coated, ribbed rebars are appropriate for demanding applications.

in time, causing failure. Rebars can be epoxy coated, galvanized, or simply manufactured from stainless steel to prevent this phenomenon. The surface of mild steel bars is smooth, but high-strength tensioned rebars can feature ribs, threads, and other details to increase bonding.

Steel has high finish retention and there are a multitude of specialized finishes available for various purposes, including specific interior applications. Besides being used as framing members, polished or brushed steel is commonly used as column covers or wraps. Patterns of holes, slots, or decorative shapes can be punched or stamped out of sheets of metal, producing perforated panels. In addition to the finishing procedures utilized in other metals, galvanizing is a very significant and common finish for Steel. In simple terms, **galvanizing** refers to coating steel with a zinc film. Zinc provides what is known as sacrificial protection, which means that zinc will preferentially corrode even though the metal underneath is exposed to an extent. Galvanizing can also act as a foundation for paint, it is also possible to apply a protective topcoat of corrosion inhibitor. Galvanized steel sheets are also a commonly used material for manufacturing cold-formed building components such as studs, braces, girts, and railings. Corrugated metal decking is one such material; it is profiled to increase resistance

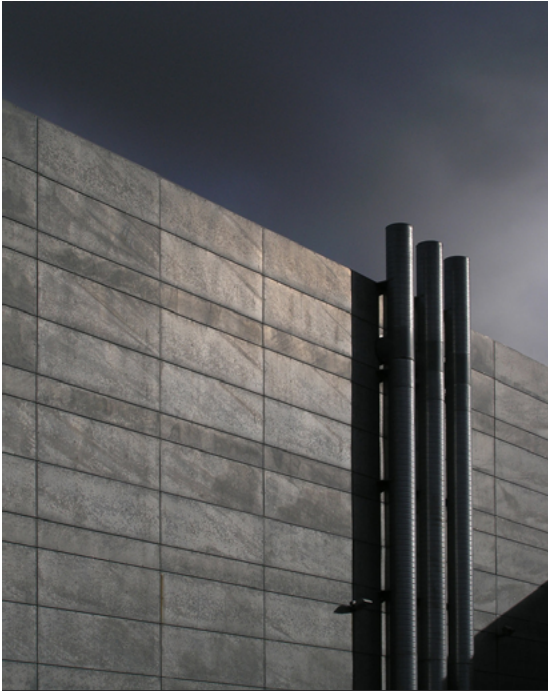

Fig.10/17 Galvanized steel features a highly characteristic flaky gray appearance.

against compression loads, placed over joists in order to support a concrete fill or a plywood substrate. Corrugated sheets are also used for supporting roofing materials and insulation.

Weathering steel, commonly known by the trademark **COR-TEN**, is a metal panel or sheet product that is basically a weathered steel alloy that has a distressed, rusted look. It is very durable and requires minimal need for maintenance. Nevertheless, this finish may not exhibit stability in damp and caustic environmental conditions, such as near coastlines. The material can be coated with polyurethane (PU) film to protect the finish from further corrosion.



Vid.10/09 Video on the hot dip galvanizing process.



Fig.10/18 Weathering steel panels introduce unique earthy colors and natural texture variations.

Even though the melting temperature of steel is 2600 to 2800°F, the material loses its stiffness and strength way before melting. Prolonged exposure to temperatures above 1000°F can render steel plastic, weak, and highly prone to deformation and failure. Therefore, **fireproofing** structural steel is required especially for high-risk construction, such as high-rises and institutional buildings. It is possible to apply intumescent paint or spray on vermiculite for fireproofing, however, these finishes are relatively delicate and might need additional protection from abrasion, impact, and weathering.



Vid.10/10 Video on steel fireproofing.

NON-FERROUS METALS

Non-ferrous metals refer to metals other than iron, or iron alloys. These metals can feature some unique desirable properties such as higher malleability, lower melting temperature, high castability, non-magnetism, corrosion and tarnish resistance, or simply unique color and sheen. Non-ferrous metals have been used for design applications throughout history, mainly as decorative components. The first known use of copper to make pendants dates back to around 9000 BCE in the Middle East. Around 3300 BCE, Sumerians were the first to alloy copper with tin, which they used to make bronze religious statues.

ALUMINUM • Approximately 8% of the earth's crust contains aluminum, making it the third most abundant element on earth, and the most abundant on earth's crust. Aluminum is always found bonded to other elements, commonly in bauxite form and the extraction and refinement process requires significant energy. *Even though aluminum has very high embodied energy, it is also **extremely recyclable**.* The recycling process requires only 5% of the energy needed

to produce virgin material and there is virtually no difference between virgin and recycled material. However, there are several other issues with aluminum manufacturing with regard to environmental impact. The ore bauxite is extracted through open pit mining, which inevitably causes land and ecosystem destruction. The electrolysis-based aluminum refinement process is highly energy-intensive and uses a lot of water. The chemicals used in the process create a mixed residue called red-mud that is not water-soluble and potentially toxic.

Aluminum boasts superior strength-to-weight, is highly pliable and machineable, in addition to being chemically inert with no toxicity. Furthermore, it is resistant to corrosion owing to the rapidly forming oxide film when exposed, the only exception being alkaline conditions (contact with mortar, cement, etc.) where corrosion rate rapidly increases. Aluminum is often used in alloy form. The base metal aluminum can be combined with copper, nickel, magnesium, iron, titanium, silicon, tin, and zinc to form alloys.

Aluminum has a wide range of uses in the construction industry; it is used for structural members, paneling, cladding, roofing, window



Fig.10/19 Red mud is a toxic byproduct of virgin aluminum refinement process, source of serious environmental concerns.

and door frames, railings, hardware, and even flooring. Sheet aluminum can be **folded** to attain structural strength and stability without adding weight, a principle often used in framing members. Aluminum louvers and window blind slats are other popular uses. Aluminum can be foamed, which actually involves creating a cellular structure with numerous gas-filled bubbles. Aluminum can also be woven and used as wall finish. Aluminum composite panels (ACPs) are lightweight but sturdy construction materials, a low-density core such as foamed metal or honeycomb panel can be sandwiched between two sheets of aluminum to achieve extremely high strength-to-weight ratio, a versatile method commonly utilized in the aerospace industry. Aluminum is totally impervious to light and moisture, chemically inert, and non-toxic with a modest price point, making it highly suitable for food packaging.

COPPER • *Copper is a pliable and ductile metal with high castability.* Pure copper displays excellent conductivity and corrosion resistance. Copper has been and is still being used for electrical wiring, and it has been used for plumbing and fittings in the past. Copper does not corrode in

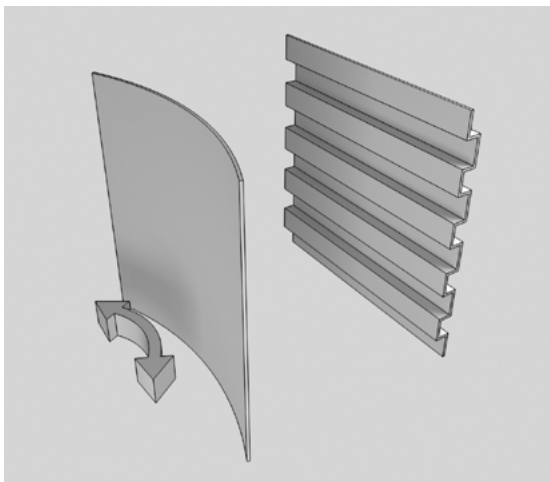

Fig.10/20 Folding, corrugating, and ribbing increases strength of the sheet metal by creating resistance.

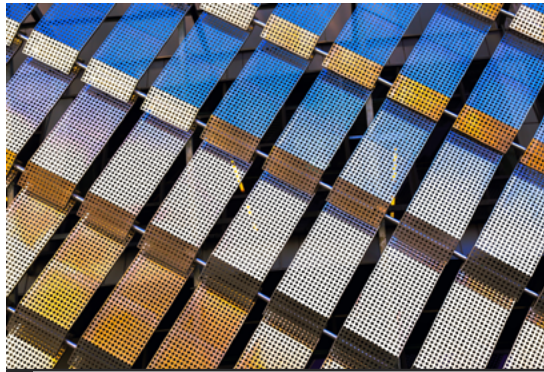

Fig.10/21 Perforation decreases the weight of a panel, allow passage of light, and improve aesthetics.

alkaline conditions therefore prolonged contact with concrete and masonry is possible. When exposed to the atmosphere and elements, copper can develop a patina that gradually transforms from a brown to a light green color, typically over the course of several decades. Copper has two very common alloys: bronze containing primarily tin, and brass containing primarily zinc. Bronze has a lower melting point thanks to added tin. When molten, **bronze is highly fluid making it a great choice for intricate casting**, one reason for the countless number of bronze statues. Unlike

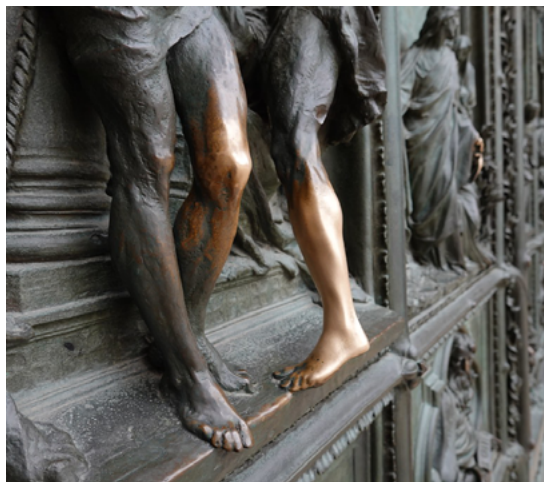

Fig.10/22 Constant visitor contact prevented the development of patina, revealing the true color of bronze.



Fig.10/23 Copper is suitable for contact surfaces where hygiene is a major concern.

the pinkish color of bronze, **brass** has a color and luster resembling gold. The strength and workability of brass can be modified by adjusting the ratio of aluminum and zinc, respectively. Copper mining leads to extremely **hazardous waste products** containing arsenic, lead, antimony, and mercury. However, copper itself displays antimicrobial properties and commonly used in medical instruments and healthcare interiors. Bronze has uses in other interiors too, mainly utilized for decorative purposes on components such as lighting elements, furniture details, railings and balusters. Copper tiles are also available on the market.

GOLD & SILVER ● **Gold and silver** have been associated with wealth and nobility throughout history, they were used for coinage, and high-value items such as crowns, decorative hilts, etc. This is mainly due to the relative scarcity of these materials, ease of smelting, resistance to corrosion and tarnishing, as well as a unique color. All exposed metals lose their appearance to varying extents, however, gold is an exception in that it stays intact without corroding or tarnishing.



Fig.10/24 Gilding has been a feasible way to use gold in interior spaces.

Both gold and silver are highly malleable and moldable, very popular in jewelry applications. Due to their high costs, **coating and gilding** are popular ways to cover decorative elements in interior space. The mining processes are detrimental to the environment, for both silver and gold. Furthermore, the use of chemicals such as cyanide and mercury during the process can be extremely polluting. Both metals are highly recyclable and owing to their high value, almost all gold and silver is recycled.

CHROMIUM & NICKEL ● **Chromium** is a durable and lustrous metal commonly used in alloys and plating other metals due to high polishability and abrasion resistance. When exposed to oxygen, chromium rapidly develops a protective coat. There are three states of chromium: divalent, the unstable state; trivalent, the less toxic state; and hexavalent, the highly toxic state known to be a carcinogen. Chromium is an important component in stainless steel alloy, and commonly used for chrome plating, also used as a chemical component in the leather tanning process. Besides steel, other metals such as aluminum,



Fig.10/25 Embossed tin ceiling tiles can retain intricate detail and introduce a unique sheen.



Fig.10/26 Zinc panels are commonly utilized in contemporary architectural facades.

copper, zinc, magnesium, and titanium can all be chrome plated. **Nickel** is a bright gray metal, pliable and ductile. It receives polish and maintains clarity well. Nickel and chrome can be plated on the metal in succession to produce a shiny, durable, and corrosion resistant finish.

TIN • **Tin** is a buffable silvery metal with subtle bluish tint, commonly used to form alloys or for protective plating. Tin is also used in decorative elements such as ceiling, wainscoting, cabinetry panels, etc.

TITANIUM • **Titanium** is stronger than steel at almost half the mass, able to provide superior strength-to-weight. Titanium is very hard to refine and very unstable after refinement. As a result, its embodied energy is high and workability is low. Titanium tiles are available for facades and interior spaces in a wide range of colors. These are often manufactured from recycled content and are lower grade. The famous Frank Gehry building Bilbao Guggenheim Museum features titanium cladding throughout its exterior.

ZINC • **Zinc** is bright bluish-silver when freshly cast; through weathering it gains a dull dark gray, and later black tint. Even though a strong, ductile, and durable metal itself with great castability. In the construction industry, much of zinc is used for galvanizing or plating. Galvanizing involves coating iron or steel with zinc layer to prevent oxidation and minimize wear. The coating is distinguishable by the matt gray spangled or flaky texture. There are different methods of application such as hot-dip galvanizing and electro-galvanizing. Depending on the environment, zinc corrodes 1/10th or 1/40th of the speed of steel, however, if the barrier is damaged an under-film corrosion can spread rapidly. Zinc also protects steel by sacrificing itself through cathodic protection, this ensures that when steel is exposed it is still protected to an extent. Zinc can quickly develop a matte gray patina to protect itself, even as a layer on top of steel. Normally it takes 6 to 12 months for the patina to develop but pre-weathered zinc panels are available in the market.

11

PLASTIC

- *Polymers and plastics*
- *Synthesis and key additives*
- *Environmental impact of plastics*
- *Resin identification code and recycling*
- *Common thermoplastics and thermosets*
- *Plastic manufacturing methods*
- *Composites*
- *Polymer products specific to interiors*

The term **polymer** refers to chained large molecules composed of repeating the same monomer subunits. Polymer and plastic are used somewhat interchangeably, however, plastics are a sub-family of materials polymerized from basic petrochemicals such as ethylene, propylene, butylene, etc. Polymers are the overarching category and not all polymers are plastic. For instance, silicone is classified as a polymer, but it is not a plastic. Polymerizing is an energy intensive process where the basic building blocks called monomers are chained to form complex plastics. For example, several thousand ethylene molecules can be chained together via a chemical reaction to form polyethylene, or tens of thousands of ethylene molecules can be chained to form high-density polyethylene (HDPE). *Plastics are sometimes referred to by popular trademarks*, such Plexiglas for acrylic, Teflon for polytetrafluoroethylene, Cellophane for cellulose-acetate, Fiberglass for glass fiber reinforced polymer (GFRP), and Nylon for polyamide.



Fig.11/01 Patented in 1859, celluloid became synonymous with film stock.



Fig.11/02 Acrylic is commonly referred to as Plexiglas, Lucite, Acrylite, or Perspex.

Resin refers to a viscous blend of polymers and additives that can be spread, sprayed, molded, or foamed and transformed into its final form through cooling or curing. Resin is not a type of plastic, but rather an intermediary state that the plastics can be in. Epoxy resin is well known and sometimes referred to as just “resin” but most plastics can be in resin state, such as polyester resin, acrylic resin, vinyl chloride resin, melamine resin, polyolefin resin, etc.

The rapid development of a large variety of synthetic products since the mid-19th century changed manufacturing possibilities, and consequently, how products and interior spaces were designed. **Celluloid** was the first synthesized thermoplastic, patented in 1859. It was transparent, moldable upon heating, and retained form when cold; offered great versatility, surpassing all-natural alternatives. **Rayon** was regenerated cellulose developed to imitate silk fiber, patented in 1894. The invention of **Bakelite** in

1907 marked the debut of fully synthetic materials. By 1970, plastics had become integral to a wide variety of industries. Today there’s a plastic component present in almost every product and interior space.

Polymers are highly versatile. There’s a litany of polymers available with vastly different properties, it is also possible to further modify them with the inclusion of pigments, plasticizers, fillers, stabilizers, and other types of additives; enhancing their mechanical performance, impact resistance, moldability, fire-resistance, surface finish, etc.

Pigments are added to determine the color of the plastic. The inherent transparency and surface quality of the resin determine the saturation and vibrancy of the resulting color. Various additives can be used to further enhance color properties, for example, clarifiers can be used to enhance transparency. As opposed to paints and coatings, added pigments are much more durable as they are diffused throughout the plastic body.

Plasticizers are added to increase the flexibility and strength of the material. For instance, PVC is inherently a brittle plastic, however, with the addition of plasticizers it acquires flexibility,

Vid.11/01 Video on polymers and the synthesis of plastics.



which helps vinyl to be much more durable, and in some cases more workable. The basic properties attained with plasticizers can be lost over time as the additive can evaporate or leach as it migrates towards the material surface. This behavior also causes serious health issues.

Fillers/Extenders are added to give the material bulk and strength. They are useful for decreasing raw resin consumption, therefore, lowering costs. However, they are also useful in increasing moldability, stability, and strength. In some cases mineral fillers can imbue the plastic with fire resistance. Glass fibers are one such additive. In fiber-reinforced plastic applications it can give polypropylene (PP) bulk as well as help the material to keep itself together and sustain heavier loads and impacts.

Stabilizers are used for increasing the useful life of plastics by slowing down degradation, ensuring colorfastness, increasing UV resistance, inhibiting oxidation, etc. They are also useful in minimizing manufacturing defects and in some cases contribute to recyclability along with compatibilizers. For example, without stabilizers (specifically HALS) common polyolefin impurities can cause excessive UV light absorption and degradation.

Additives have both positive and negative implications for the recycling process; they **contribute** by protecting the original resin, restoring



Fig.11/03 A heap of PVC waste including rigid and flexible components, waiting for separation.

*diminished qualities, eliminating inconsistencies, making sure that recycling stays feasible; on the other hand, they **complicate** the waste separation process which in turn can deteriorate the recycled product quality.* The variety of additives present in contemporary products is one reason why PVC recycling is limited.

Plastics can be **alloyed** like metals, by mixing multiple resins with desirable properties. For instance, the impact strength, flame resistance, and mold shrinkage of acrylonitrile butadiene styrene (ABS) can be improved by mixing it with PVC. Even though alloying plastics improve performance and visual/tactile qualities, the resulting mixture is even harder to recycle.

Over the decades the environmental impact of plastics became well documented and better understood. Plastics are a byproduct of the oil industry, accounting for 9% of the total oil consumption. This slowly depletes oil and natural gas resources, which are finite. Initial polymerization, as well as further processing of plastics, require intense heat, resulting in high embodied energy. Most importantly, the natural degradation of plastics is very slow, causing continuous debris build-up in varying sizes, from large containers, fishing nets, broken-off chunks, or even microscopic particles. **Microplastics** are tiny pieces of plastic, specifically less than 5mm (3/16") in length, that were broken down through oxidation, UV exposure, and mechanical forces. Although less common today, a number of cosmetic products like some face scrubs and toothpastes contain already broken down microplastics which are flushed directly down the sink and easily mixed into waterways. According to the US National Oceanic and Atmospheric Administration (NOAA), microplastics are the most common type of marine debris today. Many research indicates seafood as a common means for ingestion of such particles by humans, which can cause gastrointestinal obstruction. Fat and water-soluble plastic components have the potential to impact immune and endocrine systems,

though there's need for additional scientific evidence for a certain conclusion. However, the health detriments of plastics stretch further. As previously explored, synthetic materials tend to emit VOCs and leach chemicals, a process that can be sped up with the increased presence of heat and humidity. *Plastic particles and fumes are notorious **asthma triggers***. Formaldehyde has a bad reputation for the high level of VOC emissions, aside from being a known irritant and carcinogen with developmental toxicity effects. Bisphenol A and phthalates are additives that can cause hormone-related developmental problems. When combusted, PVC can release highly toxic and deadly chemicals such as CO, hydrogen chloride, chlorine, and benzene.

*On a yearly basis, of all the manufactured plastics, only **9 percent is recycled** and around **19 percent is incinerated**. The rest of the plastic content ends up in landfills or is left to break down in the environment. Some plastics are so cheap to manufacture that the recycling process needs to be extremely efficient to be feasible. One example is virgin PVC. Made up of salt and oil, it is very cheap to manufacture, and PVC waste is very hard to separate for recycling due to the number of mixed-in additives and other plastics. Without any incentives, this causes a constant PVC waste build-up. Virgin plastic cost is linked to the price of oil and it fluctuates. When oil prices fall recycling becomes less cost-effective and less likely. It is always best to check the commitment of a company to utilizing recycled content. When recycling is not financially justified, it is also possible to **incinerate plastic waste and recover energy**. This method is widely incorporated throughout the European Union*

Vid.11/02 Video on waste management in Las Vegas.



Fig.11/04 Plastics in nature break down into increasingly smaller pieces known as microplastics, bioaccumulative and difficult to clean.

countries, however, burning plastics produces a significant amount of CO₂ and some toxic gases and it may be doing as much harm as it is creating benefit.

The visual and performance characteristics of recycled resin can be different from virgin resin due to cross-contamination, with regard to existing pigments, plasticizers, and extenders, as well as other resins, being present, and the extent of degradation sustained by the recycled content. In 1980s, the *Society of the Plastics Industry, SPI*, created the **resin identification coding (RIC)** system, to facilitate the recycling process by assigning numbers to various resins. RIC simplifies the waste separation process, however, the consumers often think that any plastic carrying the mark is infinitely recyclable, which is not true. This can create a carefree attitude, highly detrimental to the environment. Another challenge is the resin code #7, which is named “other”. Many common and very recy-

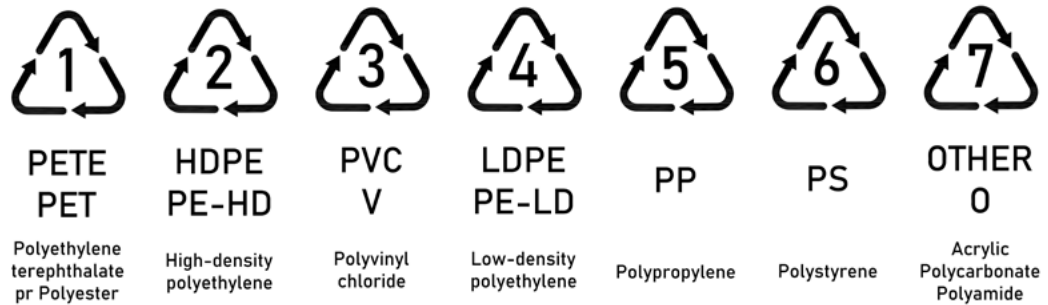

Fig.11/05 The plastic types included in the resin identification coding (RIC) system simplify waste separation, to an extent.

clable plastics such as nylon, acrylic, and polycarbonate fall under this category and they are often impossible to separate based on the identification code, unless they are clearly marked with resin name. For other plastics, resin code does not help much. For instance, resin code #3 for PVC does not get close to covering the number of variations in the available resin.

PLASTIC TYPES

Plastics can be grouped under two overarching categories: thermoplastics and thermosets. **Thermoplastics** become soft and viscous as they are heated, and when left to cool they harden back. This process can be repeated infinite times enabling the plastic to be processed and reprocessed. This category includes some widely known plastics such as nylon, acrylic, polycarbonate, polypropylene, and PVC. The general characteristics of thermosets include high impact resistance, high moldability, and most importantly recyclability. On the other hand, **thermosets** are permanently hardened, through a one-way chemical reaction that generates cross-linked chains throughout the material, and cannot be softened with heat. Some known examples are rubber, silicone, polyurethane, and formaldehyde resins. Thermosets cannot be recycled, though they can be shredded and used as a filler in other plastic

products or they can be incinerated. **Elastomer** refers to a category of plastics that can stretch and deform when a load is applied and return to its original form when the load is removed; they can be thermoset or thermoplastic. Most elastomers are thermosets such as polyurethane foam or rubber tires, there are some thermoplastic elastomer examples that can be repeatedly heat processed and recycled. Thermoplastic polyurethane is one example with a wide range of uses. **Bioplastics** are resins that are derived from renewable biomass such as maize, sugar cane, potato starch. The more popular and feasible examples include Cellulose Acetate, Starch



Fig.11/06 Thermoplastic Polyurethane (TPU) drape, TPU is the thermoplastic version of the widely employed thermoset plastic polyurethane (PU).

Plastic, and Polylactic Acid (PLA). Characterized as highly biodegradable, these methods reduce the environmental impact associated with drilling, mining, and refining processes. Even though the end-of-life impact for bioplastics is lower, extensive farming is incentivized which might ultimately result in deforestation, agrochemical use, extensive irrigation and drained aquifers, genetically modified products, and diverting food resources to industrial procedures.

THERMOPLASTICS

ACRYLIC (PMMA) • *Polymethyl methacrylate (PMMA), the plastic widely recognized as acrylic, is a thermoplastic with great optic clarity, it is lightweight, strong, chemical-, weather-, and UV- resistant.* Acrylic is often referred to with common trademarks such as Plexiglas, Lexon, and Lucite. As a transparent plastic with almost 92% light transmission, and the ability to maintain optical quality despite the increased thickness, it is superior to all other plastics as well as glass, except for surface durability. Available in a vast range of colors and transparency/translucency levels; fluorescent versions are also available for enhanced edge glow. It is possible to process acrylic panels with woodworking tools; CNC machining is another possibility. Adhesives need to be carefully picked when joining acrylic panels; silicone-, epoxy-, and acrylic-based adhesives are the most appropriate as they don't damage the material. Acrylic's hardness allows for polishing and coating, but it is also highly prone to scratches. It can be buffed and polished repeatedly; the surface can also be treated for scratch resistance. Acrylic should not be cleaned with ammonia and other glass cleaning chemicals, as they cause yellowing; only the manufacturer's recommended cleaning products should be used. Polycarbonate (PC) has higher impact strength but slightly lower optic clarity. Glass has better surface reflections, harder to scratch, and looks more high-end. Acrylic is brittle and when



Fig.11/07 Acrylic retains optical quality despite increased thickness. It is commonly used in giant aquarium displays holding thousands of tonnes of water.

it breaks large blunt splinters are formed. *Acrylic can be laminated with film to introduce tint or translucency, or layered effects.* Companies such as Lumicor® suspend different materials and objects such as leaves, straws, textiles in acrylic resin to create cast panels with various visual effects. Miss Blanche Chair by Shiro Kurumata features this aesthetic. It is also possible to suspend LED, products manufactured by Sensitile are one example. It is also possible to edge-light laser-etched acrylic pieces for interesting effects. Good melt flow, low shrinkage, and good dimensional stability render acrylic highly processible and appropriate for molded complex 3d forms where glass fails due to high post-mold shrinkage.

POLYCARBONATE (PC) • *Polycarbonate (PC) is categorized as an engineering thermoplastic owing to its high strength, optic clarity, and predictability.* It is six times lighter for the same volume compared to mineral glass, which helps reduce weight in transportation applications. It can also be used to create safety goggles, break-resistant

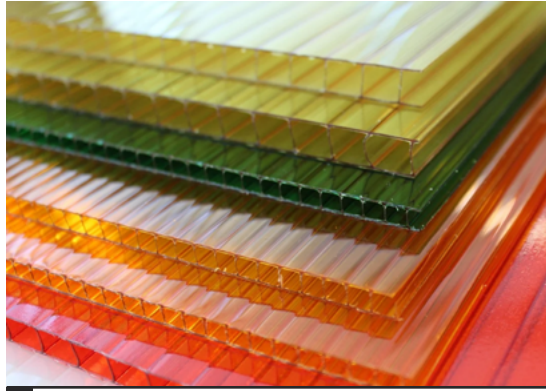

Fig.11/08 Twinwall polycarbonate (PC) panels are durable and lightweight, commonly used in skylights.

glass, and skylight covers. It can be laminated with other types of glass to create security glass. With glass fillers, PC can achieve even higher tensile strength. Acrylic has similar optic clarity and high light transmission properties, however, performs poorly in terms of impact strength and dimensional stability, PC is 1/3 more expensive than Acrylic. The biggest problem with PC manufacturing is that *it is manufactured by polymerizing Bisphenol A (BPA) with carbonyl chloride, which is often not completely polymerized and can leach into liquids.* The surface of PC is not durable which contributes to BPA contamination through further abrasion. Recycling is somewhat difficult due to the fact that both acrylic (PMMA) and polycarbonate (PC) are assigned to the resin identification code #7, making it very hard to separate them from waste streams.

POLYOLEFIN • *Polyolefin* is a family of commodity polymers, including polyethylene (PE) and polypropylene (PP), and they are very common and

via.11/03 Video on polycarbonate vs. acrylic.



Fig.11/09 Thanks to their flexibility, PEX pipes can be run like electrical conduits, without elbow joints.

versatile plastics with a wide range of uses as sheet materials, fibers, and furniture. A wide range of bright colors and good quality finishes can be achieved from glossy to matte. These are hydrophobic polymers that can prevent staining in carpets, however, they retain and build electrostatic energy. They are viable alternatives to the very commonly used nylon fibers, more recyclable but display lesser performance. This polymer family is almost totally inert, meaning they have minimal toxicity and are widely used in food packaging. **Polypropylene (PP)** is a very low-density all-purpose plastic with balanced thermal, physical, and chemical performance. Widely used in packaging. **Polyethylene (PE)** is a thermoplastic but can be transformed into a thermoset via chemically building cross-link bonds. **Cross-link PE**, also known as PEX or XLPE, is commonly used for contemporary plumbing applications. The material is low-cost, impact and cracking resistant, hydrophobic, non-toxic, flexible, and feature very high on-site workability. There are highly convenient cutting tools and connectors available and thanks to the material's flexibility, plumbing can be run behind wall panels in a way similar to electrical conduits, which in turn minimizes demolition. PE has been slowly replacing PVC for some resilient flooring applications. **High-density polyeth-**

ylene (HDPE) has high tensile strength, though not as high as acrylic and nowhere near polycarbonate. HDPE sheets can be used in construction as a machinable and thermoformable panel product; it is also used as plumbing material. Tyvek is an HDPE film manufactured by DuPont, used for weather protection during construction (housewrap), insulation aid, as well as industrial packaging.

Polyolefin polymers can be a very suitable matrices for glass fiber (GF) composites, commonly used in furniture manufacturing. Verner Panton's S chair is one example of GF reinforced PE, and a modern version is available that is manufactured from PP. There's also a more expensive polyurethane (PU) version available. GF reinforcing negatively impacts finish quality, especially in darker colors.

The polyolefin family is highly recyclable with associated resin codes such as #2 for HDPE, #4 for LDPE, #5 for PP. When used as singular plastic, for instance in packaging, they are even more recyclable, but recycling ratios are still lower than most metals.

POLYVINYL CHLORIDE (PVC) • Thanks to a wide range of modifications that can be attained with additives, **Polyvinyl Chloride (PVC)** is a *highly versatile and popular thermoplastic*. It is extremely cheap to manufacture, vastly cheaper than comparable wood and metal-based alternatives. In industrial products PVC can attain desirable tactile and visual qualities, its transparency and glossiness levels can be tailored, and big range of vibrant colors can be attained. PVC is a good thermal and electrical insulator. With the correct additives, PVC can have a very long useful life, measured in decades. Over time white PVC can yellow with UV exposure, which can be prevented through the use of additives. On the other hand, this can also be a useful property. For instance on smoke detectors yellowing indicates aging and a need for replacement. PVC products are low maintenance, highly reliable, predictable,



Fig.11/10 Without stabilizers, PVC yellows over time. A useful quality to indicate component age.

and workable, especially on site. PVC can be expanded into foam for insulation or sheet products can be used as wood panel replacement for casework, signage, partitions, etc. 70% of manufactured PVC is used by the construction industry as building infrastructure and fittings, making up 75% of combined plastic use in constructions.

Vinyl flooring is a very durable product with *high staining, scuffing, denting, and tearing resistance*. It is relatively low cost and the most popular among all resilient flooring materials. There are many product variations with names such as SVT – Solid Vinyl Tile; VCT – Vinyl Composition Tile; VET – Vinyl Enhanced Tile; LVT – Luxury Vinyl Tile. Usually when there is a “V” in product name it suggests the product is some PVC variant. Vinyl flooring is available as planks of 4” to 12” wide and 36” to 48” wide, exact dimensions vary by manufacturer; it is also available as continuous sheets of 6’ to 12’ wide, similar to broadloom carpet. Vinyl flooring has a very thin profile and when discarded, its landfill contribution is limited. *It is possible to weld vinyl at seams and use flash coving at wall bases to create a continuous flooring installation for excellent impermeability and cleanability.* This is a very popular application detail in healthcare facilities where hygiene is a significant concern and floors need to be constantly cleaned. *There*



Fig.11/11 Vinyl flooring application in an operation room corridor, the welded seams and flash coving at the perimeter are compatible with the strict hygiene require-

are two seaming methods, one involving **fusing two sheets** of vinyl together via a solvent, and the other involving **melting a vinyl rod** into the seams, a time-consuming and expensive operation though the result is a better seal. Unlike sheet vinyl flooring, vinyl tiles cannot be seamed.

Vinyl composite tile (VCT) features mineral-based aggregate filler within a vinyl matrix. It has a simple constitution, a single consistent material throughout the depth of the product. It can be fairly brittle, and has low abrasion and tear resistance. The color and pattern options are limited. Its lower upfront cost may be enticing at first, however, the maintenance requirements and the constant buffing and polishing costs add up in the long term. Another vinyl product, on the other hand, the **luxury vinyl tile (LVT)** is a slightly more expensive product with features such as a decorative printed layer and a dura-



Fig.11/12 Vinyl flooring is available in a large selection of colors.

ble wear layer. The decorative layer can mimic natural products such as leather, cork, or solid wood. Custom patterns can also be ordered. A transparent or translucent wear layer is featured above the decorative layer determining the abrasion resistance capabilities of the product. A PVC layer between the decorative layer and a backing layer below provide increased resiliency. The make-up of the tile depends on the manufacturer and it can be highly complex with many more layers. *Vinyl flooring is graded in accordance with the standard ASTM F1303, based on the **expected traffic load**, Grade 1 is*



vid.11/04 Video on heat welding vinyl flooring seams.

suitable for high traffic load commercial environments to Grade 3 for light traffic load residential environments.

Vinyl is also used in textiles and apparel. A common example is faux leather. PVC coated fabric can be embossed and finished to mimic the look of leather, though the shiny specular quality cannot exactly match real leather, creating a plasticky impression. Furthermore, it has a hot and sticky feeling as it is not breathable; tends to quickly crack and delaminate. Polyurethane (PU) is a better option for imitation leather though it is several times more expensive.

Compared to other plastics PVC has low embodied energy. Nevertheless, the overall negative environmental impact is substantial. PVC manufacturing produces large amounts of chlorine, which is a highly toxic and persistent chemical. Some of the additives such as phthalates as well as unpolymerized chemical intermediaries can be released to the surrounding environment over time, creating significant health risks for the occupants, especially developing children. *From 1954 until 1980 asbestos was used as a binder in Vinyl Asbestos Tiles (VAT). These tiles are still present in many old constructions and require vigilance and specialized services to safely remove them.* Another big health issue with PVC is its burning characteristics. It is

Vid.11/05 Video on the vinyl waste separation and recycling process.



self-extinguishing when exposed to a small fire, however, when combusted PVC emits carbon monoxide, hydrogen chloride, and benzene which are serious irritants with high toxicity. Even though PVC is recyclable with its separate resin identification code, #3, due to a large range of modified versions in the market, separating is very hard, and recycling is not justified as virgin material is very cheap. PVC is praised for its durability; however, it does not biodegrade or break down which makes it somewhat of an environmental menace.

While not classified as a polymer, linoleum is the predecessor of the modern vinyl flooring and there are many overlapping features. **Linoleum** is manufactured by oxidizing linseed oil, or flax oil, and developing a composite mixture with wood and cork flour as well as various natural resins and pigments. The material is porous due to wood and cork filler content, requires yearly sealing. It is insulative and feels warm. It is non-toxic and fire-resistive, anti-static, repels dust and dirt. Seams can be joined by melted



Fig.11/13 Luxury vinyl tile (LVT) can imitate any material thanks to a printable layer.



Fig.11/14 Linoleum is capable of complimenting any contemporary environment.

linoleum rod or latex adhesives, which improves the hygiene factor. UV light exposure causes yellowing. Linoleum has relatively low abrasion resistance. It can show scuff marks, however, it can also self-heal very small dents over time. It can be buffed and refinished. Linoleum is a natural product and it is completely biodegradable. It can also be composted, yet this makes it susceptible to mold and mildew growth. Linoleum is susceptible to staining and yellowing when in extended contact with alkaline liquids and cleaning products.

POLYSTYRENE (PS) • *Polystyrene (PS)* is a fairly cheap plastic with low melting point rendering it highly suitable for low-value, disposable items. It can be utilized either as foam or in rigid form. Commonly used for disposable tableware and protective, insulative, and disposable packaging components. High impact polystyrene is used in models and toys, and as sheet material in construction. ***Expanded polystyrene (EPS)*** is a very lightweight product with trapped air consisting 95% of its volume, known by the trademark *Styrofoam*. Used extensively in construction as insulation, molds for decorative spatial elements, or as the decorative elements themselves. There's another version known as ***Extruded Polystyrene (XPS)***, which has higher density and strength, with higher R-value and



Fig.11/15 The pink colored extruded polystyrene (XPS) is a common insulation material.

rigidity. A better insulation material though relatively more expensive. Both materials can be shaped with computer-controlled hot-wire cutters and can be used for temporary spatial elements for exhibitions or events, or in model-making. There's an additional PS type named graphite polystyrene (GPS), with an even higher R-value, providing better insulative properties. PS is an extremely prevalent plastic. Even though polystyrene has its own resin identification code, #6, it is not feasible to recycle. The waste PS is often mixed and contaminated with other trash and difficult to separate. Due to its low weight and high volume, it is not economical to transport to a central recycling plant. PS is highly degradable under UV light and when exposed to chemicals, very susceptible to breaking down into micro-plastics.

When combusted polystyrene (PS) produces significant amounts of soot, a dense cloud of impure carbon particles which pose health risks, therefore not very suitable for incineration either.

POLYAMIDE (PA) • *Polyamide (PA)* is a high-performance thermoplastic with great wear resistance and flexibility. It is extensively used in commercial fiber applications; rigid molded applications are also available such as part enclosures, tool handles, and medical implants as it can perform as a reasonable replacement for metal parts. A very common version of PA is known by the trademark *Nylon*, which has several versions in itself, 6 or 6.6 being most popular – these numbers are simply referring to the number of carbon atoms in its monomer form. Typically, polyamides contain hydrophilic amide groups, if untreated they can absorb water and moisture, swell, and stain. Nylon 6.6 exhibits a lower absorption rate, better chemical resistance, better flexibility, however, it is also relatively difficult to mold,

color, and finish. Nylon is commonly blended with wool for increased strength. Aromatic Polyamides, known also as “aramids” are extremely durable and fire-resistant synthetic fibers, widely known by the trademarks Kevlar and Nomex. PA’s resin identification code is #7, shared with many other plastics. Consequently, it is hard to separate and recycle. Separation is even harder for PA blended with other fibers for textile manufacturing or woven into other materials.

*Nylon is a **highly durable** material. This creates a significant negative environmental impact. For example, it is widely being used for manufacturing fishing nets and due to the very slow decay rate, an estimated 10% of debris in the ocean is discarded nylon.*

POLYESTER (PET) • Polyester or **polyethylene terephthalate (PET)**, is a relatively inexpensive and versatile plastic with balanced properties, commonly used for food and drink packaging. It is relatively non-toxic, free of bisphenol A (BPA), phthalates, and dioxins, resistant to many chemicals. It is inert and does not interact with alcohol, fat, oil, etc. However, when exposed to heat it becomes unstable and can start leaching anti-



Fig.11/16 The highly durable Nylon fishing nets are a significant source of pollution for the oceans.



Fig.11/17 Fiberglass reinforced polyester resin is being applied to a mold.

mony. Thanks to its high elasticity, impact resistance, and lightweight, high-quality thin-walled containers can be blow molded easily, making PET extremely widespread in disposable bottle manufacturing. Polyester fiber is commonly used in textile manufacturing, primarily in the apparel industry. PET is also highly suitable for medium to low traffic carpeting applications; Nylon is a better option for high traffic situations. PET bottles are commonly recycled to carpet fibers, *Polyester is a commonly used matrix for **glass fiber reinforced plastics (GFRP)***. This material was widely experimented with by Charles and Ray Eames, who designed a number of molded furniture with this material in mind. There were some toxicity issues with earlier versions. Current versions mainly utilize polypropylene. Commonly used drafting medium Mylar® is also PET. The resin identification code for PET is #1,

vid.11/06 Video on testing polyester security film on glass.



it is one of the most commonly recycled plastics. It is very easy to recognize and separate from waste streams, therefore easier to recycle and the resulting recycled plastic is of high quality. It is not uncommon to see trashcans dedicated to PET bottle disposal.

THERMOSETS

RUBBER • *Rubber*, or *polyisoprene*, is a thermoset polymer known for its elasticity and high resistance against chemical agents, heat, and abrasion. There are two overarching types of rubber available: natural and synthetic. Natural rubber is tapped from the rubber plant grown in tropical regions, and synthetic rubber is synthesized from petroleum byproducts. Natural rubber features high tear resistance, tensile strength, and a relatively low melting point. On the other hand, synthetic rubber has excellent heat and chemical resistance. The properties of both rubber types are unique and they are often blended; the level of flexibility, as well as the performance properties, can be specifically tailored for the

purpose of the end product, rendering rubber highly versatile. **Vulcanization**, also referred to as *mediated crosslinking*, is a curing process for enhancing a thermoset polymer's properties. The term is mainly used to refer to the process of treating rubber with sulfur after the resin is shaped. The cross-linking processes for silicone and polyurethane are also referred to as vulcanization. The process enhances the plastic's ability to revert back to its original form after sustaining significant deformation.

Rubber flooring is very durable and resistant against deformation and indentation, provides significant slip resistance, suitable for places that feature a lot of heavy traffic, especially rolling loads. Rubber flooring is also light on joints and mitigates occupant fatigue to an extent. Highly comfortable underfoot, rubber flooring is used in gyms, playgrounds, and in workplaces where employees spend hours standing. Initial costs may be relatively higher, however, the material is very resilient and its useful life is fairly long.

60% of all rubber production goes to tire manu-



Fig.11/18 Rubber flooring is highly suitable for gym environments, where heavy loads are dropped and rolled around continuously.

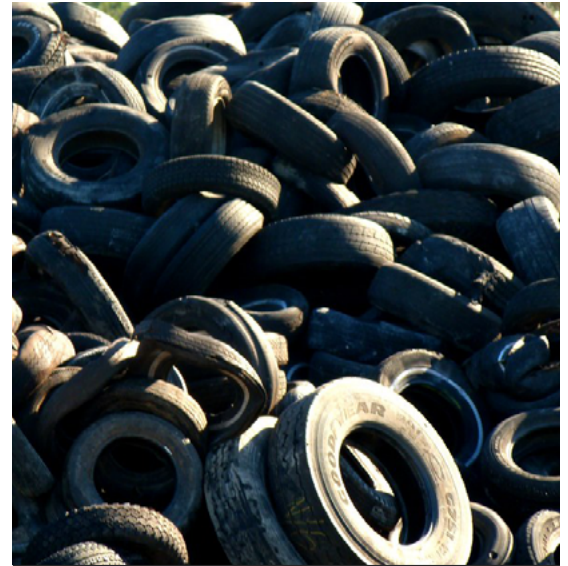

Fig.11/19 Used tires are not wanted in landfills as they can trap methane because of their shape.

vid.11/07 Video on contemporary rubber recycling process.



facturing. Tires are discarded after a relatively short useful life, creating a significant source of waste. As a thermoset plastic, rubber is very difficult to recycle into useful virgin material. There are two alternative paths of recycling available. The first method is **devulcanization**, which is a chemical and thermomechanical process to reverse the effects of vulcanization and partly replace the virgin material. There are various methods still in development to increase the feasibility and quality of this option. The other recycling, or rather reusing, method is grinding rubber and using it as feedstock or filler in other products. There are many examples of high-end flooring finishes and carpet paddings utilizing this particular technique.

POLYURETHANE (PU) • Polyurethane (PU) is one of the most popular polymers, available in two subtypes: thermoset (PU) subtype primarily as open-cell flexible foams and thermoplastic (TPU) subtype as rigid molded forms; the thermoset subtype is not melt-processible. **Polyurethane** has great shape-retention and minimal creep. Even after receiving heavy loads for extended periods, it returns back to its original shape easily. Its performance and properties can be fine-tuned via various additives. 1/3 of all polyurethane manufactured is flexible foam, mainly for upholstery use and highly efficient insulation. Polyurethane foam is manufactured as giant slabs in varying densities and hardness, commonly referred to as slabstock; these are then cut to the desired shape. **Memory foam**, also referred to as viscoelastic polyurethane, is a very popular padding commonly associated with comfort. The foam reacts to body heat and becomes softer, better accommodating the user.

However, the price point of the material is relatively high and is rendered useless in very high or low temperature environments. Polyurethane has a wide spectrum of use beyond foam, can be molded as solid objects, flexible objects; can be used as core for sandwich panels, or can be manufactured into high-performance coatings, adhesives, or sealants. Thanks to its elastic nature, the fiber form can be woven, into stretchable garments. **Polyurethane in thermoset form cannot be recycled**, however, it can be ground and used as filler for other products, such as carpet underlays. Incinerating polyurethane is another option, however, this produces toxic gases such as carbon monoxide and hydrogen cyanide.

EPOXY • **Epoxy**, also known as polyepoxide, is a highly versatile thermoset plastic. Epoxy by itself has limited mechanical performance, and in order to achieve the high-performance it is widely known for, it needs to be mixed with a curing agent referred to as the **hardener**, enabling dense cross-links to form throughout,



Fig.11/20 Polyurethane spray-foam insulation is highly efficient but requires flawless installation to properly function.



Fig.11/21 Epoxy flooring is actually a thin resin layer and requires meticulous substrate preparation.

allowing the material to gain strength and rigidity. Different types of hardeners can be utilized for different purposes or to adjust curing times, also known as pot-life. After curing, the material gains superior resistance to chemical, thermal, and physical abuse. Epoxy is commonly known as a flooring finish, but it is also used for grouting, as an adhesive, a surface finish, and it is highly popular in DIY furniture design, among many other uses.

Before the application, the substrate needs to be carefully sanded, vacuumed, and washed. Epoxy is applied as layers of very thin film and it telegraphs any irregularity on the substrate. The leftover sand and dust particles can contaminate the film. This process needs to be carefully controlled and requires specialization. If the mix-ratio is not correct, there's a possibility of uncured resin or hardener being left out, deteriorating material performance. The curing process is exothermic, meaning it will release

via.11/08 Video on decorative epoxy installation.



heat, however, since interior applications are thin films, the heat build-up does not cause problems. During curing epoxy releases VOCs, which can quickly build up in confined areas. A mask/respirator with a vapor/gas cartridge needs to be used for safety. Proper ventilation is necessary to control VOC buildup and for letting the excess heat escape. Uncured epoxy should never be sanded due to high toxicity. After curing the material is inert.

The key ingredients in most epoxy are epichlorohydrin (ECH) and bisphenol-A (BPA), though alternative formulations are available. Around 2% of the population tends to develop some form of allergic reaction and discomfort when exposed to epoxy. *Even though there are methods in development, currently, epoxy is **not recyclable**.* Epoxy waste should not be mixed with household waste.

Uncured epoxy is toxic. Unused material should be left to cure and taken to a local waste management center.

FORMALDEHYDE • Formaldehyde is one of the oldest synthesized plastic resins, known since 1855. It is brittle after it is cured, and displays somewhat poor moldability features, however, performs well as a resin matrix for panel products and objects with simplistic forms. Formaldehyde is also found in various adhesives, sealants, laminates, insulation, and coating products. There are three widely used versions, melamine-, phenolic-, and urea-formaldehyde each with slightly different properties. Phenol-formaldehyde resists moisture, is stable, and has better strength. Oriented strand board (OSB), and some plywood panels employ phenol-formaldehyde. On the other hand, the widely used urea-formaldehyde is cheaper. Urea-formaldehyde is commonly used for particleboards, MDFs, and some plywood panels. There is also melamine-formaldehyde, used in laminate manufacturing. Clarity of the



Fig.11/22 The transparency of melamine-formaldehyde resin enables a vivid representation of pigments.

resin enables vivid colors and accurate rendering of decorative layers.

Formaldehydes, especially urea-formaldehyde, are known to be substantial sources of VOCs. Phenol- and melamine-formaldehyde emits, comparatively less dangerous VOCs. Since they are still widespread in the market, the designer should pay attention if the materials being specified contain formaldehyde and what the emission levels are. It is best practice to seal the material properly. For instance, laminating a particle board panel, or applying urethane coating on an OSB panel minimizes VOC emissions as long as the sealing layer is intact and doesn't sustain damage. Another important precaution is the pre-occupancy ventilation period of the environment to disperse VOCs released during the initial, more dense emission periods.

*The designer should make sure that the **temperature and humidity** of the application environment stay balanced, as an increase in these parameters exacerbates VOC emission levels.*

SILICONE • Silicone, or polysiloxane, is unique among the popular polymers. Its building block is an inorganic monomer made up of silica and

oxygen; however, it is still widely regarded as a plastic. Silicone is anti-microbial and hypoallergenic, highly durable, water-resistant, and chemically inert with no known toxicity. It is often used for heat-resistant cookware, it is flexible with great tear and scuff resistance. Silicone is commonly used for manufacturing adhesives and sealants in the construction industry, highly compatible with most materials. Like other thermosets, it is difficult to recycle, can only be downcycled in the form of silicone oil or shredded and used as filler.

MANUFACTURING METHODS

Plastics are ubiquitous in the modern world. For a designer, a fundamental knowledge of plastic manufacturing methods is exceedingly helpful, not only for designing custom components involving plastics but also when specifying plastic products. All thermoplastic manufacturing processes involve heated resin shaped to a mold, such as thermoforming, vacuum forming, drape-forming, injection molding, blow molding, rotational molding. Thermosets are cured through a chemical reaction after they are introduced to a mold. The appropriate manufacturing method depends on the shape, structure, and complexity of the product, output volume, and the type of plastic to be used.

Thermoforming is essentially forming with heat. Thermoplastics in sheet form heated to a temperature at which they become soft and pliable but not melted, then formed into the desired shape by use of a mold. In **drape forming** heated plastic is draped on a piece of mold. In **vacuum forming** sheet plastic is heated and placed over a mold, then by sucking out the air, the plastic piece is forced to tightly envelope the mold, taking its shape. Edge trimming is required for most of these applications. The degree of surface detail that can be attained with thermoforming is fairly limited. Sheet plastics can also be processed like paper: creased, folded, and

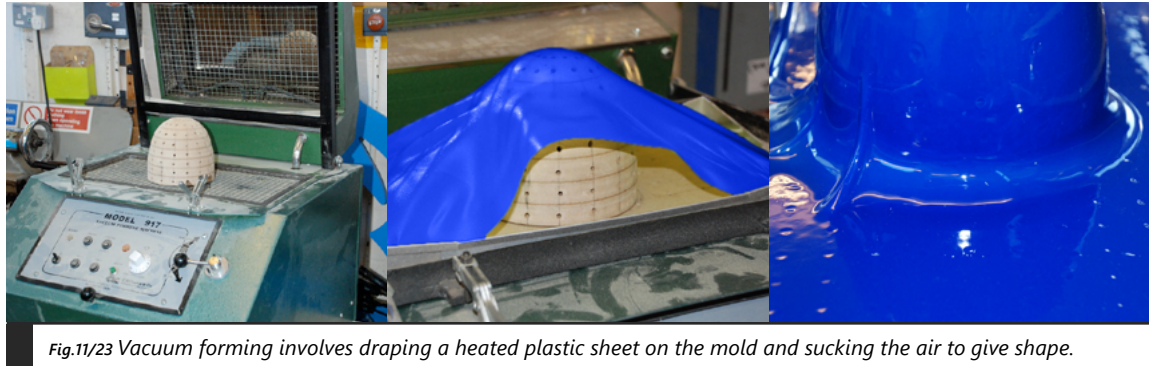

Fig.11/23 Vacuum forming involves draping a heated plastic sheet on the mold and sucking the air to give shape.

cut. Such techniques are widely employed in packaging.

Extrusion is when melted plastic resin is forced through a shaped opening to achieve a continuous profile. Pipes, tubing, railing, sheet films, as well as some complex profiles such as window framing can be manufactured with extrusion. It is possible to directly form an extruded jacket around a wire. Thin sheets of acrylic and polycarbonate are extruded, thicker panels are molded. Calendering is a method similar to extrusion, it is used to produce plastic sheets and films by

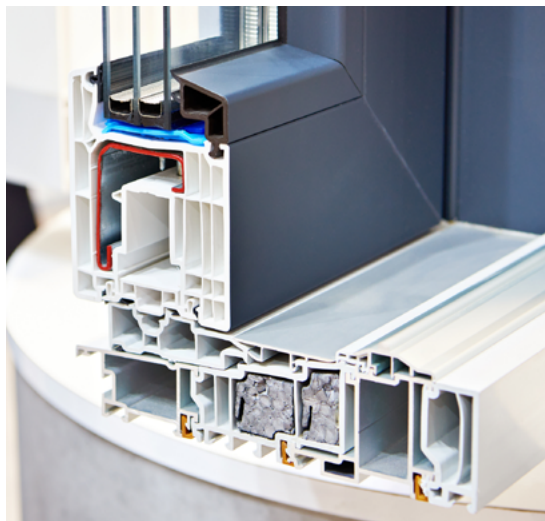

Fig.11/24 The highly complex PVC window profiles are one example for thermoplastic extrusion.

forcing the resin between two heated rollers; commonly used in non-woven textile manufacturing.

Injection molding involves forcing melted plastic pellets into a mold at high pressures. A common method for molding three-dimensional products with complex surface details. This method gives the designer a lot of control, it is possible to adjust the wall thickness, and attain strength where needed, significantly saving manufacturing costs. Depending on the resin type, mold complexity, size of the cavity, and expected output, mold design and tooling can be very expensive. *It is justified only when a very high volume of production is expected.* Injection molding has very short cycle times and a very high output volume. Each year 60 billion LEGO pieces are manufactured with this method. The success of the final product depends on mold design as well as resin selection. Injection molding requires high melt flow and not appropriate for all types of plastics due to the possibility of defects. HDPE, Polyolefins, Acrylic, and Nylon are excellent for molding, whereas PVC, silicon, and rubber may require various additives for

vid.11/09 Video on the intricacies of injection molding.





Fig.11/25 A retired Lego injection mold.

successful implementation. Furthermore, different types of plastic have different dimensional tolerances, and the output of the same mold can have different dimensions for different plastics. After molding, injection hole artifacts and resin flash are visible and must be sanded and removed. *It is possible to inject multiple resins from different injection units into multiple molds in close sequence with **multishot injection molding***; different colors, surface qualities, and performance properties can be obtained on the same product. **Overmolding** involves securing a previously manufactured plastic or metal component inside the mold, then injecting resin to cover part or entirety of the secured object, bonding both components. Useful for creating a rigid internal support, embedding electronics, etc.

Unlike injection molding where melted resin is injected into a cavity at high pressure; *in **compression molding**, pre-heated resin is placed into a heated mold, which is then closed and compressed*. Appropriate for thicker parts with fewer details, mold costs are relatively lower, on the other hand, cycle times are slower, output is low, and cost per piece is higher. Appropriate when low to medium output volume is required.

Similar to mold-blown glass, *in **blow molding** air is blown into heated plastic, inflating it into the mold's shape*; bottles and containers with consistent thin walls or multiple layers are

Vid.11/10 Video on the blow molding process.

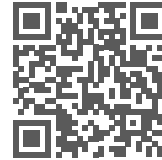

produced with this method. It is possible to utilize multiple molding techniques on the same plastic body, permitting some complex form-making. Some blow molded items start out as extrusions. It is possible to injection mold some details like complex handles or spouts with precise details and then blow mold the rest of the object.

Rotation molding involves continuously rotating molds while heating powdered resin inside, essentially coating the surfaces with approximately equal thickness plastic. It is possible to mold large objects that are completely sealed as well as with open ends, while achieving a constant wall thickness throughout. This method has low output volume. Large buoyant objects, inflatables, liquid containers, as well as sizable furniture pieces can be created with rotation molding, one famous piece being Marc Newson's Plastic Orgone Chair.



Fig.11/26 In blow molding, the PET billet is heated, and after they are placed within the mold air is pushed in to expand the object into the shape of the mold.



Fig.11/27 In this rotation molding example an open flame heat source is utilized.

Dip Molding involves dipping a mold into melted plastic such as PVC or polypropylene (PP), covering the mold with a consistent thin layer of plastic with an open end. It is possible to dip-mold woven backing, which is commonly used in textile and apparel manufacturing.

Sometimes referred to as “growing” a product, **3d printing** is an additive manufacturing process where the material is deposited in sequential layers to achieve the final form. There are many types available, such as laser sintering and fused deposition or fused filament printing. It is great for prototyping and very low volume manufacturing. Various methods can provide down to 10 microns precision, enabling some highly intricate details to be achieved only with 3D printing. However, these high-precision techniques such as laser sintering and stereolithography can be very expensive, furthermore, the part might not have the same mechanical performance as a conventionally manufactured alternative. With the advent of low-cost 3d-printers directed towards enthusiasts, a potential health hazard became more apparent. *During the printing operation, the melted and deposited plastic material releases toxic fumes.* A National Institute for Occupational Safety and Health (NIOSH) study claims the emissions from

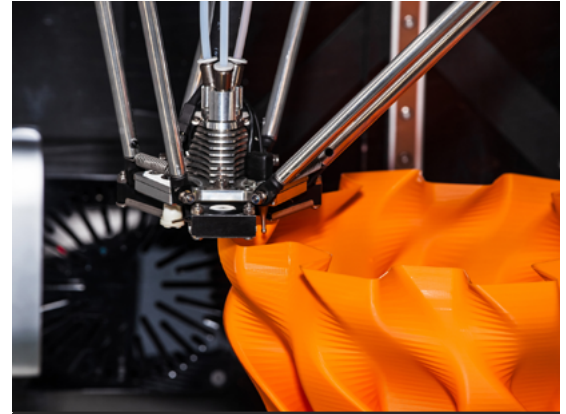

Fig.11/28 3d printing is great for prototyping. The performance of the fabricated object is relatively low.

heated ABS and PC feedstock as damaging to lung tissue.

Plastic Welding involves applying a heated thermoplastic or curable plastic to a seam between two plastic pieces for the purpose of joining the two. The strength of the bond is dependent on the compatibility of joined plastics and the welding plastic. This method is very common in vinyl flooring applications, enables seams to be flush and non-permeable which is helpful for cleanability. It is also possible to join plastics by applying chemicals or heat to the seam.

COMPOSITES

In materials science, the term **composite** refers to the combination of two or more materials in such a way as to create a new material with enhanced properties. Composite materials offer excellent strength-to-weight, dimensional stability, increased useful life, and added functionalities such as thermal or electric insulation, etc. Composites have been used throughout history. Mudbricks, being one of the earliest examples, involved a combination of straws and mud to enhance the resistance of bricks against tensile forces while minimizing crumbling. The same fundamental principle is seen in the rein-

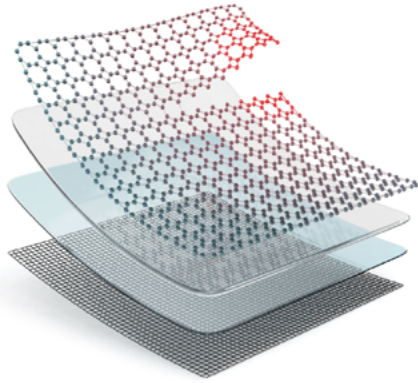

Fig.11/29 A composite material constitutes multiple materials that enhance each other's performance.

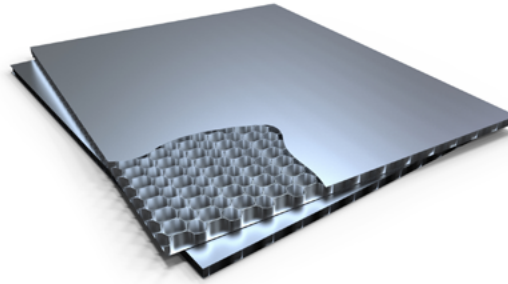

Fig.11/30 Sandwich panels typically feature a core layer sandwiched between protective sheets.

forced concrete today. The aggregate in cement matrix creates a stronger composite material by resisting compressive forces, however, this is taken one step further with the addition of a steel rebar reinforcement, creating a very strong construction material that can resist tensile stress as well. Another significant example is fiberglass. Developed in the late 1930s, fiberglass is composed of thin strands of glass, woven into fabric and then fused with a resin or plastic. Composites can even occur naturally. Wood is classified as polymer composite, where the cellulose fibers are bonded by lignin.

Composite materials can be constructed in various ways. It is possible to set fibers, flakes, chunks, sheets, or meshes in a resin to create a composite. In this type of composite, *the resin is called the **matrix** and it binds the added material that is called the **reinforcement***. Essentially, the reinforcement enhances the mechanical properties of the matrix, while the matrix

holds the material's shape and determines its surface quality. For instance, carbon fiber as a reinforced composite involves woven carbon fibers set in polymer resin; it can be five times stronger than steel while having only one fifth of the mass. In bioplastic composites, fibers can be added to compensate for inherent structural weakness. *Unlike alloys, the physical and chemical properties of each separate component of the composite material are **maintained***. The naming conventions work both ways to include either the reinforcement or the matrix, such as fiber-reinforced composite, or metal matrix composite. **Sandwich panels** are also considered composite materials; they feature a core, typically lightweight or insulative sandwiched between two sheets of another material. For instance, an aluminum honeycomb panel can be sandwiched between two sheets of aluminum, creating a material that is much stronger and much lighter than an aluminum sheet of the same thickness. Another example would be glass wool insulation being sandwiched between corrugated aluminum panels. In this case, the corrugations give strength to the composite, while glass wool creates a heat barrier.

Composite materials have two significant shortcomings. *First is the long and costly **research***



Vid.11/11 Video on the history of composite materials.



Fig.11/31 Typical carbon fiber implementation involves plain woven carbon fibers set in epoxy resin matrix.

and development processes. It is exceedingly difficult to achieve a perfect combination of materials that will work in harmony without deteriorating each other's performance while improving the overall mechanical and chemical properties. It is very costly to develop and manufacture these complex materials. *Another downside is the **challenges to recycling** due to complex combinations of dissimilar materials.* Composites are often not feasible to recycle, though for some components' prohibitively excessive initial cost can incentivize the development of efficient recycling practices, one example being the very expensive carbon fiber.

INTERIOR SPECIFIC POLYMER PRODUCTS

RESILIENT FLOORING • In materials science, the term **resilient** is used to refer to materials that are strong, durable, and flexible enough to absorb impact and endure deformations, and return to their original shape following the removal of the load without experiencing creep. This group of materials are either come in sheet or panel form, typically with a thin profile, they are relatively cheap. Materials such as vinyl, rubber, linoleum



Fig.11/32 Cork is categorized as resilient flooring, though it cannot perform as well as polymers alternatives.

are considered in this category and show high resiliency. Compared to polymer-based alternatives, some natural materials in this category are less resilient such as cork or leather.

The history of resilient flooring starts with Linoleum in 1894, which was the precursor to modern resilient flooring materials. Between 1894 and 1904 various other tile floorings were introduced to the market, including rubber and cork. Vinyl composition tile wasn't introduced until 1943, though, it became increasingly popular as new variations on the material are introduced and the material became cheaper, more durable, and functional.

Today a number of material compositions are available with some variation in performance and sustainability characteristics. A **printable layer** enables any material to be imitated, or **pigments and colorful flakes** can be introduced, not only for aesthetic value but also for hiding soiling and scuffing. A strong wear layer enables the already resilient and durable materials to perform very well under heavy traffic loads. *Various seaming techniques such as hot rod melting and chemical welding with a variety*

of baseboard and threshold details enable a **consistently impermeable floor**, highly suitable for wet spaces and rigorous cleaning practices.

Building static charge is a significant problem with polymer-based flooring products, especially in spaces where flammable materials are stored or used, such as hospital operating rooms, or where electronic hardware is housed such as server rooms. For such environments, the designer should consider inherently antistatic solutions such as conductive rubber, or static dissipative tile.

SOLID SURFACE & QUARTZ • The term **solid surface** refers to a category of composite sheet products that utilize a polymer resin matrix such as acrylic, epoxy, and polyester, various fillers, and complex pigmentation that offer a wide range of colors and textures. Some examples can even accurately imitate natural stone counterparts. These products are highly workable and can be processed with widely available woodworking techniques; they can be sawn, milled, and even bent with the application of heat. Solid surfaces are typically specified for countertops, however, the application possibilities are virtually limitless due to their high workability provided by the thermoplastic matrix. Application examples include high-end complex front desks, sculpted seating units, residential countertops with integrated sinks and functionality, wall paneling with depth, and flowing ceiling elements. On the other hand, the same polymer matrix carries most disadvantages of the original polymer, for instance, an acrylic matrix will be susceptible to surface scratching, or heat can cause damage. Acrylic, epoxy, and polyester matrices are not completely chemically inert, so when a solid surface material featuring these resins is to be specified, possible chemical exposure to strong acids, chlorinated solvents, and acid drain cleaners should be considered. Longer exposure means stronger staining and harder removal. However, thanks to their homogeneous color-through constitution the material can be easily repaired and patched,



Fig.11/33 Solid surface product being bent around a plywood mold, through utilizing a mixture of heat treatment and kerfing techniques.

many times over.

Solid surfaces are available in $\frac{1}{4}$ " thickness for vertical applications, $\frac{1}{2}$ " and $\frac{3}{4}$ " for other applications. The sheet size varies between manufacturer and product, but they are typically around 30" x 144" for thicker and 30" x 98" for thinner sheets. *One great advantage of solid surfaces is, despite the limited sheet sizes, **seams can be completely hidden** with the application of heating and buffing, which enables continuous stretches.*

The National Sanitation Foundation, or currently known as NSF International, is an independent organization that publishes various health, sanitation, as well as food and water safety standards. *Part of the standard **NSF 51** outlines various resin-based countertop materials that are deemed safe for commercial food production.* The designer should check if the solid surface material is NSF 51 compliant or not, especially in



Fig.11/34 With complex pigmentation techniques quartz panels can imitate natural stone convincingly.

cases where food contact is expected.

Engineered stone, also commonly referred to as quartz, is similar to solid surface, however, around 90% of the material composition is quartz used as filler. Epoxy, polyester, or other resins are used to make up the matrix component. Quartz and quartzite are different materials. Quartz is an artificial panel product and **quartzite** is a metamorphic stone with a granular texture and impressive hardness. The hardness of quartz particles renders engineered stone highly resistant to abrasion and scuffing, equal to granites with the highest resistance. Moreover, the material does not require any sealing or other periodic maintenance. It is inherently NSF 51 compliant. Quartz is available in 2cm (3/4") and 3cm (1-1/4") thicknesses, and its workability is similar to granite, however, due to their homogeneous, or isotropic nature the possibility of breakage is much lower. One disadvantage of quartz over solid surfaces is that the seams cannot be hidden, also, cracks and other damage over time cannot be patched in a straightforward manner. Some quartz panels are marketed as heat resistant; however, **excessive heat exposure** is known to cause cracks and at the very least discoloration. Undiluted use of **acidic cleaners** can also cause discoloration over time.



Fig.11/35 Plastic laminates can feature solid colors, natural textures, as well as bespoke graphics.

PLASTIC LAMINATES • **Plastic laminates** are thin sheet products that comprise several layers of paper bonded together with formaldehyde resin, followed by a decorative layer that can feature any image, and a clear wear layer that provides protection against abrasion. Owing to the combined effect of the visual decorative and tactile top layer, any material can be imitated to an extent, such as all solid woods with high-gloss, satin, or matte texturing; granites, marbles, travertines, metals with a variety of sheen levels. Bespoke designs are also possible, services provided by almost all laminate manufacturers.

Plastic laminates are **intended to adhere to various substrates** such as particleboard, MDF, plywood, cement board. Laminates are just thin sheets of material and unless the edge is continuous, i.e. rounded/filleted, the sides of the substrate will be exposed. These exposed areas can be closed off with edge bands appropriate for specific panel thicknesses or the same plas-



vid.11/12 Video on laminate countertop application.



Fig.11/36 Plastic laminate edges and seams are prone to heat and moisture damage.

tic laminate can be applied.

Plastic laminates can be used for countertops, as long as the substrate's behavior against moisture is stable. *Plastic laminates have **size limitations**, typically matching common substrate sizes such as 4' by 8' or 6' by 12'; when there are turns, corners, or extended areas involved a seam is needed.* Typically, these seams represent weak points on the surface. The seam needs to be far away from water sources and all edges need to be sealed. In addition to moisture concerns, the designer should be concerned about heat exposure as well, as continual exposure to heat can cause plastic laminates to delaminate especially at the seams and edges.

High-pressure laminates (HPL) feature multiple layers of kraft paper, impregnated with resin consolidated via the application of high heat and pressure. Compared to standard plastic laminates they contain 3 to 4 times more layers, providing extra durability and impact resistance. Similar to standard plastic laminates, HPL's also require a stable substrate. **Compact laminates** feature a core that is completely consisting of resin-impregnated kraft papers, sandwiched between laminated sheets, via the application of intense heat and pressure. Even though slightly expensive, compact laminates are highly

durable and moisture resistant, very suitable for use in wet spaces as well as outdoors. Various compact laminates available in the market make use of colored core layers, enabling the designers to create various profile effects that work very well with CNC machined parts.

12

SPECIFICATION

- *The business and key professionals*
- *Common specification types*
- *Standardized specification content*
- *Project cost estimation*
- *Conducting field survey*
- *Criteria for successful specification*

For an interior architect or designer, design skills and technical knowledge only partly contribute to career building. The professional is also expected to build and maintain reputation, integrity, and credibility; always holding themselves to a high ethical standard. Networking, creating, and maintaining a team of professionals, including representatives, vendors, contractors, installers, as well as a number of consultants from specification writers to acoustical engineers, are also highly important.

In the context of interior architecture and design, a **contractor** is an individual or a company that coordinates and supervises a project, develops a schedule, handles permit processes, acquires materials and services, ultimately ensuring that the design intent is realized accurately and on time. Typically, the client hires the contractor, though it is possible for the design professional to hire the contractor or function as the contractor. Local laws might require licensure to perform contractor duties, for instance, the State of

Kansas requires the individual to be pre-qualified to work as the prime bidder. State laws for qualification and licensing requirements for contractors should be checked before committing to any contractor duty. The designer should understand that even though the contractor is responsible for realizing the design intent, the designer will ultimately receive the credit or the blame for the finished design product, and should be ready to assume responsibility and act accordingly.

*As long as there is healthy competition in the market, with regard to the materials specified and the contractors and installers hired, the designer almost always **gets what they pay for**.*

Contractors hire qualified professionals such as subcontractors and installers to finish various tasks required by a project and they also ensure that all teams are scheduled efficiently and working safely. **Subcontractors** are specialized professionals who are hired by contractors to perform a specific group of tasks, such as electrical, plumbing, demolition, etc. work. If the designer is the person hiring a subcontractor, beyond looking at a website or portfolio and reviewing photos of previous work, they should make sure to examine previous or ongoing work by visiting a job site as well as speak to references to assess credentials, work ethic, and quality of output. The designer should always clearly communicate expectations to the sub-contractor. **Installers** are employees performing work on site, such as assembling and installing furniture, applying paint, or laying tiles. They may be hired separately, through a



Fig.12/01 Realizing a project involves a large team of professionals coordinated by the designer.

contractor, or a sub-contractor. Whether they are directly hired by the designer or not, installers represent the designer on-site. Consequently, their attitude and manner of communication bears significance.

*In the most simplistic sense, **manufacturer representatives**, also referred to as sales representatives or “reps”, act as intermediaries for manufacturers, promoting and selling their products to professionals. Reps can represent a single product line for a company or multiple non-competing products from several companies. Representatives have extensive knowledge and experience about the materials they promote and can be a true ally to the designer.*

*Manufacturer representatives help designers by providing **product knowledge**, alerting them about discounts, provide pricing information, guidance and tips, suggest sub-contractors for processing and installing the materials as well as aiding in troubleshooting issues.*

Establishing a dialogue with manufacturer representatives is one important way to learn about and get help on material specifications. However, various other sources of information are also available to the designer. **Dealers, distributors, and vendors** offer a selection of materials, prod-

Link 12/01 Additional information on contractor pre-qualification.



ucts, and supplies as well as related services in some cases often only to professionals. On the other hand, resellers and retailers sell products directly to end-users; designers can also assume this role. *The contract for **Furniture, Fixtures & Equipment (FF&E)** is separate from the contract for construction.* It includes services pertaining to storage, delivery, assembly, and installation of the products, signed between the vendor and the client. **Showrooms** are *wholesalers who promote product lines from multiple manufacturers.* A close relationship with these businesses is important as they can be helpful in securing trade discounts and solving issues with orders. *Custom items such as window treatments, bespoke furniture, and casework are often fabricated in **workrooms**.* Since workrooms provide specialization in one aspect of interior space, their feedback and advice are often highly valuable.

The designer can request samples from a wide selection of sources, including but not limited to, manufacturer representatives, vendors, and showrooms. **Material samples** provide a relatively small section/piece of the actual material, generally around 2" by 2" to 8" by 8" in size, though the sizes vary substantially between



Fig.12/02 Showrooms enable side-by-side comparison of multiple products.



vid.12/01 Video on how workrooms function.

manufacturers and products. Samples are very helpful in assessing the exact look and feel of the material. An additional benefit is seeing the representation of the effect of various materials together. *Designers can prepare **material boards** to assess the synergy and impact of various materials in combination.* Material boards are also a great way to communicate ideas with clients as well as collaborators.

*When building a material board, the designer should pay close attention to the **visual composition**; how the negative space is employed, how the sample relationships are defined via adjacency and overlaps, and how the organization of samples represents the final product.*

An important aspect of becoming an efficient designer is understanding that interior design involves far more than the individual effort of the designer. On the contrary, it involves the totality of expertise and efforts of many professionals throughout the process. *Consequently, the successful completion of any project heavily relies on a **healthy team dynamic**.* Keeping professional relationships in good standing is crucial for ensuring project success.

SPECIFYING MATERIALS

Within the context of spatial design, *the act of **specifying** refers to determining the materials, furniture, fixtures, and equipment involved in realizing the design intent.* On the other hand, *the term **specification**, or spec, refers to a clear*

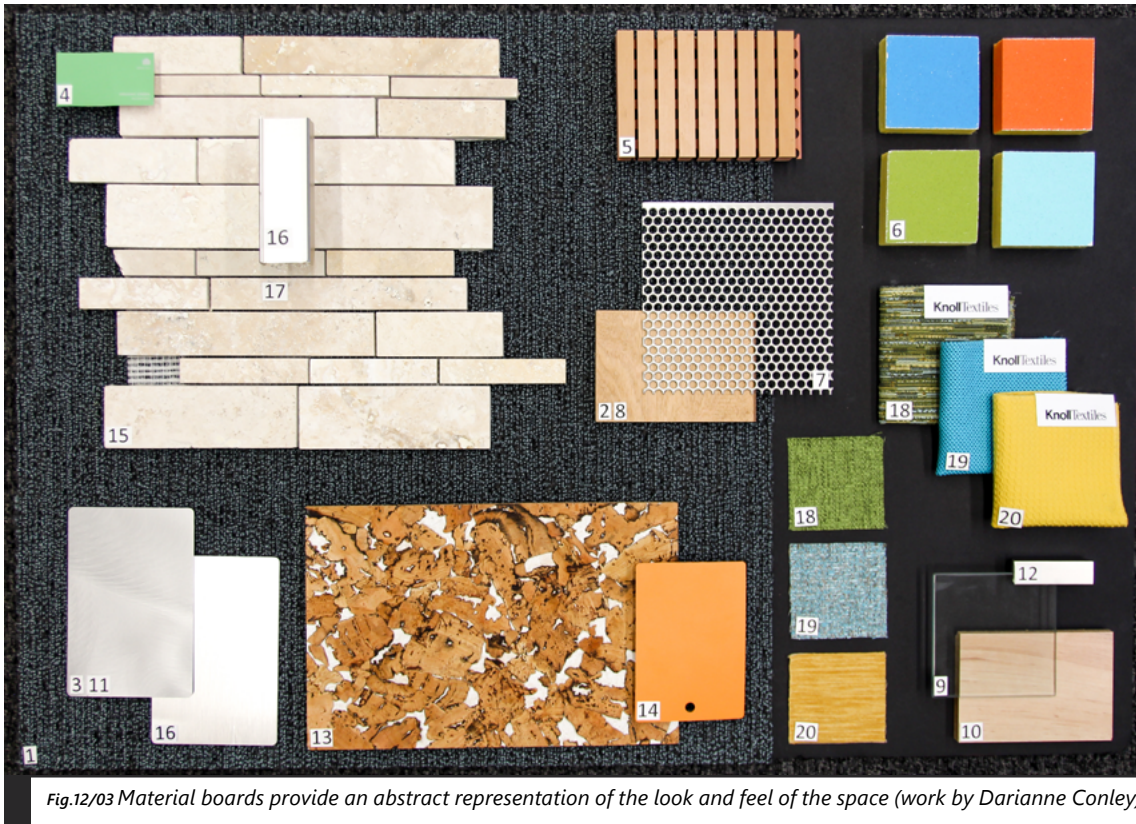

Fig.12/03 Material boards provide an abstract representation of the look and feel of the space (work by Darianne Conley).

and detailed written description of the materials, standards, tools, labor, and procedures required to fabricate and install the designed project. Specifications are provided as an intrinsic part of the construction document set and used in conjunction with construction drawings to accurately execute the designer's vision.

The construction drawing set and the specification documents should **coordinate perfectly**. In case there is a conflict, the specification document supersedes drawings according to the typical order of precedence.

Like any other component of the construction document set, specifications are integral to

the signed contract and are legally binding. Unclear expectations might return as subpar work or mistakes that might result in lawsuits. Badly written specifications are a major source of liability and a common source of legal claims. There are dedicated specification writers in the industry who can be hired as consultants, however, *it is essential for every interior architect and designer to understand what good specification writing entails; the designer is still responsible* for the errors and omissions, as the consultant is working under an agreement with the designer, and not the client.

There are 2 fundamental specification types, tailored towards two different purposes:

① An **open specification** outlines the expected properties of materials/products and results,

gives bidders the flexibility to decide on the specific manufacturer or variation among possible alternatives, determines the way the material/product will be processed and implemented based on the given description. It is open for alternatives and substitutions. Government contracts are required to be open.

② A **closed specification** states specific materials/products and their specific model and variation, requires specific processes, and declares the expected results. It does not typically allow for competitive bidding. It is typically closed for alternatives and substitutions, however, it is possible to bypass this with specific wording, for instance, “equal products can be used with the approval of the designer and client”.

The fundamental specification types can come in different formats customized to serve different needs. 4 most common types are as follows:

① **Performance specification** is an open type spec that describes a number of criteria and sets up expected results, what the finished installation is expected to accomplish. e.g. fire resistance ratings, VOC emission levels, or thermal insulation values.

② **Reference specification** is another open type spec that references standards and test methods set by widely recognized authorities, such as ASTM E648, NFPA 701, or UL 1715. Since these standards are so clearly defined, errors and liability are minimized.

③ **Proprietary specification** is a closed type specification where exact manufacturer name and products, even specific suppliers, can be stated. It is straightforward to write, relatively shorter and the designer is given absolute control.

④ **Base-bid specification** is another closed type specification; specific products are called out, however, the contractor is allowed to substitute other products. These substitutions should be subject to the designer’s review and approval.

via.12/02 Video on specification types and their uses.



Developed and published by the **Construction Specifications Institute (CSI)**, widely adopted by the construction industry, **MasterFormat®** is a guidebook that provides a standardized and systematically structured framework for specification, contract, and manual writing, helping to create a common language across the industry and setting-up a reference that minimizes misunderstandings. MasterFormat® features a six-digit indexing system to simplify searching for relevant information. In the latest version, there are 48 divisions relating to many aspects of construction including materials, equipment, furnishing, etc., but also, services, site and infrastructure, and processes. This organizational methodology is especially relevant when writing specifications, and the content is tailored accordingly. E.g. 09.21.16 refers to “Gypsum Board Assemblies” – or – 06.18.13 refers to “Glued Laminated Timber”.

SectionFormat®, or PageFormat® in Canada, is a specification formatting standard, also developed by Construction Specifications Institute and widely adopted by the construction industry. SectionFormat® divides the specification content into the following three parts:

① **General information about the project** – this part is the general summary of the job, including which MasterFormat® division/section it relates to, references, the extent and frequency of submittals, shop drawings, mock-ups, also, site conditions, access to amenities such as electricity and heat, delivery, storage, and handling expectations, as well as warranty conditions.

② **Information pertaining to products** – this part outlines which material will be installed

where, specific features, work to be performed prior to installation such as cutting, polishing, sealing; compliance with standards, certifications, and the general condition that the material should be in before installation.

③ **Information pertaining to execution** – this part outlines the implementation, including the examination of the application substrate, expected work to be completed by other teams prior to installation, substrate prep work to be completed, intended installation result, allowable tolerances and deviances, quality control, what will be done with the scraps, debris, and waste; cleaning, sealing, and protection, and lastly the general condition the installation should be in before substantial completion, in other words, before the owner takes possession.

The contractor uses the outlined specification information as well as the provided construction drawings, schedules, manuals, and catalogs supplied by the designer to realize the project. Specifications might also include a clause dictating that the installation must be signed off by the designer.

COST ESTIMATION

For an interior design professional, project cost estimation is an important skill for two reasons. First, there often is a limited budget associated with virtually every project, and knowing how much a design decision will cost can prevent late revisions that can possibly alter the aesthetics and impact of a project. Second, the client might be interested in learning the cost of a project early on, to plan ahead. A **ballpark estimate** or **ballpark figure** is the approximate cost of a project, can be given as dollar amount per square foot. Contractors and subcontractors can always give the designer a quote upon request, however, depending on the complexity of the bid and how busy their schedules are, this process might take days or weeks.

*A **quick cost estimate turnaround** is often important, especially in the initial stages of a project. This emphasizes the importance of the ability to self-estimate.*

There are many small but crucial aspects of estimation that require careful attention. First, an estimation includes more than the materials and workmanship; possibly transportation, handling, processing, purchase of various components, hardware, perishable tools, etc. Furthermore, the pricing of some of the items might fluctuate, one significant example being the threefold increase in lumber prices during the COVID-19 pandemic.

***Smaller costs add up** to considerable amounts, therefore creating a detailed spreadsheet and keeping track of all possible costs is extremely important.*

*The possibility of wastage and breakage should always be accounted for as unforeseen situations and **indirect costs** can add to substantial losses. Before making any calculations, learning about the standard increments of material orders, such as sheet size, roll width, linear feet/yard, tiles per box, coverage per roll, box, gallon, etc. helps with estimating possible wastage. **Mark-up** is used to cover the highly probable contingent cost, it should not be treated as a way to maximize profit. Accurate estimation requires significant experience and it is a skill that develops over time, as it is practiced.*

***Take-off** involves identifying and quantifying all the materials and items needed to complete a construction project in order to prepare the cost estimation. Even though it is possible to obtain drawings of a project site, with some luck and good will, from various sources such as local building department, realtors, previously involved contractors, or architecture*

offices. However, these drawing sets might be incomplete, or they might lack crucial information. Moreover, for understanding the current state of the project site, a visit is mandatory. **Accurate and detailed field measurements are an essential requirement for reliable cost estimations.** Also referred to as field surveys or site surveys, field measurements are useful in creating a detailed understanding of the physical context of the design project by clearly documenting existing site conditions. The very first thing to understand before attempting any field measurements is that no building is built perfectly. **There are always slight deviations from the actual architectural drawings, whether due to imperfect construction practices or simply because the building settled over time.** Such deviations have the potential to affect fabrication and installation processes, during which mistakes and oversight can be very costly.

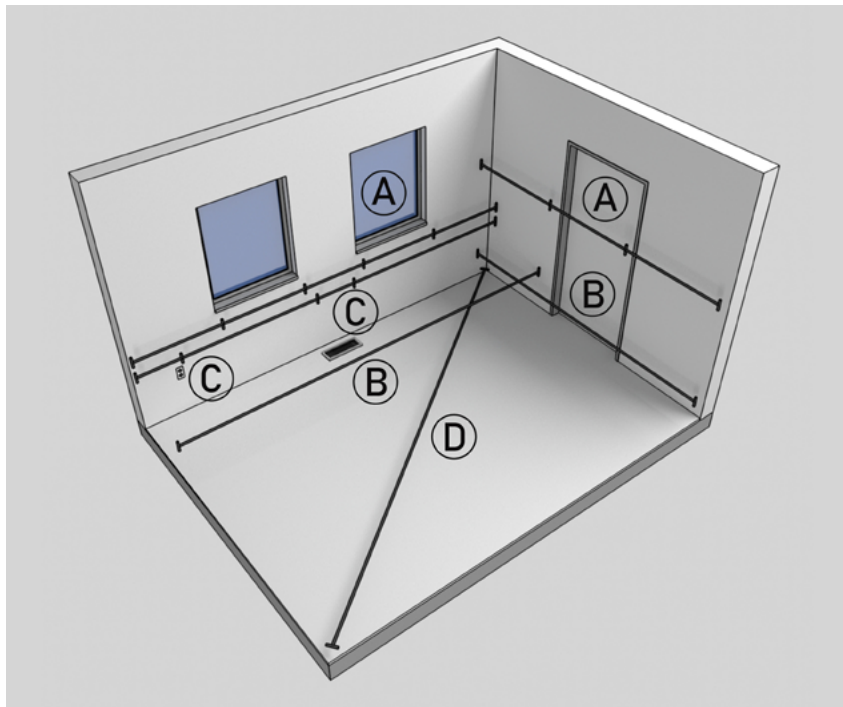

Fig.12/04 Points to measure: opening widths and distances to prominent features (A), total wall lengths (B), positions of electrical/mechanical details (C), diagonal lengths (D).



Fig.12/05 In order to reliably function, laser tapes require a flat surface to bounce the laser off of.

*The designer should not rely on a single set of measurements; they should make sure to have the contractor, or if applicable, subcontractors and installers **take their own measurements.***

The tools required for field measurements can be as brief as the following: a tape measure, clipboard, papers, pencils, and a camera. Tape length should be above 30' if possible and if long distances are anticipated a reel tape may be included in the inventory. **Laser tapes** are fast, precise, and very efficient in measuring long distances, on the other hand, there is always a need for a surface to bounce the laser off and one cannot work around every obstruction or smaller detail. By themselves, laser tapes are not sufficient and should always be accompanied by a manual tape measure.

When conducting field measurements, *one should always consider taking as many **photographs** as possible for further reference, as*

vid.12/03 Video on taking site measurements.



details and quirks of any space can be easily forgotten. These photographs should be augmented with specific notes. For instance, writing down if there is blocked site access, damp spots and mold growth on walls, or damaged electrical wiring, etc. **Reference points** and **diagonal measurements** are other seemingly redundant and often overlooked methods of measurement. Reference points can be any fixed point on site from which extra measurements can be taken and later compared. As buildings are not built perfectly, **multiple-point measurements** and **corner-to-corner diagonal measurements** give the designer more data to work with, therefore increasing accuracy. Lastly, **smaller details** such as switches and outlets, small niches, or protrusions should not be ignored and should be measured like any other general detail, as information pertaining to such details might later be needed.

*When conducting field measurements, refraining from spending **10 extra minutes** might cost hours later on.*

There are two different methods to approach cost estimation: one involving a simpler “total application area divided by coverage per material unit” formula, and the other involving detailed calculation of coverage and wastage per material unit. The first method will not be as accurate as the second, as wastage can be fairly significant for some applications. The second method is time-consuming, prone to mistakes due to its complexity, and the designer will still need to make room for various contingencies; but the designer will know what they are getting into and design in a way to make better use of the materials, which can be a huge benefit and a learning experience. When working on cost estimation, planning for contingencies is always important. It is common practice to add a 10% allowance over the material needed, however,

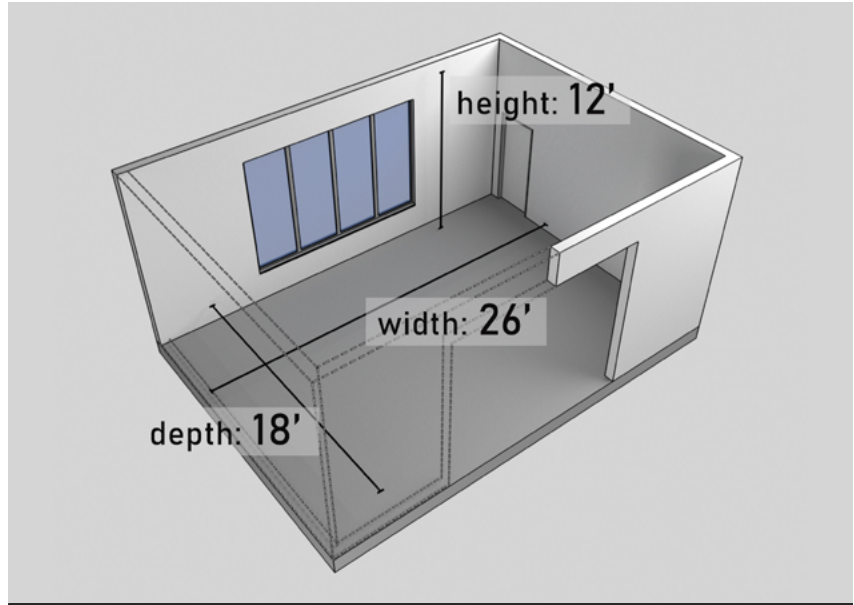

Fig.12/06 The imaginary space used for the example estimations.

if the application is complicated with multiple unknowns, it may be a better idea to increase the allowance up to 20%.

*The **actual cost** of the installation is more than the cost of material alone; the designer should add labor costs which will include job supplies, transportation, demolition, communication, etc.* It is often possible to find out a price range for labor per square foot; or per hour, which can be a little less useful unless how much work is done per hour is known.

*The **labor cost** will be higher than average if the job is complex, or slightly lower than average if it is straightforward.*

The following are simplified estimation steps for 3 different materials: paint, wallpaper, and carpet. In this example, the client wants to update their great room, which is 18' by 26', with a ceiling height of 12'; the room has a cased opening (12' by 10'), window opening (12' by 8'), and a door opening (36" by 84").

PAINT ● The room is expected to be painted with 3 coats of paint, with an average coverage of 350sqft per gallon. The amount of paint needed can be estimated with the following 5 steps.

First, the **perimeter length** of the room needs to be calculated. The perimeter of the room will be the total interior length of the given walls. In this case it is the length of two longitudinal walls (2 x 18') + two latitudinal walls (2 x 26') = 88' total perimeter. Following the perimeter calculation, the next step is finding the total **area of the walls** without considering any openings or details. The calculation is relatively straightforward for this room, which is a rectangular prism with a flat ceiling. The perimeter measurement of the room will be multiplied by the ceiling height. In this particular example, it is 88' x 12' = 1056sqft. In the case of an angled/vaulted ceiling this calculation methodology should be modified to incorporate the irregular wall area.

The third step is about determining **opening deductions**. The height and width of each opening should be multiplied and the result should be subtracted from the total area calculated in the previous step. In this case, there's a cased opening (12' x 10' = 120sqft), a window opening (12' x 8' = 96sqft), and a door opening (36" x 84" or 3' x 7' = 21sqft). The total opening area is 120 + 96 + 21 = 237sqft. This is the area that won't be covered by any material. The actual wall area to be covered is 1056sqft (assumed total wall area) - 237sqft (minus the openings) = 819sqft. The next step involves finding out the **total coverage** needed based on the number of paint coats. If the number of coats required is 3, the total resulting area to be covered would be 819sqft x 3 = 2457sqft.

The last step involves dividing the coverage of the material per unit by the total area to be covered. In this case, the amount of coverage is given as 350sqft per gallon, so 2457sqft / 350sqft = 7.02 gallons of paint will be required. As previously mentioned, *it is common practice to add*

a 10% allowance to most materials, as there will be mistakes and wastages. 7 gallons x 1.1 (10% added) = 7.7 and rounded up to 8 gallons should suffice for the project. If you assume a high-quality eggshell paint is \$35 per gallon, 8 x 35 = \$280 worth of paint will be needed.

The total labor cost can be calculated based on the total painted area, which was previously calculated as 819sqft on the third step. For practicality, paint labor is assumed to be between \$1 to \$3 per sqft. Considering the job at hand is fairly straightforward, 819 x \$1 = \$819. A 10% additional budget can be dedicated for various other costs associated with the application, 819 x 1.1 (10% added) = \$900. The total expected cost for the paint application including labor is 280 + 900 = \$1180, approximately.

WALLPAPER ● The next problem is calculating the required materials for a wallpaper application for the same room. This is a residential project, *so researching and finding out the common dimensions for available products should be the initial task.* For simplicity, it is assumed that there are two wallpaper types available: 20.5" wide rolls with 33' double roll length, covering approximately 55sqft. The alternative roll is 27" wide rolls with 27' double roll length, covering approximately 60sqft.

Wallpapers are typically cut into strips and then



Fig.12/07 Wallpaper roll length determines how many useful strips can be extracted as well as the wastage.

applied. The height of the space is 12', therefore, it is possible to extract 2 strips per double roll on the 20.5" wide type, covering 41" wall length per roll, with a 9' strip left to spare; and 2 strips on the 27" roll with a 3' strip to spare, covering 54" wall length per roll. However, considering that pattern matching might require 12", 18", or 36" strip offsets, the 3' extra length might or might not be adequate.

The perimeter of the room is 88', and there are two 12' wide and one 3' wide openings. $88' - (2 \times 12') - 3' = 61'$ of the wall perimeter need to be covered with full height strips. Additionally, there's a 2' by 12' area over the cased opening, 3' by 5' area over the door, and 4' by 12' area around the window to be covered. $61' \times 12' = 732'$ perimeter to be covered by 20.5" wide strips, requiring approximately $732 / 20.5 = 36$ strips, which will be extracted from 18 double rolls each with a 9' strip to spare. The area above the door will require two 5' high strips. The cased opening runs for 12', that is 144" requiring seven 2' high strips to cover. The area below and above the window are 12' long, similarly, there's a need for seven 2' high strips to cover the top and the bottom section. All these strips can be extracted from the eighteen 9' high leftover strips. If 10% contingency allowance is added 18×1.1 (10% added) = 20 double rolls, rounded up to the closest even number as wallpapers are commonly



Fig.12/08 Seaming iron is one way to join carpet seams. More seams mean more labor and increased cost.

sold in double rolls.

*A simpler but less accurate calculation would involve dividing the area **coverage per double roll by the total area** to be covered.* According to step 3 of the paint calculation, a total of 819sqft needs to be covered. Considering the chosen wallpaper covers 55sqft per double roll, $819\text{sqft} / 55\text{sqft} = 14.8$ double rolls will be needed at a minimum. However, considering the room height is higher than the average and there are numerous openings, substantial wastage should be expected. So instead of the usual 10% allowance, a 20% allowance will be added, 14.8×1.2 (20% added) = 18 double rolls, rounded up to the closest even number. As seen in this example, basing calculations on simple square footage might be slightly inaccurate and risky.

CARPET • Finally, a carpet calculation will be done for the same room. A standard broadloom carpet roll is 12' wide. Since the room for the application in question is 18' by 26', it is possible to set the carpet run on the longitudinal axis and get away with a single seam but there will be some wastage. For this particular room, a 12' wide carpet roll and a 6' wide carpet roll with a length of 26' should suffice, at least in theory. However, *each time the carpet is cut, 6" width should be added along the length of the cut for a **clean edge**.* As a result, $27' \times 2 = 54'$ long broadloom carpet will be needed. There will be a 27' by 5.5' (due to 6" loss per cut) wastage from the application. So, with the 10% allowance, $54' \times 1.1$ (10% added) = 60' long broadloom carpet will be needed, rounded up to the closest number. *With a single seam it is easier to **adjust the nap**,* however, it is also possible to apply the carpet on the perpendicular, latitudinal axis, creating more than one seam. This time three 18' long carpet rolls will be needed, still amounting to the same length of carpet, $18' \times 3 = 54'$. The wastage will be 18' long and 9.5' wide as opposed to the 27' by 5.5' previously calculated, an additional 22.5sqft carpet will be wasted and there will be more seams adding to the labor costs.

SPECIFICATION CRITERIA

When specifying materials, a wide selection of criteria need to be considered; and for each criteria, there are various questions, the answers of which affect the experience, impact, longevity, and overall success of the material choice. The specification criteria can be grouped under three broad categories: ① Concept / Budget / Performance Concerns, ② Health / Safety / Accessibility Concerns, ③ Sustainability / Maintenance Concerns. These categories contain several subcategories each with associated questions that can guide the designer to a more efficient material specification.

The designer should understand that, due to the

complexity of the material specification process, a **holistic approach** to the content is more appropriate than a sequential approach. For instance, a seemingly suitable material might tick all the boxes but might fail to withstand the required cleaning practices, or it might be impossible to import, or it might release toxic fumes when combusted; basically a single criterion rendering the otherwise perfect match unsuitable.

*The criteria provided here aim to remind the designer of the **comprehensive and complex** nature of material specification process, help prioritize between alternatives, and prevent any oversight.*

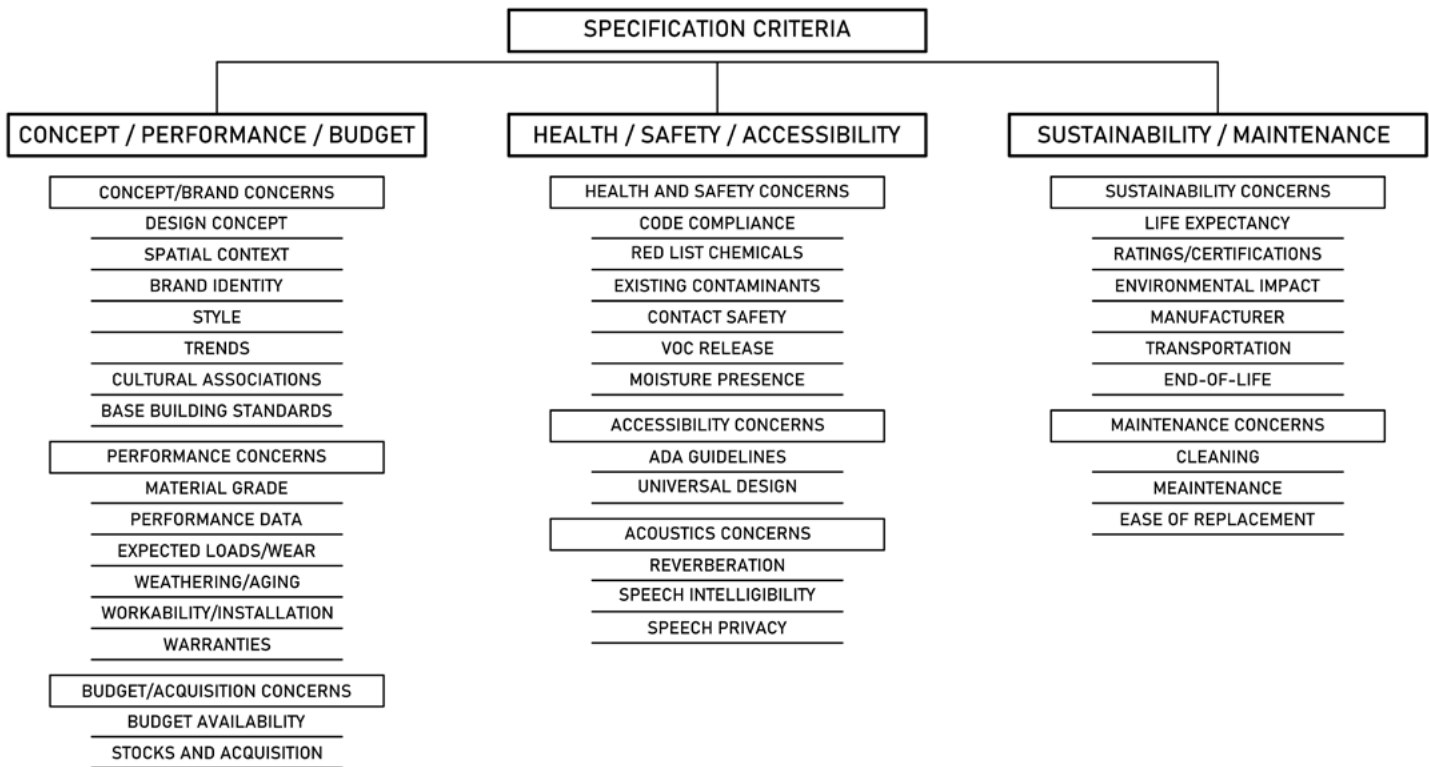

Fig.12/09 A holistic approach to the categorized map of material specification criteria is more beneficial for most projects.

CONCEPT/BRAND CONCERNS

DESIGN CONCEPT • *Concept* is useful for creating a consistent and coherent design language, and materiality is one part of it. The designer should ask what category and type of material would strengthen the overall expression of the design intent, in a manner that would work with the rest of the design decisions. The designer should further consider that the impact of the material is also dependent on where and how much it is used. The same material used as an edge accent won't have the same effect as covering large surfaces. Moreover, materials have to work in conjunction with others and the total effect might enhance or weaken the impact.

Tab.12/01 Questions regarding design concept.

(1) What type/category of material does the concept suggest?
(2) What surface quality does the concept suggest?
(3) What kind of finish does the concept suggest?
(4) What material combinations does the concept suggest?

SPATIAL CONTEXT • The designer should consider if the material specification is appropriate for the given spatial context. *The features of the space impact how the material will be perceived*; the context can highlight positive qualities of the material, as well as exacerbate negative features. For instance, large format tiles might work better in larger spaces compared to the standard 12" by 12" tiles, due to a more sensible proportional relationship. Or a space with large south-facing windows might suffer from excess glare if the materials specified are mostly dark and polished.

Tab.12/02 Questions regarding spatial context.

(1) Does the space have any unique features to influence material perception?
(2) How will the material synergize with other materials that make up the space?

BRAND IDENTITY • When working within a commercial context, the communication of corporate

image and branding carries significant importance. **Branding** is not limited to using the colors or forms implied through branding elements, such as logos, typeface choices, web design packaging, etc. but it is also about finding the right materials to communicate and reinforce the message, position, and reputation of the brand. For instance, for a luxury apparel brand, using exposed OSB panels as part of a material scheme might be a wrong decision, unless some industrial and carefree brand implication is in place.

Tab.12/03 Questions regarding brand identity.

(1) Does the material choice enhance or weaken the brand message?
(2) Does the material scheme reference the branding elements?
(3) Does the material choice agree with user/client expectations?

STYLE • *It is very likely for an experienced designer to develop a formal style over the years, based on what they believe works and distinguishes their work from the competition.* However, stylistic specification choices should not clash with other design considerations as they are primarily serving the designer and not so much the design product, user, and in most cases the client.



Fig.12/10 The logo is a great source for color, texture, and finish inspiration when specifying materials.

Tab.12/04 Questions regarding style.

- | |
|---|
| (1) Do the stylistic choices enhance or hinder the design intent? |
| (2) Are the stylistic choices serving the designer or the design product? |

TRENDS ● *Trends help the designer to identify what is generally accepted as a desirable design choice at a certain period in time.* Some trends last 10 years, others might last a season. The designer should follow what the current trends are, which materials or color schemes will be “in” at the time of project completion. However, trends do not apply to all projects. For a residential project, the trending paint colors might be a good choice depending on the client’s wishes, but when designing the headquarters for a financial corporation, a more timeless and lasting choice might be better justified.

Tab.12/05 Questions regarding trends.

- | |
|--|
| (1) How significant are the trends on the perception of the design product? |
| (2) Does the overall effect intended to be contemporary or classic? |
| (3) How well do the prominent trends overlap with client’s identity and message? |
| (4) How much value is put on trends by the client and the targeted users? |

CULTURAL ASSOCIATIONS ● Some materials have strong cultural associations and implications that can substantially affect user experience, in a positive as well as negative way. *The designer should be especially careful when working within a new cultural context they are **not familiar with**, continuously calculating the possible negative and positive meaning that can be derived from material choices.*

Tab.12/06 Questions regarding cultural associations.

- | |
|--|
| (1) What are the cultural/sub-cultural sensibilities of the target users? |
| (2) Are there any religious/cultural values that disqualify certain materials? |

BASE BUILDING STANDARDS ● The space to be designed might be located within a larger building or community, and it is possible that some standards have been established by the owners/members; such as signage sizes, or style of the exterior facade, or the approved window treatments, or types of ceilings on the interior, or the times of day work can be done, or the size of materials, furniture, and fixtures that can be delivered, or how the construction waste will be removed.

*The designer should request the associated **base building manual** and carefully inspect it before starting to specify materials and finishes.*

Tab.12/07 Questions regarding base building standards.

- | |
|---|
| (1) Is there a base building manual available, and if so, how can it be obtained? |
| (2) Are there any items in the base building standard impacting material choices? |

PERFORMANCE CONCERNS

MATERIAL GRADE ● *A very straightforward way to classify materials according to performance is indicating if they are manufactured for **residential** or **commercial** use.* Residential grade products are typically less durable and more prone to failure as they are expected to receive lighter traffic, abuse, and cleaning. On the other hand, commercial grade products are developed to withstand heavier traffic, abuse, and cleaning practices. The designer should be very careful in determining if the material being considered appropriate for the intended use.

Tab.12/08 Questions regarding material grade.

- | |
|---|
| (1) Is the designed space categorized as residential or commercial? |
| (2) Can the traffic load be described as heavy, medium, or light? |

PERFORMANCE DATA • *The measured performance data of materials, often provided on the product label, are a crucial **indicator of the suitability** to the intended situation.* Hardness, colorfastness, UV resistance, lightfastness, expected deformation, or warping should all be considered carefully for the specific use context. The designer should be familiar with various technical terms, what they indicate, and how they might compare. For example, the Wyzenbeek Double Rubs, indicate the resiliency of a piece of textile-based on a particular abrasion method. On the other hand, the Martindale Abrasion Test involves a lighter abrader and a different movement pattern, and it takes more cycles for the fabric to fail. The designer has to know this information in order to make a healthy comparison.

Tab.12/09 Questions regarding performance data.

(1) How much the material can withstand the expected compression, tension, and shear forces?
(2) Is the material dimensionally stable, resistant against cupping, warping, bowing?
(3) What is the hardness, abrasion resistance, surface resilience of the material?
(4) How do the UV resistance, colorfastness, and lightfastness data of the material look?

EXPECTED LOADS/WEAR • *Performance data is closely tied to the expected loads and wear and the designer should interpret them **in conjunction**.* For example, the hardness of the product makes sense when it is considered in relation to the expected circulation traffic or rolling loads such as carts, task chairs, dollies, or wheelchairs. The abrasion resistance numbers make sense when the frequency of cleaning and the expected abuse is considered. Crocking resistance is similarly connected to expected abrasion and wear but refers to how well the color will be maintained on a textile. If UV exposure is expected UV resistance and lightfastness are values to carefully consider.

*Products with higher performance values can be proportionally expensive and finding the most appropriate product is also a **budget issue**.*

Tab.12/10 Questions regarding expected loads/wear.

(1) Is there an expectation of heavy cleaner or other chemical exposure?
(2) Is there an expectation of prolonged UV exposure?
(3) Is there an expectation of heavy foot traffic, rolling, and persistent loads?

WEATHERING/AGING • *Materials weather and age depending on environmental conditions, but also how they are finished and protected. The designer should consider conditions like UV exposure patterns, intensity of snow and rain, proximity to saltwater bodies, adjacent materials, etc. **Weathering and aging happen over time, and unless the material is chemically pre-weathered, and the designer should consider the imminent transformation.*** Another issue is the maintenance and replacement of components, which might cause undesired visual inconsistencies.

Tab.12/11 Questions regarding weathering/aging.

(1) What is the expected weathering after 2, 5, and 10 years?
(2) How will weathering discrepancies impact adjacent materials?
(3) Will the weathering leave irregular patterns when fully exposed over extended periods?
(4) How often will the weathered components require replacement?

WORKABILITY/INSTALLATION • *The workability of a product directly affects fabrication and installation costs, but also the amount of wastage. **Low workability can negatively impact budget management while limiting possible design choices.*** For instance, travertine is fragile and has a slow setting time, making it time-consuming and expensive to install. Complex matching patterns in upholstery can increase wastage

while complicating the fabrication processes and straining the budget.

Material manufacturers typically suggest appropriate adhesives, finishes, etc. to be used for each product and the designer should make sure to review fabrication and installation instructions, moreover, they should also make sure these are noticed by the fabricator and installer. Not all materials are suitable for all available fabrication and installation methods. For example, a CNC cut carpet inlay won't work with a stretch-in installation.

The designer should consider how much risk they can afford when specifying an unpredictable product. Furthermore, *finding and scheduling the right craftsman or installer might be another challenge when specifying less workable materials.* Another important consideration when specifying materials is the roll, sheet, tile, etc. sizes. Most materials are manufactured according to industry-wide size standards. Knowing these and designing accordingly can minimize wastage significantly.



Fig.12/11 Complex details with low tolerance require impeccable workmanship, often stressing project schedule and budget.

Tab.12/12 Questions regarding workability/installation.

(1) Is the material predictable or risky, in relation to fabrication complexity?
(2) What are the typical workmanship costs and craftsman availability?
(3) What are the manufacturer's suggested fabrication and installation methods?
(4) Will there be a need for test applications or prototyping?
(5) What is the typical roll, sheet, tile sizes for the material and expected wastage?

WARRANTIES ● The designer should consider the express and implied warranties associated with the materials and products being considered. *Warranties should be thought in relation to the expected term of use.* For a pop-up retail that will be torn down after 12 months, using a product with a 10-year warranty may not be well justified. It is important to understand the conditions and guidelines that make up the warranty, including the conditions that void the warranty.

*Longer warranties often indicate the manufacturer's confidence in a product, but the **initial cost** of the product will be naturally higher.*

Tab.12/13 Questions regarding warranties.

(1) What are the manufacturer's warranty conditions and guidelines?
(2) Are the warranty conditions and period overlap with intended use?
(3) How stringent are the listed conditions that void the warranty?

BUDGET/ACQUISITION CONCERNS

BUDGET AVAILABILITY ● It is always a good idea for the designer to know the budget they will be working with and assess what they can and cannot afford. *Failing to be conscious about the budget might result in **over-promising and under-delivering.*** The designer should consider if they are aiming for visual impact or longevity of use.

Usually there's a more budget-friendly material alternative available, but one needs to consider that the cheaper alternative might not last as long, or it may contain more defects on average, or lack comprehensive warranties, or be less workable overall. *There's also the possibility of receiving **discounts**, which might affect what can ultimately be done with the budget.*

The designer should consider that elaborate designs with intricate details will end up inflating workmanship costs, might require higher quality materials, and in some cases drive up wastage as well. Such intricate and expensive ideas should be reserved for higher-priority spaces that are expected to receive heavy foot traffic and act as a showcase. Straightforward designs realized with commonly used materials can cut costs significantly. Lower priority spaces with minimal foot traffic such as storage or printer rooms can feature relatively lower quality materials to balance the budget.

Tab.12/14 Questions regarding budget availability.

(1) Are there any discounts available for the intended materials or alternatives?
(2) Will the overall impact of the implementation justify the associated costs?
(3) Can the design details be simplified and streamlined to control costs?
(4) What are the costs in the long run, regarding maintenance and replacement?

STOCKS AND ACQUISITION • Besides the limitations posed by the budget, *the designer should also pay close attention to **stock availability, lead times, delivery times, and the possibility of backorders.*** Transportation and handling will add to the unit costs; for some materials and for some products this cost difference can be considerable. If the order is custom made, there's a possibility of delivery dates being pushed for weeks. Lastly, there's always a possibility of a product being discontinued. Even though most of the time alternatives are available, availability

and delivery times still need to be considered for the alternatives as well. It may be important to order extra materials for future repairs and replacements, as products may discontinue or future orders might fail to match the calibration code or dye lot. This extra order of materials is sometimes referred to as the "attic stock".

Tab.12/15 Questions regarding stocks and acquisition.

(1) Is the material in stock and immediately available upon order?
(2) What are the associated shipping, transportation, and moving costs?
(3) What is the expected delivery time and are there any contingencies?
(4) If the material is rare or custom-made, what is the expected lead time?
(5) For a non-US manufacturer, is there a distributor or is importing possible?
(6) If the material acquisition is problematic, what are the alternatives?
(7) Should extra materials be ordered for future repairs and replacements?



Fig.12/12 Frequently ordered products are often kept in stock and can be delivered relatively quickly.

HEALTH AND SAFETY CONCERNS

CODE COMPLIANCE ● It is important to know *if the designed space is **heavily or lightly regulated** and if there will be risky activities performed or hazardous materials to be present*. This is important to know from the get-go, to balance the budget and learn about material availability for some applications.

It is imperative to check the code requirements for the occupancy type(s) associated with the designed space (see IBC Chapter 3) as they dictate what standards need to be met (see IBC Chapter 8). For instance, a machined MDF panel application on a fire exit access corridor in a non-sprinklered multi-story restaurant (Occupancy Type A-2), needs to be rated ASTM E84, Class A. However, a typical MDF board is Class C. Class A boards are not only more expensive, they are also not immediately available. Therefore, planning early on for the code requirements can save costs and time.

*It is always very useful to discuss critical codes with the **local building department** to understand how they will be interpreted.*

Tab.12/16 Questions regarding code compliance.

(1) Is the space lightly regulated (low risk) or heavily regulated (high risk)?

(2) What is the code requirement for the determined occupancy type(s)?

(3) When in doubt, has the local building department been contacted for clarification?

RED LIST CHEMICALS ● *The designer should know about **harmful chemicals** potentially found in materials.* The Living Futures Red List is a great source to learn about these chemicals, though there are other sources such as the Transparency Database by Perkins + Will. Some of these chemicals are deemed safe by the EPA when the exposure is limited, such as BPA and Form-

Link 12/02 Visit the Living Future Red List database.



aldehyde. However, it may be a better practice to refrain from specifying materials containing these chemicals, especially when sensitive user groups are involved such as developing children and pregnant women.

Tab.12/17 Question regarding Red List chemicals

(1) Does any chemical component of the material included in the Living Future Red List?

EXISTING CONTAMINANTS ● *It is highly likely that buildings that were built **before the 1980s** contain harmful contaminants such as lead and asbestos.* Consequently, any project to be conducted in such buildings demands careful planning. Materials requiring the substrate to be demolished, replaced, scraped, or sanded may cause unwanted chemicals to resurface and be released to the environment in the form of invisible particles.

If the building is built before 1978, there's a chance that lead paint and plumbing components might be present. If the walls are expected to be demolished or at least scraped, it is important to get a lead removal professional involved. Similarly, for buildings built before 1986, there's a possibility of asbestos insulation materials and/or asbestos composite finishes being present. According to the current research, it is safe to leave asbestos sealed and undisturbed. However, as soon as a disruption is planned, it is important to get asbestos abatement professionals involved.

Tab.12/18 Questions regarding existing contaminants.

(1) Was the building to be remodeled constructed before the 1980s?

(2) Will any substrate be demolished, replaced, scraped, or sanded?

CONTACT SAFETY • Certain user groups and activities require careful consideration when specifying materials. *If **infants or small children** are expected to be present in a space, the impact of harmful chemicals can be severe, and the designer should plan accordingly.* The US Consumer Product Safety Commission (CPSC) has published a broad range of guidelines on children’s products.

*If **food contact** and preparation are expected on a surface, the material should be carefully specified.* For commercial food production, the designer should refer to industry regulations. For instance, Corian meets NSF/ANSI Standard 51 for food contact surfaces and safe to specify, but some alternative solid surfaces that may not meet the same standard and won’t be suitable.

Tab.12/19 Questions regarding contact safety.

- | |
|--|
| (1) Will there be developing children be present in the environment? |
| (2) Is frequent food contact expected with the specified surface? |

VOC RELEASE • *Even though the intensity may vary considerably, the designer should acknowledge that all materials **release VOCs**, whether directly or through utilized adhesives or sealers.* For most materials, it is often possible to find and specify



Fig.12/13 Being in frequent contact with harmful chemicals significantly impair child development.

alternatives that have lower VOC emissions that occur over a shorter period. Greenguard certification is a good reference for assessing VOC emissions. The designer should be careful that some materials can first absorb and then emit VOCs over a longer period than the original source. Drapery and upholstery often carry this particular risk, and it is better practice to introduce such materials to the space after an initial off-gassing period. Heat and humidity of the environment can also boost VOC emissions, and the designer should carefully consider the material’s proximity to these elements.

*The ventilation conditions of the environment affect how well the VOC emissions can be tolerated; however, the designer should know that the **average occupant** does not ventilate as often as advised.*

Tab.12/20 Questions regarding VOC release.

- | |
|---|
| (1) What is the expected VOC release intensity and fall-off over time? |
| (2) Is the schedule planned to accommodate an initial off-gassing period? |
| (3) Are there any absorptive materials expected to be present in the environment? |
| (4) Is the material in proximity to heat and moisture sources? |
| (5) Does the environment provide automated or easy-to-use ventilation? |

MOISTURE PRESENCE • The designer should always consider that the presence of moisture and unprotected organic content create a risk for unwanted organisms to thrive. Therefore, *materials that might **absorb, retain, and transfer** moisture should be specified carefully, in relation to their environment.* The presence of moisture is not always obvious, it could be the water vapor produced during cooking, splashes of water when bathing, a leaking pipe behind a wall, or condensation through thermal bridges. The designer should pay attention to the moisture condition of the substrate, the amount

of work needed to direct water away, curing requirements, corrosion or deterioration expectancy, etc. Below-grade applications should always assume moisture exposure and incorporate a moisture barrier.

Tab.12/21 Questions regarding moisture presence.

(1) Will there be excess moisture building up in the environment?
(2) Can the material absorb, retain, and transfer moisture?
(3) Can the material content be consumed as food by household pests?

ACCESSIBILITY GUIDELINES

ADA GUIDELINES ● The designer should be aware of the various ADA **accessibility guidelines** that specifically apply to materials, such as height difference between two flooring materials, transitions, slip resistance, pile depth, etc. Even though ADA guidelines outline the minimum, it is always possible to go beyond and exceed these requirements. For example, utilizing color and texture to enhance wayfinding for users with limited cognition or subduing reflected glare to accommodate people with declining visual acuity.

Tab.12/22 Question regarding ADA guidelines.

(1) Are ADA accessibility guidelines pertaining to materials met and exceeded?
--

UNIVERSAL DESIGN ● Universal design principles call for an awareness of the fact that *there are individuals with widely varying abilities, and a fully healthy person is never a good archetype to base design decisions on.* The designer should consider the impact of material specifications on a range of individuals, whether they are disabled or not. For example, forcing the elderly in a public building to walk and wait on granite flooring is hard on their joints, so a material that introduces some flexibility is justified. Furthermore, universal design often accomplishes

higher comfort and enjoyment for all members of the society. It is very possible that this flexible flooring material will be comfortable for the fully healthy individual as well.

Tab.12/23 Questions regarding universal design.

(1) Are there any occupants with limited or different abilities expected to be present?
(2) Will there be elderly, or children present who can benefit from unique material properties?

ACOUSTICS CONCERNS

REVERBERATION ● *Acoustic properties of a room are important for the comfort and wellbeing of the user and should be considered in conjunction with the function and activities.* An excess of reflective surfaces within a high/deep volume would encourage the sound to travel farther before diminishing, reverberating for many seconds. Even though some amount of reverberance can be desirable in an environment like a chapel or a live concert hall, it is usually not desirable as the overlap of the reflected sound with the original source causes intelligibility problems. The designer should consider the size and shape of the room and envision how to balance reflective and absorptive materials to achieve a desirable acoustic environment.

Tab.12/24 Questions regarding reverberation.

(1) Is the shape of the room expected to intensify reverberation?
(2) What is the proportion of reflective surfaces to absorptive surfaces?
(3) Is there any expectation of live music to be performed in the space?

SPEECH INTELLIGIBILITY ● Most spaces will feature a speaker and a listener, and how clearly the sound is transmitted in between the two can be a significant concern. *The designer should first consider the distance at which the speech should be intelligible and employ reflective as well as absorptive materials to carefully direct*

the sound. For example, in a large classroom, one would expect the sound to reach the back of the room but not reflect and come back. On the other hand, in an open office one might want to hear what their close-by team member is saying but wouldn't want the sound to travel far. In complicated cases such as conference halls or live music venues, it is highly beneficial to hire acoustics consultants.

Tab.12/25 Questions regarding speech intelligibility.

- | |
|--|
| (1) Is the space open plan and is sound clarity at a distance a concern? |
| (2) Will there be a large audience to be addressed from a distance? |
| (3) Is the acoustic quality of the environment vital, justifying a consultant? |

SPEECH PRIVACY ● The designer should consider if there will be any private conversations occurring in the environment to be designed. *For some environments, where **confidential information** is exchanged such as examination rooms, meeting rooms, or bank booths, the conversation should only be intelligible to the people involved and should not be understood by anyone else.* The designer should consider utilizing absorption, blocking the path of the sound, minimizing flanking, and when needed, incorporating an ambient sound source for masking.

Tab.12/26 Question regarding speech privacy.

- | |
|--|
| (1) Will the space feature an exchange of sensitive information? |
|--|

SUSTAINABILITY CONCERNS

LIFE EXPECTANCY ● When specifying a material, *the designer should always consider the **expected useful life** of a material/product and the maintenance requirements to achieve the longest possible service.* The maintenance aspect is important because one might expect a wood countertop to last decades with good care. However, users can be neglectful or lack the knowledge and expertise for proper maintenance.



Fig.12/14 Both speech intelligibility and privacy is an important concern in the modern office environment.

nance. For some cases, an extended life expectancy for the material is not justified. For instance, in spaces that are remodeled frequently, such as expo stands or retail displays. In these cases, recyclability and minimizing landfill contribution should be the goal.

Tab.12/27 Questions regarding life expectancy.

- | |
|--|
| (1) What is the expected useful life of the material under normal use? |
| (2) Will the material deteriorate quickly without strict maintenance? |
| (3) Is the material intended for temporary or permanent use? |

RATINGS AND CERTIFICATIONS ● Most contemporary materials feature one or more of the many sustainability, health, and safety labels that are widely recognized. *The designer should be willing to learn what each label implies and use them as a **comparison tool** to make the best decision.* Another important concern related to material specifications is the sustainability certifications such as LEED, Living Building Challenge, and WELL Building Standards, all of which require a set number of credits to be

earned or minimum criteria to be met. Materials often play an important part in achieving these certification goals.

Tab.12/28 Questions regarding ratings and certifications.

(1) Does the material feature any sustainability, health, and safety labels?
(2) Are the featured ratings and certifications recognized by the industry?
(3) Does the material contribute credits towards sustainability certification?

ENVIRONMENTAL IMPACT • *The designer should consider the impact of how the material is sourced, refined, and processed.* Some materials are rapidly renewable and do not deplete existing resources, whereas others cause deforestation, loss of habitat, and biodiversity. Some mining byproducts are bio-accumulative and can move up the food chain, whereas others can be filtered and reused within a closed-loop system. The designer should be careful when specifying materials that support destructive industry practices.

Tab.12/29 Questions regarding environmental impact.

(1) Is it possible to track how the material is sourced, refined, and processed?
(2) Is the source of the material rapidly renewable, or at least renewable?
(3) At any stage, does the material cause bio-accumulative residue output?
(4) Does the manufacturing of the material cause environmental destruction?

MANUFACTURER CONCERNS • *The designer should always research and assess the manufacturer's commitment to sustainability.* This ultimately reflects how much money, care, and attention has been invested in manufacturing a product in an environmentally friendly manner. Another issue is if the manufacturer provides humane working conditions or not. Some manufacturing processes can be especially toxic, even though the final product is not.

Continuing to specify products from manufacturers that employ unsustainable and unhealthy practices might encourage others to follow suit.

Tab.12/30 Questions regarding manufacturer concerns.

(1) Does the manufacturer clearly express commitment to sustainability?
(2) Does the manufacturer provide humane working conditions?

TRANSPORTATION CONCERNS • The designer should know that a material can be rapidly renewable and sourced with minimal embodied energy, however, *if it is being transported from the other side of the globe, it still generates a considerable carbon footprint.* The designer should employ a holistic view and consider the overall impact rather than focusing on a single facet of sustainability at a time. Packaging is also a concern for some products. Manufacturers that employ fully recycled packaging practices generate much less landfill contribution compared to those that don't.



Fig.12/15 Transportation accounts for 21% of the global carbon emissions.

Tab.12/31 Questions regarding transportation concerns.

- | |
|---|
| (1) Are there local alternatives for the material (within a 500-mile radius)? |
| (2) Does the manufacturer employ fully recyclable packaging? |

END-OF-LIFE CONCERNS ● It is crucial for the designer to think about what is going to happen to a material/product when it concludes its useful life. Some materials can be refinished and reused, others can be repurposed, and others can be recycled at varying success rates. *The designer should try to specify materials that have **established and feasible** recycling practices in place.* For instance, inappropriately specified nylon carpet under heavy traffic would wear down quickly, and with no option to be repurposed and only partially recycled it will end up in a landfill.

Tab.12/32 Questions regarding end-of-life concerns.

- | |
|--|
| (1) Can the material be reused or repurposed at the end of its useful life? |
| (2) Are there established and feasible recycling practices for the material? |

MAINTENANCE CONCERNS

CLEANING CONCERNS ● The designer should consider if the cleanability features of the material are appropriate for the specified context. For instance, if mud tracking, spills, and staining is expected, a porous and absorbent material like cork would not be appropriate. Furthermore, *some **cleaning practices** are highly abrasive and rely on the use of heavy-duty chemicals*, such as those utilized in healthcare. These cleaners might corrode or disintegrate some materials.

As a rule of thumb, complex/organic/randomized patterns tend to hide soiling and wear better than solid flat colors/geometric patterns. This is especially useful when heavy traffic loads



Fig.12/16 A complex organic texture can help in hiding dirt and wear.

are expected. Additionally, carpets with dense piles and fuzzy appearance help hide soiling and track marks.

Tab.12/33 Questions regarding cleaning concerns.

- | |
|--|
| (1) Is the material compatible with common green cleaning strategies? |
| (2) Does the expectation of spills, dirt tracking, and staining justify high cleanability? |
| (3) Will the material undergo heavy cleaning with highly abrasive cleaning chemicals? |

MAINTENANCE CONCERNS ● Some materials require very specific care and periodic maintenance over their lifetime, in order to sustain their look and performance. For instance, silk is famously hard to care for, on the other hand, cotton can take significant neglect and abuse. The same is true for hardwood flooring vs. porcelain flooring.

*The **average user** is not very capable of maintaining materials, and professional attention can be costly and should be a factor when deciding material specifications.*

Tab.12/34 Questions regarding maintenance concerns.

(1) Can the client afford the time and money required to maintain the material?

(2) Will there be a need to store additional materials (attic stock) for future repairs?
--

EASE OF REPLACEMENT ● Some parts or sections of an application can abrade under load or break quicker than other parts, requiring replacement. *If it is possible to easily remove and **replace worn sections** with little effort and visual inconsistency, it can save the cost of replacing the entire surface.* For instance, solid surfaces can be spot patched and buffed repeatedly, and gain a new look without limitations posed by unit size or color calibration. On the other hand, patching a laminate is countertop is not possible, at least in a reliable and desirable manner. It is also important to consider that in some cases, replacement or disassembly might be necessary and design details should also be developed accordingly, without compromising the integrity of the application. For example, the peelability and strippability properties of wallcoverings can determine how much damage the substrate will sustain during removal.

Tab.12/35 Questions regarding ease of replacement.

(1) Can the design benefit from modular units and installation?

(2) Can the worn parts or sections be repaired, patched, and buffed repeatedly?

(3) Can the material be removed without damage to the substrate or assembly?
--

(4) Can the materials be disassembled and repurposed for another project?

SELECTED BIBLIOGRAPHY

Allison, Diana. *Estimating and Costing for Interior Designers: A Step-by-Step Workbook*, Fairchild Books, 2014.

Ashby, Mike. *Materials and the Environment: Eco-informed Material Choice*, 3rd Ed. Butterworth-Heinemann, 2021.

Ballast, David Kent. *NCDIQ Reference Manual*, 6th Ed. PPI a Kaplan Company, 2013.

Ballast, David Kent. *Interior Construction & Detailing for Designers & Architects*, 6th Ed. PPI a Kaplan Company, 2019.

Bell, Victoria Ballard. *Materials for Design*. Princeton Architectural Press, 2006.

Bingelli, Corky. *Materials for Interior Environments*, 2nd Ed. Wiley, 2013.

Borden, Gail Peter and Michael Meredith. *Matter: Material Processes in Architectural Production*. Routledge, 2012.

Brownell, Blaine. *Transmaterial: A Catalog of Materials That Redefine our Physical Environ-*

- ment. Princeton Architectural Press, 2006.
- Brownell, Blaine. *Transmaterial Next: A Catalog of Materials That Redefine our Future*. Princeton Architectural Press, 2006.
- Dent, Andrew H. and Leslie Sher. *Material Innovation: Product Design*. Thames & Hudson, 2014.
- Dent, Andrew H. and Leslie Sher. *Material Innovation: Architecture*. Thames & Hudson, 2014.
- Ermann, Michael. *Architectural Acoustics Illustrated*. Wiley, 2015.
- Gibbs, Nick. *The Real Wood Bible: The Complete Illustrated Guide to Choosing and Using 100 Decorative Woods*. Firefly Books, 2012.
- Godsey, Lisa. *Interior Design Materials and Specifications*, 3rd Ed. Fairchild Books, 2017.
- International Code Council. *International Building Code 2018*. International Code Council, 2018.
- Kennon, Katherine E. and Sharon K. Harmon. *The Codes Guidebook for Interiors*, 7th Ed. Wiley, 2018.
- King, Bruce. *The New Carbon Architecture: Building to Cool the Climate*. New Society Publishers, 2017.
- Kolarevic, Branko and Kevin Klinger. *Manufacturing Material Effects: Rethinking Design and Making in Architecture*. Routledge, 2008.
- Lefteri, Chris. *Plastic Materials for Inspirational Design*. RotoVision SA, 2001.
- Leppo, Holly Williams. *LEED PREP: What You Really Need to Know to Pass the LEED AP Interior Design & Construction Exam*. Professional Publications, Inc., 2009.
- Lupton, Ellen. *Skin: Surface, Substance, and Design*. Princeton Architectural Press, 2002.
- Postell, Jim and Nancy Gesimondo. *Materiality and Interior Construction*, Wiley, 2011.
- Reed, Ron. *Color + Design: Transforming Interior Space*, 2nd Ed. Fairchild Books, 2017.
- Reznikoff, S. C. *Interior Graphic and Design Standards*. Watson-Guptill, 1986.
- Riggs, Rosemary J. *Materials and Components of Interior Design*, 3rd Ed. Prentice Hall, 1992.
- Smith, Ronald C. *Materials of Construction*, 4th Ed. McGraw-Hill, 1988.
- Thallon, Rob. *Graphic Guide to Interior Details for Builders and Designers*. The Taunton Press, 1996.
- Thompson, Rob and Martin Thompson. *The Materials Sourcebook for Design Professionals*. Thames & Hudson, 2017.
- Thompson, Rob. *Manufacturing Processes for Design Professionals*. Thames & Hudson, 2007.
- Tucker, Lisa M. *Designing Sustainable Residential and Commercial Interiors: Applying Concepts and Practices*. Fairchild Books, 2014.
- Tucker, Lisa M. *International Building Codes and Guidelines for Interior Design*. Fairchild Books, 2018.
- Wiewiorra, Carsten. *Materials and Finishings: Construction and Design Manual*. DOM Publishers, 2020.
- Winchip, Susan M. *Sustainable Design for Interior Environments*, 2nd Ed. Fairchild Books, 2011.

IMAGE CREDITS

CHAPTER 01

Fig. 01/01 – Monkey Business Images, Atrium lobby and stairs in a modern office building. Shutterstock® #1133218124.

Fig. 01/02 – Litracon®, Light-transmitting concrete. www.litracon.hu.

Fig. 01/03 – pio3, BERLIN - JUNE 3, 2013: Tourists in front of Babylonian city wall in Pergamon museum. It is the most visited in Berlin with more than 1.5 million visitors per year. Shutterstock® #182077328.

Fig. 01/04 – archer10(Dennis), Switzerland-01861 - St Maurice. Licensed under CC BY-2.0.

Fig. 01/05 – goosmurf, Rubber tree. Licensed under CC BY-2.0.

Fig. 01/06 – josefkubes, Old brown vintage bakelite radio on wooden background. Shutterstock® #649535989.

Fig. 01/07 – MAXSHOT.PL, Black wooden chair, isolated. Antique wood chairs on white

background. Shutterstock® #1131419399.

Fig. 01/08 – photo026, modern white fiber meridienne. 123RF® #32803754.

Fig. 01/09 – Yuri Zap, Three LED (light-emitting diode) on the circuit board; focus on diodes. Shutterstock® #91083266.

Fig. 01/10 – Kutay Guler, Compression, tension, and shear forces acting on a simple object.

Fig. 01/11 – gilaxia, Pumping concrete over rebar mesh. iStock® #1272942395.

Fig. 01/12 – Foamed aluminum features tiny gas bubbles. Shutterstock® #1257678487.

Fig. 01/13 – Angela Schmeidel Randall, Mold. Licensed under CC BY-2.0.

Fig. 01/14 – tiraspr, The roof of the Hotel De Frontenac in Quebec City, Canada. 123RF® #83708783.

CHAPTER 02

Fig. 02/01 – Hazem M. Kamal, highly detailed needlework wool fabric, close up wool texture background. Shutterstock® #639881140.

Fig. 02/02 – davidwilson1949, 20130525 05 Farnsworth House. Licensed under CC BY-2.0.

Fig. 02/03 – agallud, Pie unite marsella. Licensed under CC BY-SA 2.0.

Fig. 02/04 – focusc, Fallingwater. Licensed under CC BY 2.0.

Fig. 02/05 – blueskyline, Car seat. iStock® #618721024.

Fig. 02/06 – Kutay Guler, Examples of transparent, translucent, and tinted glass.

Fig. 02/07 – Surrey Nanosystems Ltd., Vantablack®. <https://www.surreynanosystems.com>

Fig. 02/08 – Alex from the Rock, Silhouette of business group discussing new plan. Team meeting on the couch. Big open space office. Five people. Intentional sun glare. Shutterstock® #653330653.

Fig. 02/09 – Kutay Guler, Sunlight casting shadows.

Fig. 02/10 – Kutay Guler, Artificial light casting shadows.

Fig. 02/11 – Zamurovic Brothers, Pink bananas on pink background. Minimal style. Flat lay. Shutterstock® #531352276.

Fig. 02/12 – martinhoward, Television Face Close-up. Licensed under CC BY-2.0.

Fig. 02/13 – XXLPhoto, Several dyed plastic polymer granulates in laboratory. Shutterstock® #229804894.

Fig. 02/14a – fipphoto, Luxury and fashionable brand new interior of cloth store. Shutterstock® #193988375.

Fig. 02/14b – StorKiss, Lighting on modern ceiling ,Modern Style. Shutterstock® #591879872.

Fig. 02/14c – haveeseen, Futuristic armchair in red interior. Shutterstock® #28399093.

Fig. 02/14d – August_0802, High fashion design for lounge interior. Shutterstock® #777623641.

Fig. 02/15 – Kutay Guler, Examples of relief receiving light from various angles.

Fig. 02/16 – Ryan DeBerardinis, Wooden Swirls Organic Background Texture. Shutterstock® #114087232.

Fig. 02/17 – lasagnaforone, Hand Drawn Seamless Pattern stock illustration. iStock® #1177884934.

Fig. 02/18 – C4289N, Walkway with the roof in the garden. Shutterstock® #643940401.

Fig. 02/19 – Philipp Shuruev, Pastel interior in classic style with soft armchairs and lamps. Shutterstock® #631879034.

Fig. 02/20 – Wassily Kandinsky, Composition VIII (1923). Public domain.

Fig. 02/21 – US Embassy Canada, Transporting the molten metal to the casting area. Licensed under CC PDM 1.0.

CHAPTER 03

Fig. 03/01 – zhu difeng, Modern kitchen and busy chefs in hotel. Shutterstock® #273413579.

- Fig. 03/02 – North Charleston, Effectiveness of a home sprinkler system. Licensed under CC BY-SA 2.0.
- Fig. 03/03 – monkeybusinessimages, Busy Nurse’s Station in Modern Hospital. iStock® #504831370.
- Fig. 03/04 – Unknown author, President Bush signs the Americans with Disabilities Act into law. Public Domain.
- Fig. 03/05 – reddees, Closeup of modern empty Wheelchair for disabled patient in indoors with shades on carpet. Shutterstock® #1261110655.
- Fig. 03/06 – shank_ali, Stairlift. iStock® #106598323.
- Fig. 03/07 – Jaap Driest, _JDR2382. Licensed under CC PDM 1.0.
- Fig. 03/08 – JAK83, A NEMA 5-15 (120V/15A) duplex receptacle or socket. Public domain.
- Fig. 03/09 – Chim, Indoor air quality problem PM 2.5 measurement. environmental problem in Bangkok with high PM (fine particulate matter) 2.5 air bound pollution. Shutterstock® #1299047773.
- Fig. 03/10 – Rubber Dragon, Roller Varnishing Floor. Licensed under CC BY-SA 2.0.
- Fig. 03/11 – Ileeerogers, Dirty Bathroom Grouting. iStock® #487831037.
- Fig. 03/12 – Westland Environmental Ltd., Asbestos close-up. Shutterstock® #691857409.
- Fig. 03/13 – SenseiAlan, 1939 White Lead Paint Advertisement Better Homes & Gardens October 1939. Licensed under CC BY 2.0.
- Fig. 03/14 – areporter, Old painted board vintage. Shutterstock® #359182628.
- Fig. 03/15 – MatthiasKabel, The cross section of a particle board. Licensed under CC BY-SA 3.0.
- Fig. 03/16 – amenic181, Man holding lit and smoking cigarette between fingers and working on a laptop computer. iStock® #820820886.
- Fig. 03/17 – Kutay Guler, Frequency distribution of various sounds.
- Fig. 03/18 – alexdecarvalho, Carnival Center for the Performing Arts. Licensed under CC BY 2.0.
- Fig. 03/19 – Trevor Cox, Measuring a diffuser in an anechoic chamber. Licensed under CC BY-SA 3.0.
- Fig. 03/20a – Krzysztof12, White and yellow mineral wool. iStock® #1162315423.
- Fig. 03/20b – Tech109, Acoustic Ceiling Tile Texture 1. Licensed under CC BY 2.0.
- Fig. 03/20c – lucky_spark, Soundproofing decorative panels close-up made of pressed tree fibers. iStock® #939164580.
- Fig. 03/20d – BanksPhotos, Recycled Blue Jean Denim Insulation with Wall Stud. iStock® #184856976.
- Fig. 03/21 – mysondanube, Perforated wooden surface background. iStock® #517795947.
- Fig. 03/22 – FarukUlay, Velvet curtain. iStock® #172795817.
- Fig. 03/23 – Kutay Guler, Sound transmission class (STC) for various gypsum board assemblies.
- Fig. 03/24 – WichienTep, Vibration Damper in Use. iStock® #803050668.
- Fig. 03/25 – Kutay Guler, Flanking Illustration.

CHAPTER 04

- Fig. 04/01 – Soren.harward, Robert Smithson, Spiral Jetty from atop Rozel Point, in mid-April 2005. Licensed under CC BY-SA 2.0.
- Fig. 04/02 – Pen Waggener, Bald eagle. Licensed under CC BY 2.0.
- Fig. 04/03 – Operação Hymenaea, Julho-2016, Deforestation in the state of Maranhão. Licensed under CC BY 2.0.
- Fig. 04/04 – Daniel Majak, Cork/bark getting ready for processing after the harvesting of the cork tree. It will soon be wine corks and other products. Shutterstock® #1076336789.
- Fig. 04/05 – Tõnu Mauring, Passive house

conference 2006. Licensed under CC BY 2.0.

Fig. 04/06 – Dark Dwarf, Sticky Burrs on a Burdock Plant. Licensed under CC BY-ND 2.0.

Fig. 04/07 – verchmarco, Container filled with collected empty PET bottles, cans and plastic cups at Tomorrowland Festival 2019. Licensed under CC BY 2.0.

Fig. 04/08 – Plant pests and diseases, DSC05657 composting. Licensed under CC0 1.0.

Fig. 04/09 – juhansonin, Start your cookin’ engines. Licensed under CC BY 2.0.

Fig. 04/10 – Tim Hursley, Seaton Hall.

Fig. 04/11 – vgajic, Cleaning And Disinfecting Office. iStock® #1215724939.

CHAPTER 05

Fig. 05/01 – buteo, Ancient Cave Paintings in Patagonia. Shutterstock® #12537205.

Fig. 05/02 – Pixelmaniac pictures, Titanium dioxide powder dispersing in water. Licensed under CC0 1.0.

Fig. 05/03 – Irina Krolevetc, Stone wall painted with white paint, background, texture. iStock® #950991194.

Fig. 05/04 – Picture Partners, Pieces of Gum arabic on white background. Shutterstock® #470512106.

Fig. 05/05 – Photographee.eu, Green armchair against blue wall with silver painting in living room interior with plants. Shutterstock® #1071499427.

Fig. 05/06 – Kutay Guler, Five levels of sheen in paint applications.

Fig. 05/07 – Lyudmila Mikhailovskaya, Painting of furniture. Shutterstock® #601046012.

Fig. 05/08 – Elade53, Gypsum: Lubin, Poland. Public domain.

Fig. 05/09 – Esprit de sel, (almost) clean corridor. Licensed under CC BY-ND 2.0.

Fig. 05/10 – Kinek00, Newly installed WC concealed frame for wall-mounted toilet, built in plasterboard, in the bathroom. iStock® #1300496850.

Fig. 05/11 – oracul, Lath. Background. iStock® #470350908.

Fig. 05/12 – Kutay Guler, Five levels of gypsum board application.

Fig. 05/13 – Joe_Potato, Concrete, stucco, chicken wire wall repair. Vertical. iStock® #480263882.

Fig. 05/14 – georgeclerk, Close up of a traditional, intricate Georgian cornice moulding on the interior of an Edinburgh flat. iStock® #166022788.

Fig. 05/15 – Georgia National Guard, Applying drywall joint compound. Licensed under CC BY 2.0.

Fig. 05/16 – RightFramePhotoVideo, Close up of painter hands with gloves painting the wall edge by door frame. iStock® #1221306239.

Fig. 05/17 – PeterG, A custom faux finished wall surrounds a luxury jetted tub. Shutterstock® #6883447.

Fig. 05/18 – Unknown, Flock Wallpaper. Shutterstock® #139743388.

Fig. 05/19 – Noble Nature, Background with Cashmir motif blue green and ochre. iStock® #1132789274.

Fig. 05/20 – Kutay Guler, Most commonly used International Wallcovering Symbols.

Fig. 05/21 – SMedia, Natural dark gray grasscloth wallpaper texture. iStock® #1251976100.

Fig. 05/22 – Marko Poplasen, Apartment interior. Shutterstock® #233965519.

Fig. 05/23 – Nadir Keklik, Man brushing glue paste onto wallpaper on desk. Shutterstock® #1329341237.

CHAPTER 06

Fig. 06/01 – Pavel Ilyukhin, Pantheon in Rome, inside view, Italy. Shutterstock® #232816723.

Fig. 06/02 – Doug Waldron, Portland Cement Factory (149). Licensed under CC BY-SA 2.0.

- Fig. 06/03 – Achim Hering, Robert Moses secondary efflorescence 2. Licensed under CC BY 3.0.
- Fig. 06/04 – Piotr Wytrazek, Electronic hygrometer for taking measurements. Accessories for determining the moisture content of building materials. iStock® #1313538624.
- Fig. 06/05 – elenaleonova, Warm water floor, pouring concrete floor. iStock® #478393260.
- Fig. 06/06 – cogdogblog, A good day to pour concrete. Licensed under CCO 1.0.
- Fig. 06/07 – Vladyslav Horoshevych, Concrete floor grinding machine, concrete floor repair. iStock® #1288489062.
- Fig. 06/08 – Charles Ellinwood, Board-formed concrete background in color landscape format. iStock® #1252574876.
- Fig. 06/09a – suksao999, Texture for the pattern of the marble. iStock® #520002635.
- Fig. 06/09b – mollypix, Concrete pebble textured abstract backgrounds terrazzo. iStock® #1312617004.
- Fig. 06/09c – StockImages_AT, Very old terrazzo tile floor. iStock® #585283340.
- Fig. 06/09d – Supersmario, Marble texture background. iStock® #1137670325.
- Fig. 06/10 – Kondratev Alexey, View of the Cathedral Santa Maria del Fiore at sunset. Florence, Italy. Shutterstock® #602115368.
- Fig. 06/11 – Eug Png, San Francisco 2013, external view of Xanadù art gallery designed by the great architect Frank Lloyd Wright. Shutterstock® #715257187.
- Fig. 06/12 – Keri Delaney, Stacks of old red brick pavers piled high and deep show their wear: Cracks, chips and mortar add character to the reclaimed construction materials. Shutterstock® #1081386356.
- Fig. 06/13 – Kutay Guler, Various brick bonding techniques.
- Fig. 06/14 – Di Studio, Brown retro sofa over white brick wall. Shutterstock® #647634883.
- Fig. 06/15 – Archaeology Scotland, A house from the now abandoned Neolithic site of Skara Brae. Licensed under CC BY-SA 4.0.
- Fig. 06/16 – palmetto, Marble inlay. Shutterstock® #601578296.
- Fig. 06/17 – rich701, 20-17b Vinalhaven, Maine 1936 Pink Granite Quarry. Licensed under CC BY 2.0.
- Fig. 06/18 – alekime, A block of stone is cutting. iStock® #158170529.
- Fig. 06/19 – Z22, Rock of Ages granite quarry in Barre Vermont. Licensed under CC BY-SA 3.0.
- Fig. 06/20 – draganab, Onyx wall, back lit, close-up. iStock® #1190009883.
- Fig. 06/21 – Jennifer Kosig, Abstract fluid background, black, blue and white liquid, horizontal. iStock® #1153641342.
- Fig. 06/22 – Jennifer Kosig, Abstract marble background, blue fluid. iStock® #1151361936.
- Fig. 06/23 – Kutay Guler, Four granite pattern matching techniques.
- Fig. 06/24a – WeStudio, Background of Modern Slate stone Brick Wall Surfaced for design. Shutterstock® #1014049126.
- Fig. 06/24b – itmpa, Balvaired Castle. Licensed under CC BY-SA 2.0.
- Fig. 06/25 – Gajus, Man pressing an ornamental tile into a glue on a wall with gloved hands in a DIY concept. Shutterstock® #348725168.
- Fig. 06/26 – mooglepuff, Ripe lemons on a stone granite benchtop kitchen background. iStock® #687447458.

CHAPTER 07

- Fig. 07/01 – treehouse1977, Winter oak reflections 02. Licensed under CC BY-SA 2.0.
- Fig. 07/02 – Dudarev Mikhail, Stumps on the valley caused by deforestation and slash and burn type of agriculture of Madagascar. Shutterstock® #367199342.
- Fig. 07/03 – Olena Vysokolian, Heartwood texture background, cut log. Shutterstock®

- #1349670035.
- Fig. 07/04 – Wuttichok Panichiarapun, Macro Ormosia wood texture, Afzelia xylocarpa (Kurz) Craib, LEGUMINOSAE-CAE-SALPINIOIDEAE (FABACEAE). Shutterstock® #391031545.
- Fig. 07/05 – Julie Clopper, A closeup of spalted maple, a fungal growth. Shutterstock® #355600658.
- Fig. 07/06 – Kutay Guler, Radial, Tangential, and Longitudinal dimensions of lumber, warping, and cupping.
- Fig. 07/07 – Kutay Guler, Lumber sawing methods.
- Fig. 07/08 – Sergii Petruk, Modern woodworking technology, automatic sawmill, close-up. iStock® #1202331165.
- Fig. 07/09 – roryrory, Peter Zumthor, Saint Benedict Chapel, 1985-88. Licensed under CC BY-SA 2.0.
- Fig. 07/10a – lunamarina, Blue swimming pool with teak wood flooring stripes summer vacation. Shutterstock® #77204545.
- Fig. 07/10b – pics721, Master bath with wood paneling. Shutterstock® #34084690.
- Fig. 07/10c – tab62, Wooden oak staircase with carpet steps and white molding. Shutterstock® #105972977.
- Fig. 07/10d – Maytee Bamrungrajhirun, Modern long wooden chair in front of grey wall. Shutterstock® #779545996.
- Fig. 07/11 – Fernando Moital, Descortçamento. Licensed under CC BY 2.0.
- Fig. 07/12a – smereka, A fragment of a wooden panel hardwood, walnut. Shutterstock® #1272070105.
- Fig. 07/12b – Guiyuan Chen, Walnut natural texture. Wood plank texture background. Shutterstock® #1271308375.
- Fig. 07/13 – PopFoto, Natural hickory wooden texture. Shutterstock® #658970167.
- Fig. 07/14 – Nightman165, High quality maple wood grain texture. Shutterstock® #60168691.
- Fig. 07/15 – otophoto, Oak texture parquet background. Shutterstock® #556965634.
- Fig. 07/16 – billnoll, White ash wood. iStock® #182491367.
- Fig. 07/17 – wk1003mike, Wood texture. Wood texture for design and decoration. Shutterstock® #561173923.
- Fig. 07/18 – Pawel Hankus, Seamless texture - wood - maple 01 - seamless - tile able. Shutterstock® #402597067.
- Fig. 07/19 – Unru Elena, Wood texture Abstract wood texture for background image. Shutterstock® #127446509.
- Fig. 07/20 – emrah_oztas, Wood grain textured. iStock® #116282438.
- Fig. 07/21 – HP Productions, Cherry wood closeup. Shutterstock® #216978232.
- Fig. 07/22 – inxti, Nice large image of polished wood texture. Shutterstock® #57311761.
- Fig. 07/23 – Efetova Anna, New fresh wooden surface with bright texture on it, pine pattern. Shutterstock® #375588814.
- Fig. 07/24 – billnoll, Douglas Fir wood texture. iStock® #172423355.
- Fig. 07/25 – NNehring, Western red cedar wood, Thuja plicata. iStock® #115910060.
- Fig. 07/26 – billnoll, Natural Zebrawood texture. iStock® #182796093.
- Fig. 07/27 – Johnny Adolphson, Rustic aged barn wood background. Shutterstock® #135976394.
- Fig. 07/28 – Norm Stephens, Wood Kiln at the Begley Lumber Company. Licensed under CC PDM 1.0.
- Fig. 07/29 – Jatuporn Chainiramitkul, Damaged parquet floor because of humidity and moisture, bending and come out, image captured by smartphone. Shutterstock® #1223744728.
- Fig. 07/30 – Kutay Guler, Wood joinery types.
- Fig. 07/31 – EasyBuy4u, Treated wood. iStock® #184293184.
- Fig. 07/32 – Ralph Geite, Preparation of an

- old wooden board by grinding with a hand sanding block. iStock® #1081914176.
- Fig. 07/33 – Benjamin Clapp, Hand holding brush shows how to apply brown mahogany stain to raw oak wood furniture or floor. Shutterstock® #1075597655.
- Fig. 07/34 – Levent Konuk, Wood floor polishing maintenance work by grinding machine. Shutterstock® #278505167.
- Fig. 07/35 – Kutay Guler, Veneer slicing methods.
- Fig. 07/36 – Angelo Sarnacchiaro, Background texture of dark wood, wenge. Shutterstock® #210943123.
- Fig. 07/37 – Kutay Guler, Four veneer pattern matching techniques.
- Fig. 07/38 – Wanessa_p, Typical home improvement problem. Miserable, Chipped and damaged skin of wooden veneer door. Cause by moisture and timeworn usage. Shutterstock® #1155246448.
- Fig. 07/39 – D-Kuru, Particle board close up-vertical-f22 PNr°0100. Licensed under CC BY-SA 3.0.
- Fig. 07/40 – The Marmot, Bent Plywood. Licensed under CC BY 2.0.
- Fig. 07/41 – Photographee.eu, Contemporary industrial interior for modern young designer. Shutterstock® #335117000.
- Fig. 07/42 – Dave Dugdale, Apple Valley Road Lyons Colorado Bridge. Licensed under CC BY-SA 2.0.
- Fig. 07/43 – Associated Fabrication, cirrus01_4. Licensed under CC BY 2.0.
- CHAPTER 08**
- Fig. 08/01 – Onohej Zlatove, Moldavite No.3. Licensed under CC BY-SA 4.0.
- Fig. 08/02 – Kutay Guler, Greenhouse effect illustration.
- Fig. 08/03 – James Cridland, 100 green bottles. Licensed under CC BY 2.0.
- Fig. 08/04 – Nadia Abdullah, A close-up of broken pieces of tempered glass. Shutterstock® #650297899.
- Fig. 08/05 – iampicnote, Structural glass curving. iStock® #1199795406.
- Fig. 08/06 – WangAnQi, Modern Glass Staircase Silhouette of walking People in Shanghai, China. iStock® #835392106.
- Fig. 08/07 – imamember, Closeup broken glass, broken reinforced window background, copy space. iStock® #478345808.
- Fig. 08/08 – Lepro, Clear glass with green scenery in background. iStock® #96904670.
- Fig. 08/09 – Grand Warszawski, Train on the railroad tracks during sunset. iStock® #1196463286.
- Fig. 08/10 – babyrhino, Glass Film Design. frosted film glass sticker cut in pattern, Modern office, Concept. Privacy in work place, Manager room. Glass wall idea for interior. iStock® #1313079792.
- Fig. 08/11 – pedrosimoes7, Comics glass reflection. Licensed under CC BY 2.0.
- Fig. 08/12 – Kutay Guler, The various edge treatment methods used for panel and sheet products.
- Fig. 08/13 – Mikhail Gnatkovskiy, Metal mount with fasteners elements of spider glass system for glass walls. Shutterstock® #1009759501.
- Fig. 08/14 – Robert Knapp, Old, dry and cracked window sealing peeling off between the glass and the metal frame. iStock® #1264674611.
- Fig. 08/15 – Kuprynenko Andrii, Shower with glass partition in bright white bathroom. Simple and elegant interior, 3D render. Shutterstock® #367452134.
- Fig. 08/16 – chinahbzyg, Ceramic toilet semi-finished products in the kiln, in a ceramic enterprise. Shutterstock® #174534077.
- Fig. 08/17 – R Skilton, Interior at Alhambra, Spain. Shutterstock® #117706282.
- Fig. 08/18 – Bevis Chin, Park Guell. Licensed

under CC BY-ND 2.0.

Fig. 08/19 – nontthepcool, Orange marble floor texture pattern background. Shutterstock® #1338988526.

Fig. 08/20 – Puripat penpun, Old blue tile wall. iStock® #975066534.

Fig. 08/21 – olegbreslavtsev, Four clean white towels on holder in hotel bathroom with textured black wall. Modern minimal style. iStock® #1064350620.

Fig. 08/22 – Ozgur Yaman, Wet floor sign. iStock® #937685688.

Fig. 08/23 – narvikk, Professional tiler installing new tiles on the floor. iStock® #1319403507, #1319403503, #1319403502.

Fig. 08/24 – Alphotographic, Yellow square and blue dot tile background. iStock® #1218931632.

Fig. 08/25 – Horsche, Man applying blue grout to white tiles. iStock® #613788600.

CHAPTER 09

Fig. 09/01 – Chilanga Cement, Looms. Licensed under CC BY-SA 2.0.

Fig. 09/02 – N/A, Polyester clothing label. Shutterstock® #795872566.

Fig. 09/03 – Kutay Guler, Common fiber cross sections.

Fig. 09/04 – Kutay Guler, Yarn construction – based on Elkágyé, Thread made from two threads plied together, each consisting of three yarns. Public domain.

Fig. 09/05 – t-mizo, Cotton plant (Matsudo, Chiba, Japan). Licensed under CC BY 2.0.

Fig. 09/06 – Marta Maziar, Natural jute twine roll, burlap on black background. Supplies and tools for handmade hobby leisure close-up. Shutterstock® #1019058865.

Fig. 09/07 – Baishiya_, Silkworm. Licensed under CC BY-SA 2.0.

Fig. 09/08 – buteo, A heard of sheep in Patagonia. Shutterstock® #42158764.

Fig. 09/09 – Kittibowornphatnon, Process of rolling plastic fiber for plastic sack. Shutterstock® #621545768.

Fig. 09/10 – TLaoPhotography, Carbon aramid kevlar background. Shutterstock® #352513007.

Fig. 09/11 – Detlef Schobert, Basel, Schaulager, Metal Mesh. Licensed under CC BY-ND 2.0.

Fig. 09/12 – Kutay Guler, Weave types.

Fig. 09/13 – N/A, DMM 29263ab Jacquard-webstuhl. Licensed under CC BY 3.0.

Fig. 09/14 – dutourdumonde, Natural wool dyeing in a carpet factory, Nepal. iStock® #543352720.

Fig. 09/15 – sunwards, Closeup downward arrow lines knitted texture. iStock® #1212713613, #1256744867, #1199069389, #1197079705.

Fig. 09/16 – r.classen, Lotus effect with water drops on black textile. Shutterstock® #108423431.

Fig. 09/17 – Kutay Guler, Sample textile information card.

Fig. 09/18a – russaquarius, Lint balls/fuzz balls on fabric. iStock® #519654670.

Fig. 09/18b – N/A, Fraying fabric. Public domain.

Fig. 09/19 – www.davidrosenphotography.com, Above Fez tannery. Licensed under CC BY 2.0.

Fig. 09/20 – Adil Abdrakhmanov, Brown damaged artificial leather texture background. Bad quality artificial leather, weathered leather. iStock® #1288044356.

Fig. 09/21 – Hitdelight, Natural brown leather texture background. Abstract vintage cow skin backdrop design. Shutterstock® #114140692.

Fig. 09/22 – fmajor, A tailor is cutting leather. iStock® #478407202.

Fig. 09/23 – kucko, Sample - a good quality leather in various colors. iStock® #453550893.

Fig. 09/24 – Rawiz, Interior of carpet floor in

the office. Shutterstock® #569416768.

Fig. 09/25 – pastorscott, Luxury lobby. iStock® #157685017.

Fig. 09/26 – Kutay Guler, Tufted pile types.

Fig. 09/27 – Pholon, Carpet texture. Shutterstock® #262943783.

Fig. 09/28 – Erick Nielsen Photography, Where old carpet meets old carpet. Licensed under CC BY-ND 2.0.

Fig. 09/29 – Andy Dean Photography, Pulled Back Carpet and Padding in Room of House. Shutterstock® #491386858.

Fig. 09/30 – Gordon Ball LRPS, Open plan office lit by natural and artificial light. Shutterstock® #10887529.

Fig. 09/31 – Ninara, Persian Carpet, Ravar, Kerman Province. Licensed under CC BY 2.0.

Fig. 09/32 – Bill Oxford, Installing carpet at home. iStock® #639282100.

Fig. 09/33 – fullvalue, Gluing carpeting down on concrete floor. iStock® #172730598.

Fig. 09/34 – Offscreen, Installation of carpet, the installer does the seams. Shutterstock® #115835425.

Fig. 09/35 – Noobiel, Laminate and tile transition with aluminium profile. Shutterstock® #440176615.

Fig. 09/36 – Kutay Guler, Sample seaming diagram.

Fig. 09/37 – Kutay Guler, The individual constituents of a furniture piece.

Fig. 09/38 – N/A, Polyurethane foam. Shutterstock® #1061026994.

Fig. 09/39 – Sebastian ter Burg, Chesterfield four seater sofa. Licensed under CC BY 2.0.

Fig. 09/40 – Kutay Guler, Common pattern alignment methods for upholstery.

Fig. 09/41 – Juris Kraulis, Antique Biedermeier style sofa with authentic fabric and wood carving before and after restoration, in a single photo. Shutterstock® #726372607.

Fig. 09/42 – Vineyard Perspective, Shuttered window with one pane open letting through

rays of light and a faint image of autumn leaves outside. Shutterstock® #757019359.

Fig. 09/43 – Tunatura, Window roller, duo system day and night, detail. Shutterstock® #1277900365.

Fig. 09/44 – Kutay Guler, Pleating types.

Fig. 09/45 – Svetlana Vasilyeva, Luxurious lace curtains with frill and pelmet. iStock® #1194130844.

CHAPTER 10

Fig. 10/01 – SuperPuay, Close up image of textured hammered brass in rustic style. Shutterstock® #1370583458.

Fig. 10/02 – SixTwo Point of View, Gateway Arch St Louis. Licensed under CC BY-ND 2.0.

Fig. 10/03 – D3j4vu, Stainless-steel-mild-steel. Licensed under CC BY-SA 3.0.

Fig. 10/04 – SJ Pinkney, Statue of Liberty, New York. Licensed under CC BY 2.0.

Fig. 10/05 – ky0nch3ng, Forging hot iron. Licensed under CCO 1.0.

Fig. 10/06 – Phuchit, The table spindle tilt type 5-axis CNC milling machine. iStock® #948602592.

Fig. 10/07 – Ake Dynamic, Close-up Welded Threaded Lug on Metal Frame at Workshop. iStock® #1286801758.

Fig. 10/08 – V_Sot_Visual_Content, Steel structure of the bridge on bolted and riveted joints. Shutterstock® #1334228015.

Fig. 10/09 – Detlef Schobert, Vaduz, Belvedere, Wall Cladding. Licensed under CC BY-ND 2.0.

Fig. 10/10 – AlexWang_AU, Oven settings panel closeup. iStock® #1312907026.

Fig. 10/11 – ELENAPHOTOS, Prague subway. iStock® #508789937.

Fig. 10/12 – AmaliaL, Hoba majestic prehistoric 60 ton largest meteorite known in Earth. Landmark located at Grootfontein in Namibia, Africa. Shutterstock® #1049269904.

Fig. 10/13 – Maxime Guilbot, Eiffel Tower Close-up. Licensed under CC BY 2.0.

Fig. 10/14 – David Dixon, Bessemer Converter, Kelham Island Museum. Licensed under CC BY-SA 2.0.

Fig. 10/15 – ballykdy, Steel roof truss with zinc gutter and roof insulation, black and white. Shutterstock® #289866224.

Fig. 10/16 – SimplyCreativePhotography, Green coated reinforcing rods. iStock® #517928722.

Fig. 10/17 – seier+seier, tegnestuen vandkunken, IKEA, Gentofte, Copenhagen 1995. Licensed under CC BY 2.0.

Fig. 10/18 – A_Lein, University of Economics in Vienna. iStock® #462402361.

Fig. 10/19 – Ra Boe, Red mud dump close to Stade, Germany. Licensed under CC BY-SA 3.0.

Fig. 10/20 – Kutay Guler, Folding, corrugating, and ribbing increases strength of the sheet metal.

Fig. 10/21 – Goncharovaia, Contemporary architecture. Modern building facade of sports venue with perforated and polished aluminium plates. Texture of metal structures close-up, steel background. Abstract technology. Shutterstock® #1303317253.

Fig. 10/22 – N/A, Polished bronze at main gate, Duomo di Milano. Licensed under CC BY 2.0.

Fig. 10/23 – Maryna Andriichenko, Woman washing hands under water tap. Self care and hygiene. Close up of female hand. iStock® #1225823497.

Fig. 10/24 – Jebulon, The mosaics of the dome of the Cappella Chigi, by Luigi da Pace (1516) after cartoons by Raphaël, church Santa Maria del Popolo, Rome, Italy. Unique mosaics due to Raphaël. Public domain.

Fig. 10/25 – TheSeafarer, Pressed tin ceiling Giddings TX Chamber of Commerce. Licensed under CC BY 2.0.

Fig. 10/26 – Philip Openshaw, Metallic cladding on modern industrial building. Shutterstock® #658965985.

CHAPTER 11

Fig. 11/01 – N/A, Celluloid film. Shutterstock® #749854042.

Fig. 11/02 – mbrphoto, Colourful glass samples - kitchen splashback samples. Shutterstock® #1249843873.

Fig. 11/03 – Ali Cobanoglu, A scrap heap of plastics in Turkey. iStock® #1312533280.

Fig. 11/04 – Dirk Wahn, Microplastics in the Mediterranean. iStock® #1263568234.

Fig. 11/05 – Kutay Guler, Resin identification codes.

Fig. 11/06 – Brentano Fabrics, Brentano - Sputnik, Portfolio Collection Fall 2011. Licensed under CC PDM 1.0.

Fig. 11/07 – VDCM image, VDCM002 shark in the ocean aquarium. iStock® #1050659708.

Fig. 11/08 – N/A, Polycarbonate panels. Public domain.

Fig. 11/09 – photovs, Male builder measuring plastic pipes with new home construction in hot and cold blue and red PEX pipe layout in pipes and exposed beams. iStock® #1231879659.

Fig. 11/10 – R/DV/RS, Abstracts - a smoke detector. Licensed under CC BY 2.0.

Fig. 11/11 – baona, Empty corridor in hospital operating room. iStock® #1124681231.

Fig. 11/12 – Olga Popova, The samples of collection natural linoleum. Shutterstock® #121160977.

Fig. 11/13 – Palatinate Stock, Man laying PVC-floor. Shutterstock® #582115630.

Fig. 11/14 – Luckeyman, CADZAND, NETHERLANDS - MARCH 14, 2018: Modern beach pavilion with mixed flooring. Shutterstock® #1106191376.

Fig. 11/15 – akhouseproject, Installing XPS foundation insulation. Licensed under CC BY 2.0.

Fig. 11/16 – Bernard Spragg, Fishing nets, Alaska. Licensed under CCO 1.0.

- Fig. 11/17 – faboi, Installation of fiberglass: worker manually realizes a component in glass fiber for automotive use. Creating a spoiler for cars using a mold. View from above. Shutterstock® #272025272.
- Fig. 11/18 – serts, Modern and big gym. iStock® #515836484.
- Fig. 11/19 – Rusty Clark ~ 100K Photos, Brevard County Landfill, Cocoa FL. Licensed under CC BY 2.0.
- Fig. 11/20 – BanksPhotos, Construction Worker Spraying Expandable Foam Insulation between Wall Studs. iStock® #185211977.
- Fig. 11/21 – N team, A cable under table legs on wheels at green epoxy floor. Shutterstock® #1050762770.
- Fig. 11/22 – Komsan meanglang, Melamine colorful, melamine sphere. Shutterstock® #661446760.
- Fig. 11/23 – Jordanhill School D&T Dept, The vacuum forming machine, forming the dome for Calvin's model. Licensed under CC BY 2.0.
- Fig. 11/24 – sergeyryzhov, Sectional frame of plastic insulating glass unit. iStock® #1312700858.
- Fig. 11/25 – jurvetson, Breaking the Mold. Licensed under CC BY 2.0.
- Fig. 11/26 – ake1150sb, Automatic PET/Plastic bottle blow moulding machine working in factory. iStock® #805233212.
- Fig. 11/27 – Sustainable Sanitation, Rotation moulding process. Licensed under CC BY 2.0.
- Fig. 11/28 – Prescott09, 3d printer closeup. iStock® #869465418.
- Fig. 11/29 – Iaremenko Sergii, Several layers of composite self-healing material. 3D illustration isolated on white background. Shutterstock® #494924185.
- Fig. 11/30 – Peter Sobolev, Metal honeycomb panel. Shutterstock® #136160294.
- Fig. 11/31 – COR_Wheels, Closeup of one of our real carbon wrapped step lips. When it comes to wheels, we can do it! Licensed under CC BY-SA 2.0.
- Fig. 11/32 – VanoVasaio, Master class for laying cork flooring, installation of a cork floor by a floating method, connection of a series of cork flooring. Shutterstock® #1072630871.
- Fig. 11/33 – Associated Fabrication, Olympic Athlete Village Benches. Licensed under CC BY 2.0.
- Fig. 11/34 – Papah-kah, Beautiful Quartz Stone Counter top in kitchen room with black wooden cabinet. Shutterstock® #1162687987.
- Fig. 11/35 – Vluce, Swatch of plastic counter top samples on a white background. Shutterstock® #69116572.
- Fig. 11/36 – Tim Bingham, Damaged Formica counter top. iStock® #1221709049.

CHAPTER 12

- Fig. 12/01 – N/A, Professionals around a table. Shutterstock® #1360296581.
- Fig. 12/02 – Kingsman Asset, Thailand - January 01,2007 : The interior of showroom Ceramic Materials display. Modern Ceramic tiles Display in the Luxury Shopping Mall. Shutterstock® #648115495.
- Fig. 12/03 – Darianne Conley, Material board, student work.
- Fig. 12/04 – Kutay Guler, Important points to measure for the interior space.
- Fig. 12/05 – Shutter Baby photo, Measuring tape, calculator, laser rangefinder and water level on plans. Shutterstock® #246668446.
- Fig. 12/06 – Kutay Guler, The example space used for the estimations.
- Fig. 12/07 – Onzeg, Close up image of rolls of paper. iStock® #854370760.
- Fig. 12/08 – BanksPhotos, Carpet Installer Joining Two Pieces with Seam Iron. iStock® #183836096.
- Fig. 12/09 – Kutay Guler, Criteria chart for material specification for interiors.
- Fig. 12/10 – gorica, Brand identity style font. iStock® #1141258188.

Fig. 12/11 – timltv, Beautiful modern glass railing for wooden staircase with wooden handrail. iStock® #1137905774.

Fig. 12/12 – Sergey Zavalnyuk, Warehouse of building materials. iStock® #94103751.

Fig. 12/13 – Tetiana Soares, ow. Child motor skills, creativity and imagination development game. Loneliness at self isolation period. iStock® #1217181629.

Fig. 12/14 – alvarez, 3D image of an environmentally friendly coworking office space. iStock® #1273978367.

Fig. 12/15 – AvigatorPhotographer, Aerial top view container ship at terminal seaport, Global business cargo freight ship import export logistic and transportation by container vessel ship company worldwide. iStock® #1276570868.

Fig. 12/16 – caoyu36, Tiles and backlight. iStock® #818358948.

INDEX

A

- Abrasion resistance – 219
 - ceramics – 128, 130, 131
 - paint – 67, 68
 - plastic – 190, 192
 - stone – 92
 - textile, 139, 141, 142, 143, 147
 - wallcovering – 78, 79
 - wood – 98,
- Access – 156, 172, 210, 222
- Accessibility – 33, 37, 38, 39, 224
- Acclimatizing – 98, 99, 108, 110, 115,
- Acoustic – 47, 48, 49, 50, 51, 52
 - concerns – 224, 225
 - engineer – 206
 - glass – 124, 127
 - gypsum – 74
 - performance – 41
 - textile – 145, 155, 162, 164
 - wallcovering - 79
- Acrylic – 17, 142, 183, 187, 188, 189, 198, 203
 - fiber – 142, 143
 - latex – 70, 133
 - paint – 70
 - resin – 110
 - sealer – 95
 - sunlight – 17
- Acrylonitrile butadiene styrene, ABS – 184, 200
- Adhesive – 45, 59, 60, 156, 157, 158, 172, 187, 196, 220, 223
- Aggregate – 82, 84, 86, 90, 201
- Air quality – 41, 42, 55, 62, 64
- Alloy – 167, 171, 175, 178, 184, 201
- Alkaline – 16, 83, 87, 140, 178, 179, 192
- Alkyd – 68, 70, 78
- Alpaca – 140
- Aluminum – 15, 19, 58, 88, 125, 167, 168, 170, 178, 179, 201
- American National Standards Institute, ANSI – 34
- American Association of Textile Chemists and Colorists, AATCC – 149
- American Society for Testing materials, ASTM International – 34, 35, 61

American Soc. of Heating, Refrigerating, and Air-Cond. Eng., ASHRAE – 41
Americans with Disabilities Act, ADA – 33, 38
Anchor – 95
Annealing
 glass – 123, 124
 metal – 169
Anodize – 173
Antimicrobial – 102, 103, 140, 180
Antimony – 193
Aramid – 143, 193
Architectural Barriers Act, ABA – 38
Area rug – 101, 140
Arsenic – 44, 62, 180
Asbestos – 43, 44, 62, 141, 191, 222
Asbestosis – 43
Association for Contract Textiles, ACT – 137
Attenuation – 50, 52, 124
Axminster weave – 153

B

Backing – 72, 74, 78, 81, 127, 130, 153, 155, 158
Backer board – 132
Backorder – 221
Bacteria – 59, 63, 95
Bakelite – 11, 183
Bamboo – 20, 56, 97, 140
Bark – 102, 151
Baseboard – 133, 203
Basecoat – 75
Batting
 acoustic – 48, 49, 52
 upholstery – 160
Ballpark estimate – 211
Bauxite – 178
Bedding – 162
Beech – 105, 109, 116
Bessemer conversion – 12, 175
Binder – 66, 68, 69, 73
Bioaccumulation – 55, 56
Biodegradable – 56, 59, 63, 139, 187, 192
Biodiversity – 97, 226
Biomagnification – 56
Bioplastic – 186, 187, 201
Birch – 105, 109, 116
Bisphenol A – 45, 185, 188, 193, 196
Blackout shade – 37, 164
Blast furnace – 174, 175
Bleach – 101, 103
Bleed – 75, 78, 101
Blind – 163, 179
Bolting – 171
Book matching
 veneer – 114
 stone – 93
Border – 20, 24, 156
Brick – 8, 9, 87, 88, 89
 bonding types – 88, 89
Broadloom – 155, 156, 158, 189, 215
Bronze – 167, 179, 180
Brushed – 23, 172, 176
Budget – 67, 162, 171, 211, 214, 219, 220, 221
Building code – 32, 33, 38, 72
Bullnose – 127
Burl – 98, 99, 114

C

Cabinetry – 60, 70, 118, 181
Calendering – 136, 198
Calcium
 carbonate – 9, 67, 71
 chloride – 84
 sulfate – 67
California Technical Bulletin – 37
California Air Resources Board – 45
Carbon
 dioxide, as CO₂ – 55, 56, 57, 60, 83, 97, 185
 monoxide, as CO – 37
 steel – 175
Carcinogen – 43, 44, 45, 46, 68, 77, 141, 180, 185

Carpet – 152, 153, 154
 backing – 140, 155
 construction – 152, 153, 154
 manufacturing – 142, 152
 installation – 155, 156, 157, 158
 pad – 140, 155, 157, 195
 recycling – 156, 157
 tile – 49, 60, 155, 156, 158
Carpet and Rug Institute, CRI – 156
Carpet Stewardship Program – 157
Casework – 8, 108, 116, 117, 189, 208
Cashmere – 141
Casters – 41, 60
Cedar – 107
Ceiling – 35, 43, 48, 52, 69, 71, 181, 203, 214, 218
 tile – 42, 52, 181
Cement – 9, 35, 73, 82, 83, 85, 133, 178,
Cementitious
 material – 86
 paste – 87
Ceramic – 9, 51, 95, 128, 129, 130, 131, 132, 134
Chain-of-custody – 97
Chatoyancy – 107
Cherry – 15, 104, 106, 112
Chestnut – 108
Chintz – 147
Chrome plating – 20, 173, 180, 181
Chromium – 44, 125, 150, 151, 173, 175, 180
 trivalent – 151, 180
 hexavalent – 44, 173, 180
Cigarette – 37
Cinder block – 87
Cladding – 20, 130, 168, 173, 181
Clay – 9, 67, 82, 87, 88, 128, 129, 130
Closed-loop – 55, 137, 226
Coefficient of Friction, COF – 38, 131, 132
Coffered ceiling – 48
Colorway – 146
Column cover – 176, 210
Composite – 8, 12, 115, 200, 201, 202
Compressed earth block, CEB – 88
Compression – 13, 14, 120, 176
Compression molding – 199
Concrete
 flooring – 51
 polished – 85, 87
 precast – 86
 reinforced – 14, 51, 83, 86, 176, 201
 translucent – 9
Concrete Masonry Unit, CMU – 87, 95
Coniferous – 107
Copper – 8, 15, 167, 168, 178, 179, 180
Cork – 56, 102, 103, 202
Cornice – 1164
Corrosion – 168, 172, 173, 175, 178, 181, 224
 galvanic – 168,
Corrugated – 176, 177
Construction type – 33, 34
Cost estimation – 211, 212, 213
Cotton – 77, 139, 140, 142, 143, 227
Cradle-to-Cradle, C2C – 62, 64
Crimped – 1139, 142, 143, 152
Cullet – 58
Cupping – 99, 219
Curtain – 37, 49, 50, 147, 164
Cyanide – 55, 180, 195

D

Daylight – 17, 24, 69, 162
Decibel, dB – 48
Deciduous – 97
Decking – 102, 107, 110, 118
 metal – 176
Deforestation – 11, 55, 56, 57, 71, 97, 140, 141, 187, 226
Delaminate – 81, 132, 155, 191, 205
Demolition – 44, 61, 77, 102, 167, 188, 207, 213
 waste – 71
Denier – 138, 139
Denim – 144
Diffuser – 49

Dimensional
lumber - 96, 100
stability - 78, 79, 98, 99, 103, 153, 157, 187, 200
stone - 90
Dioxin - 46, 193
Discoloration - 204
Divider - 51, 52
strip - 86, 133
Dome - 9, 83, 87
Drapery - 147, 149, 163, 164, 223
Drywall - 71, 72, 74, 75
Duct - 52
Dyeing
carpet - 155
leather - 151
textile - 145, 147, 148
Dye-lot number - 80

E

Earthenware - 128, 130
Eco-labels - 62, 63, 64
Ecosystem - 55, 63, 178
Elasticity - 15, 70, 142, 193, 194
Elastomer - 186
Electroplating - 173, 181
Embodied energy - 55, 58, 61, 226
brick - 88
stone - 90
wood - 97
engineered wood - 116
glass - 122
ceramic - 129
steel - 175
aluminum - 178
plastic - 184
PVC - 191
Embossing - 80, 123, 133, 150, 151, 152, 181, 191
Enamel - 173
Endocrine disruptor - 44, 77
Energy Star - 63
Engineered
stone - 92, 204
veneer - 108, 113, 114
wood - 34, 45, 96, 115, 116, 118
Environmental Movement - 54
Environmental impact
aluminum - 178
ceramic - 129
concrete - 83
leather - 150
plastics - 184
stone - 90
wood - 97
Environmental Protection Agency, EPA - 41, 44, 62, 63
Epoxy - 195, 196
resin - 45, 183, 202
Estimation - 211, 212, 213
Ethylene-vinyl acetate, EVA - 124
Exotic woods - 97, 101, 107, 113
Extrusion
metal - 175
plastic - 198
Expansion joint - 17, 84, 85, 86, 133

F

Fabric - 136, 137, 138, 139
construction - 148, 149
weight - 147
Fading - 78, 98, 103, 122, 149
Faux finish - 76
Faux leather - 191
Felt - 136, 145, 155
Ferrous Metals - 173, 174
Fiber
filament - 138, 139, 140, 148, 152
natural - 139, 140, 141
staple - 138, 139, 141
synthetic - 141, 142, 143
Fiberglass - 72, 74, 93, 201

Fieldstone - 92
Figuring - 98, 105
Fire safety - 35, 36, 37
Fire-rated - 124
Fire resistance - 35, 36, 46, 68, 72, 143, 173, 184
Flame retardant - 37, 46, 62, 146
Flagstone - 92
Flanking - 51, 52, 225
Flash coving - 189, 190
Flax - 139, 140, 191
Flitch - 113
Float glass - 58, 121, 122, 123, 125
Floating
screed - 84
slat - 48
Flocked wallpaper - 77
Fly Ash - 15, 59, 82
Foam
aluminum - 14, 179
glass - 123
polyurethane, PU - 37, 46, 160, 186, 195
Foil - 170, 173
Foil-backed gypsum board - 72
Forest Stewardship Council, FSC - 97
Formaldehyde - 11, 45, 62, 115, 196, 197, 204, 222
Fossil fuel - 55, 56
Frieze - 154
Frit - 126, 173
Frost resistance - 87
Frosted glass - 126
Fungal - 78, 98, 99, 134
Furniture - 37, 46, 109, 112, 116, 160, 161, 162, 208
frame - 162
upholstered - 34, 37, 160, 162
Furring - 52

G

Genetically modified - 56, 187
Gilding - 180
Glass - 9, 10, 12, 58, 121, 122, 123, 124, 125, 126, 127, 128
Glass fiber reinforced
concrete - 86
plaster - 74
plastic - 182, 193
Glaze - 128, 130, 131
Glazing - 9, 35, 121, 123, 127, 128
Gothic - 10
Grain - 14, 15, 30, 75, 85, 98, 99, 101
open - 101, 106, 111
tight - 101, 104
Grasscloth - 77, 79
Greige goods - 146
Green Building Certification - 56, 61
Greenhouse effect - 122
Greenhouse gas - 55, 57, 62, 141
Greenwashing - 63
Grout - 16, 94, 95, 130, 131, 133, 134
Growth rings - 98, 99
Gum Arabic - 68, 69
Gypsum - 50, 71, 72, 73, 81

H

Hand - 144
Handrail - 19, 35
Hardwood - 97,
Hardboard - 118
Heartwood - 98, 103, 104, 105, 106, 107, 109
Heating, ventilation, air-conditioning, HVAC - 42, 63
Hemp - 49, 140
High density polyethylene, HDPE - 182, 189, 198
High efficiency particulate air filter, HEPA filter - 42
High-pressure laminate, HPL - 205
Hickory - 102, 104, 105
Hide - 150, 151
Honeycomb - 179, 201
Honing - 94, 172
Humidity - 16, 45, 72, 84, 98, 109, 140
Hygroscopic - 98, 140
Hypoallergenic - 139, 140, 197

I

Igneous – 91, 92
Impact insulation class, IIC – 51
Impact resistance – 72, 102, 123, 124, 128, 193, 205
Indoor air quality, IAQ – 41
Insect
 attack – 140
 resistance – 142
Insulation – 15, 49, 57, 83, 84, 121, 149, 163, 189, 192, 195, 201
International Building Code, IBC – 33, 38
International Code Council, ICC – 33
International Green Construction Code, IgCC – 61
Iron – 10, 125, 174, 175

J

Jabot – 164
Jacquard loom – 144, 145
Janka hardness rating – 101
Joint compound – 73, 75
Jute – 140

K

Kerfing – 72, 109, 118, 203
Kiln drying – 108
Knitting – 144, 145
Knot – 14, 75, 101, 102, 106, 107

L

Lacquer – 111, 112, 115
Laminate – 45, 115, 117, 196, 204, 205, 228,
Latex – 10, 52, 70, 133, 192
Lath – 73, 74, 133
Lathe – 170
Life-cycle assessment, LCA – 55, 156
Lead – 44, 62, 77, 121, 129, 180, 222
Leadership in Energy and Env. Design, LEED – 61, 62, 63, 64, 65, 225
Leather – 149, 150, 151, 152, 190, 191, 202
Limestone – 9, 82, 83, 91, 94, 123
Linen – 37, 140, 147, 162
Liner – 78, 81
Linoleum – 22, 56, 191, 192, 202
Linseed oil – 118, 191
Local materials – 55
Loom – 10, 144, 145, 155
Lucite – 183, 187
Lumber – 96, 99, 100, 102, 107, 108, 110
Luster – 22, 23, 138, 139, 145, 166, 167

M

Magnesium – 167, 178, 180
Magnetism – 80, 173, 178
Mahogany – 8, 104, 106, 107, 110
Maple – 104, 111
Marble – 8, 15, 24, 86, 90, 92
Martindale abrasion test – 147, 219
Masonry – 87, 94, 95
Medium density fiberboard, MDF – 15, 115, 116, 117, 118, 222
Melamine – 11, 45, 115, 196, 197
Membrane – 86, 133
Mercerizing – 138, 145
Metal – 166, 167, 168, 169
 casting – 169, 174, 179
 corrugated – 176, 177, 201
 plating – 173, 180, 181
Metallic – 167, 181,
Metalloid – 167
Metamorphic – 91, 91, 204
Methane – 57, 141, 194
Methenamine pill test – 36
Microfiber – 138, 143
Microplastics – 59, 184, 185
Mildew – 19, 42, 68, 72, 78, 130, 140, 192
Mineral – 23, 82, 90, 92, 139, 141
Mineral streak – 102, 106
Mirror – 121, 122, 125

Miter – 109
Mohair – 141
Moisture – 15, 16, 17
 absorption – 83, 142
 exposure – 15, 72, 73, 84, 130, 132, 148, 224
 resistance – 44, 88, 116, 146
 resistant – 72, 110, 205
Mold – 16, 19, 42, 43
 resistant – 72
Molding – 11, 13,
 blow – 193, 197, 199
 ceramic – 128
 compression – 199
 injection – 13, 197, 198, 199
 over – 199
 rotation – 199, 200
 metal – 174

Moldability – 74, 184, 186
Moldavite – 10, 121
Monomer – 182, 192, 197
Mortar – 86, 87, 89, 95, 132, 133
Mullion – 127
Murano – 121
Mylar – 79, 193

N

National Sanitation Foundation, NSF International – 34, 156, 175, 203
Natural – 10, 16, 27, 71
 fiber – 139, 140, 141, 142
 resource – 54
 rubber – 11, 194
 stone – 90, 91, 92, 93, 95, 203
Nickel – 125, 174, 181
Nickel-sulfide accumulation – 123, 124
Noise reduction coefficient, NRC – 49, 50, 79
Non-ferrous metals – 178
Non-vitreous – 131
Nominal – 100
Nylon – 186, 192
 carpet – 152, 153
 fiber – 142

O

Oak – 97, 101, 102, 103, 104, 108, 111, 116
Occupancy type – 33, 35, 222
Off-gassing – 42, 55, 223
Oil – 184, 185
Olefin
 fiber – 142
 polyolefin – 188, 189
Onyx – 91, 92
Osnaburg – 79
Oxide – 125, 168, 173, 178, 180
Ozone – 122

P

Paint – 66, 67, 68, 70
 application – 68, 69, 74, 75, 214
 disposal – 76
Paneling – 8, 20, 48, 102, 112, 178
Paper – 71, 79, 204, 205
Particleboard – 45, 115, 117, 204
Partition – 51, 52
Passive house standard – 57, 58
Patina – 16, 17, 101, 150, 168, 169, 179, 181
Pattern matching – 80, 93, 94, 114, 161
Paver – 123, 130
Penetrating sealers – 95
Perforation – 49, 150, 179
Petrochemicals – 182
Phenolic – 45, 113, 115, 196
Pigment – 8, 26, 66, 67, 68, 71, 85, 145, 183, 191
Pile – 38, 41, 153, 154, 159, 224
Pilkington – 121
Pill test – 36, 37
Pilling – 140, 142, 145, 148
Pine – 100, 107, 111

Phthalate - 45, 46, 62, 185, 193
 Pietra dura - 90
 Pitting - 168, 175
 Plaster - 71, 73, 74
 board - 71
 of Paris - 73
 Plastic laminate - 45, 114, 115, 117, 204, 205
 Plasticizers - 85, 183, 184, 185
 Plexiglas - 182, 183, 187
 Plywood - 45, 105, 114, 116, 196, 203
 Polyamide, PA - 142, 143, 192, 193
 Polycarbonate, PC - 45, 124, 187, 188
 Polyepoxide - 195
 Polyester, PE - 143, 193, 203
 Polyethylene terephthalate, PET - 59, 193, 194
 Polyisoprene - 194
 Polylactic acid, PLA - 56, 187
 Polymerization - 45, 46, 184
 Polymethyl methacrylate, PMMA - 143, 187, 188
 Polyolefin - 184, 188, 189
 Polypropylene, PP - 142, 184, 188, 200
 Polystyrene, PS - 192
 Polyurethane, PU - 46, 95, 99, 112, 150, 160, 177, 186, 195
 Polyvinyl chloride, PVC - 46, 143, 189
 Porcelain - 128, 129, 130, 131, 132
 Porcelain Enamel Institute, PEI - 131
 Portland cement - 73, 82, 83
 Pottery - 9, 128
 Powder coating - 16, 147, 173
 Pozzolana - 82
 Precautionary List - 64
 Prefinished - 72
 Pre-weathered - 17, 169, 181, 219
 Primer - 75, 81
 Printing
 3d - 129, 200
 textile - 146,
 wallcovering - 79, 80

Q

Quarry - 55, 90, 91
 Quarrying - 71, 83, 90, 91
 Quarry tile - 130
 Quartz - 45, 92, 120, 203, 204
 Quartzite - 204
 Quenching - 169

R

Radiant panel test - 36,
 Railing - 30, 124
 Railroaded application - 161
 Rammed earth - 88
 Rapidly renewable - 56, 102, 140, 141, 149, 226
 Rawhide - 150, 151
 Rayon - 142, 143, 183
 Reclaimed - 56, 60, 62
 wood - 60, 108
 brick - 88
 Reconstituted veneer - 113, 114
 Recycling - 58, 59, 60, 61, 225, 227
 aluminum - 178
 carpet - 155, 157
 glass - 122
 gypsum - 71
 leather - 150
 metal - 167
 paint - 76
 plastic - 184, 185, 186
 PVC - 191
 textile - 137
 thermosets - 195
 Red List - 62, 63, 64, 222
 Red oak - 35, 104
 Reflection
 acoustic - 47, 48, 49, 50
 acrylic - 187
 glass - 125, 126
 light - 19, 22, 23, 95
 metal - 172

Regulations - 4, 33, 47, 137, 151, 223
 Reinforced concrete - 14, 51, 83, 86, 176
 Relief - 27, 47, 80, 118, 131,
 Renovation - 44, 61
 Resiliency - 127, 139, 190, 202, 219
 Resilient
 finish - 51
 flooring - 36, 188, 189, 202
 Resin - 183, 185, 186, 198, 199
 Resin identification code, RIC - 185, 186
 Retting - 139
 Re-upholstery - 162
 Reuse - 55, 64, 226, 227
 Reverberation - 19, 48, 224
 Riveting - 171
 Room corner test - 36
 Rubber - 186, 194, 195, 202, 203
 Run-right application - 161
 Running bond - 88
 Rug - 101, 156
 Rust - 108, 177
 Rustic - 102

S

Safety glass - 124
 Sandblasting - 23, 75, 94, 126,
 Sandstone - 91, 94
 Sapwood - 98, 102, 103, 104, 105, 106, 107, 109, 112, 113
 Satin
 metal finish - 172
 laminate - 204
 sheen - 69
 weave - 144
 Scrim - 79
 Sealant - 98,
 Sealer - 78, 79
 glass - 127, 128
 grout - 134
 topical - 95
 penetrating - 95
 Seam slippage - 144, 148
 Security
 film - 193
 glass - 124, 125, 188
 Sedimentary - 91, 94
 Selvage - 148
 Semi-vitreous - 131
 Shade - 163
 Shading coefficient - 162
 Sheen - 23, 69, 73, 111, 112, 204
 Sheep - 140, 141, 149
 Shellac - 111, 112
 Shelving - 60
 Shop drawings - 210
 Shop-sawn veneer - 113
 Shrinkage - 106, 145, 146
 Shutter - 162, 163
 Sidelight - 73
 Silica - 10, 67, 82, 123, 128, 197
 Silicone - 95, 127, 186, 187, 194, 197
 Silk - 138, 139, 140, 141
 Silkworm - 140, 141
 Silver - 15, 125, 169, 180, 181,
 fiber - 143
 Sink - 64, 76, 176, 184, 203
 Sizing - 81
 Skim coating - 73, 74, 75
 Skylight - 188
 Slate - 92
 Slip resistance - 38, 85, 94, 132, 156, 194, 210, 224
 Smolder resistance - 37
 Soda ash - 123
 Softwood - 97, 107, 116, 117,
 Soiling - 154, 202, 227
 Solid surface - 45, 203, 204, 223
 Solid wood - 96, 97, 98, 99, 100, 102
 Solution dyeing - 145
 Sound
 attenuation - 50, 52, 124
 absorption - 48, 49, 50, 155, 163, 164

transmission – 50, 51, 124
Sound transmission coefficient, STC – 48, 52, 224, 225
Specification – 208, 209, 210, 216
Speech intelligibility – 48, 52, 224, 225
Speech privacy – 52, 225
Springs – 161
Sprinkler – 35, 36, 222
Stain resistance – 78, 79, 87, 145, 146
Stained glass – 10, 121
Stairs – 86, 124, 132, 157
Standards – 16, 32, 34,
Steel – 11, 12, 167, 168, 174, 175, 176, 177, 180, 181, 201
 stainless – 16, 167, 168, 172, 175, 176, 180
Steiner tunnel test – 35
Stitches per inch – 148, 154
Stoneware – 128, 130
Stucco – 73
Styrofoam – 192
Subfloor – 84, 86, 95, 102, 116, 132
Suede – 150
Suspended ceiling – 52
Sustainable
 design – 54, 55
 thinking – 12, 20, 60

T

Tack strip – 157
Tanning – 149, 150, 151, 180
Teak – 16, 102, 107
Teflon – 182
Tempering
 glass – 123, 128
 metal – 169
Tension – 13, 14
Tensile force – 120, 200
Terracotta – 130
Terrazzo – 16, 86, 87
Tesserae – 121
Tex – 138
Texture – 20, 21, 22, 27, 28, 29, 47, 68, 104, 105, 144,
Thermal
 bridge – 30, 43, 78, 223
 comfort – 62
 expansion – 133, 176
 insulation – 15, 43, 49, 149
Thermoplastic – 186, 197, 198, 200
Thermoset – 11, 186, 194, 195, 197
Thickset installation – 95, 133
Thinset installation – 95, 133
Third-party
 testing – 34
 verification – 64
Tile Council of North America, TNCA – 34, 131, 132, 133
Tile
 carpet – 49, 60, 155, 156, 158
 leather – 152
Timber – 12, 107, 160
 cross-laminated, CLT – 97, 117
Tin – 167, 179, 181
Titanium – 167, 170, 180, 181
Topcoat – 42, 71, 75, 101, 111, 152, 176
Toxicity – 35, 41, 45, 55, 68, 70, 178, 185
Travertine – 20, 91, 92, 95, 204, 219
Trim – 35, 41, 70, 74, 102, 117,
Trim strip – 159
Tufted – 153, 154
Twill weave – 144
Twist pile – 154
Twisting – 137, 138, 139, 143
Type-X gypsum board – 72

U

Urea-formaldehyde – 45, 117, 196, 197
Underlayment – 51, 102, 116, 118, 155
Underwriters Laboratories, UL – 34, 35, 36, 63
Universal design – 37, 39, 224
Upholstery – 160, 161, 162
Ultraviolet – 120, 122
UV resistance – 140, 142, 143, 164, 184, 187, 219

V

Valance – 164
Vapor barrier – 132
Varnish – 16, 111, 112
Velvet – 19, 78
Veneer
 reconstituted – 113, 114
 stone – 95
 wood – 98, 77, 112, 113, 114, 115
Vertical ignition test – 37
Vinyl –
 asbestos tile, VAT – 191
 composition tile, VCT – 189, 190
Vitreous – 128, 131
Volatile organic compounds, VOC – 42, 45, 56, 63, 64, 210, 223
 carpet – 156, 157, 158
 paint – 68, 70
 plastic – 196, 197
 wood – 110, 112, 115

W

Wallboard – 73
Wallcovering – 73, 77, 78, 79, 80, 81
Wallpaper – 27, 28, 44, 77, 80, 213, 214, 215
Walnut – 103, 106, 110
Warp – 144
Warping – 17, 99, 106, 108, 109, 115, 219
Water resistance – 72, 112, 116, 130, 132, 197
Wax – 101, 111, 112
Weave – 144, 148
 carpet – 152, 153
Webbing – 160, 161
Wert – 144
Welding
 metal – 170, 171, 172
 plastic – 190, 200
Wheelchair – 37, 39, 219
Wilton weave – 153
Window treatment – 37, 137, 162, 163, 165, 208, 218
Wire mesh – 74, 123
Wood finish – 111
Wood flooring – 51, 101, 104, 110, 227
Wool – 19, 56
 fiber – 140, 141, 142, 152, 153
Woven – 136, 137, 144, 145
Wrought iron – 174
Wyzenbeek abrasion test – 147, 219

Y

Yarn – 138, 139, 145, 148, 152, 153, 154

Z

Zinc – 167, 168, 176, 181